

HAVING FUN WITH TRAINS

NOVEMBER 2021 | FREE

# MRH

MODEL RAILROAD HOBBYIST

**ALSO:**

- Stopping blocks in staging
- Military model load examples
- Weathering tar paper roofs
- Modeling pine/fir trees
- ... *and more inside!*

**Nick Campbell does ...**

## Extreme weathering of this covered hopper

**▶ READ NOW**



**ADAPTIVE EDITION**

*Landscape or Portrait depending on screen size*



**DOWNLOAD**

**TABLE OF CONTENTS**

# This is the screen-adaptive PDF version of MRH magazine

*This PDF will try to fill the screen. If the screen is wide enough, it displays two facing pages (emulating the old landscape format), otherwise it displays one page in portrait.*

*On mobile devices, if you change your device orientation, the PDF adapts to fill the screen with either a portrait or a landscape view as appropriate.*

## **WORKS BEST WITH ...**

- Windows: open with Acrobat or Firefox
- Mac: open with Preview, Acrobat, or Firefox
- Linux: open with Acrobat or Firefox
- Apple iPad or iPhone: open with SideBooks app (free)
- Android tablet or phone - open with SideBooks app (free)

*If you're not seeing the PDF adapt, then your PDF viewer lacks the adaptive display feature. Please use one of the recommended free PDF viewing apps listed above to get the screen adaptive behavior. Or try the Wide Edition instead.*

# Now Available From

## ATLAS MASTER® N 53' EVANS DOUBLE PLUG DOOR BOX CAR



Chicago &amp; North Western



Grand Trunk



Van Brode Milling



Illinois Central



British Columbia Railway



Astoria Plywood



Boise Cascade



Conrail

### FEATURES:

- 70-TON ROLLER-BEARING TRUCKS
- READY-TO-RUN
- ROOF OVERSPRAY
- ACCUMATE® COUPLERS

ACCUMATE® COUPLERS ARE MADE UNDER LICENSE  
FROM ACCURAIL, INC.

## DON'T MISS OUT!

**CLICK HERE!**

FOR MORE INFORMATION OR TO LOCATE A DEALER, PLEASE VISIT [WWW.ATLASRR.COM](http://WWW.ATLASRR.COM).  
ATLAS MODEL RAILROAD CO., INC. • 378 Florence Ave., Hillside, NJ 07205



REGISTER  
(free)

INDEX

TABLE OF CONTENTS

# STAFF

HAVING FUN WITH TRAINS

**MRH**  
MODEL RAILROAD HOBBYIST

Model Railroad Hobbyist | November 2021 | #141

## Editorial Staff



Joe D. Fugate, Publisher and Editor



James Regier, Assistant Editor



Patty Fugate, Pasteup and Layout



Richard Bale, News and events



Jeff Shultz, News and events, Tech Assistant



Mike Dodd, Copy Editing



**RATE THIS ISSUE**

ISSN 2152-7423

## Advertising

Les Halmos, Account Manager

Jean-François Delisle, Marketing Assistant

## Regular contributors

Eric Hansmann, Contributing editor

Jim Six, Limited Modeler column

Ken Patterson, Reporter-at-Large

## Rotating Columnists

Jack Burgess, Getting Real column

Marty McGuirk, Getting Real column

Nick Muff, Getting Real column

Mike Rose, Getting Real column

Tony Thompson, Getting Real column

Rob Clark, Imagineering

Dave Meek, Imagineering

Ray Dunakin, Imagineering

Published for the glory of God. [What's this?](#)



# MRH SPONSORS



Model Railroad Hobbyist | November 2021

## A - L



[acculites.com](http://acculites.com)



[railroadhobbyshow.com](http://railroadhobbyshow.com)



[archertransfers.com](http://archertransfers.com)

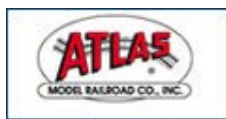

[www.atlasrr.com](http://www.atlasrr.com)



[bachmanntrains.com](http://bachmanntrains.com)

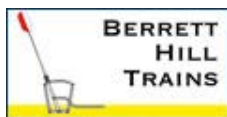

[berretthill.com/trains](http://berretthill.com/trains)



[blairline.com](http://blairline.com)



[coffmaneng.com](http://coffmaneng.com)



[deluxematerials.co.uk](http://deluxematerials.co.uk)



[www.digitrax.com](http://www.digitrax.com)



[dwarvin.com](http://dwarvin.com)



[esu.eu/en](http://esu.eu/en)



[handiaidtrack.com](http://handiaidtrack.com)



[ghbintl.com](http://ghbintl.com)



[iascaled.com](http://iascaled.com)



[krmodels.ca](http://krmodels.ca)



[litchfieldstation.com](http://litchfieldstation.com)

[Vendors: Get your clickable logo on these pages ...](#)



REGISTER  
(free)

[INDEX](#)

[TABLE OF CONTENTS](#)

# MRH SPONSORS | 2

## M - Z



[mapleleaftrains.com](http://mapleleaftrains.com)



[micro-trains.com](http://micro-trains.com)



[store.mrhmag.com](http://store.mrhmag.com)



[www.modelrectifier.com](http://www.modelrectifier.com)



[handlaidtrack.com/mt-albert-scale-lumber](http://handlaidtrack.com/mt-albert-scale-lumber)



[ncedcc.com](http://ncedcc.com)



[www.pwrs.ca/main.php](http://www.pwrs.ca/main.php)



[rapidotrains.com](http://rapidotrains.com)



[ringengineering.com](http://ringengineering.com)



[roometteslighting.com](http://roometteslighting.com)



[scaletrains.com](http://scaletrains.com)



[soundtraxx.com](http://soundtraxx.com)



[sodigi.com](http://sodigi.com)



[sbs4dcc.com](http://sbs4dcc.com)

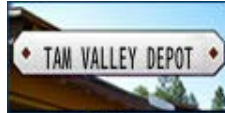

[tamvalleydepot.com](http://tamvalleydepot.com)



[trainfest.com](http://trainfest.com)



[walters.com](http://walters.com)

Looking for something? Check the MRH Marketplace!



Take me there!

# THIS IS OUR IDEA OF THE PERFECT DCC INSTRUCTION MANUAL

GET  
THE  
DETAILS

*Instructions on the  
back of the handheld.*

**Run Loco:** Recall the loco or press Loco and enter #,  $\downarrow$ . **Adjust Speed:** Use knob or press +1 / -1. **F0 - F9:** Press 0 - 9. **F10-28:** Press Shift, then two digits. **Delete Loco:** Press & hold Del. **Stop:** Press Stop. **Turn on/off layout:** Press & hold Stop. **Speed Steps:** Press Spd Step to select 14/28/128,  $\downarrow$ . **Yard mode on/off:** Press Sys, 3. **Accessory:** Press Accy, enter #,  $\downarrow$ . **Press 1 / 2** for on / off. **Route:** Press Route, enter #,  $\downarrow$ . **Fast Clock:** Press Time. **Program on Prog Track:** Press Prog to select Prog Prog Track,  $\downarrow$ . To program following items, enter #,  $\downarrow$ . To skip press  $\downarrow$ . **Adr = Address, SV = Start Voltage, Acc = Accelerate, dEc = Decelerate, TV = Top Voltage, CV #** prompt for CV. Enter CV #,  $\downarrow$ .

Then CV data,  $\downarrow$ . **Program on Main:** Press Prog to select Prog Main,  $\downarrow$ . For Current Loco press  $\downarrow$ , or enter Loco #,  $\downarrow$ . Then same way as above. **Read on Prog Track:** Press Prog to select  $\downarrow$ . To read data press  $\downarrow$ . To skip Shift. **Err = error. Set Consist:** Consist to select SET,  $\downarrow$ . Enter consist # (1-127),  $\downarrow$ . To add loco enter #,  $\downarrow$ . Now use consist # as loco # to run the group. **Clear Consist:** Press Consist to select CLR,  $\downarrow$ . Enter consist #,  $\downarrow$ . **Set Old Consist:** Press Consist to select Old SET,  $\downarrow$ . Enter lead #,  $\downarrow$ . To add loco enter #,  $\downarrow$ . **Run old consist group:** Press Consist, Loco. Enter lead #,  $\downarrow$ . **Clear Old Consist:** Press Consist to select Old CLR,  $\downarrow$ . **Set Cab #:** Press Sys, 6. Enter cab #,  $\downarrow$ . Each cab must have unique #. Cab #1 is master and has following features. **Set last cab allowed to program on Main or Prog track:** Press Sys, 7 or 8 respectively. Enter #,  $\downarrow$ . **Set Route:** Press Sys, 5,  $\downarrow$ . Enter route #,  $\downarrow$ . To add accessory enter #,  $\downarrow$ . **Clear Route:** Press Sys, 0,  $\downarrow$ . Enter route #,  $\downarrow$ . **Set Time:** Press Sys, 1. Enter, time,  $\downarrow$ . **Set Rate:** Push Sys, 2. Enter rate (how many seconds for a minute),  $\downarrow$ . **Select AM, PM, or Military Time:** Press Sys, 4.

Made in China

**MRC** 

**M O D E L R E C T I F I E R C O R P O R A T I O N**

360 Main Street, Suite 2, Matawan, NJ 07747 • Phone: 732-225-2100 • [www.modelrectifier.com](http://www.modelrectifier.com)

FOUNDED BY ROY C. GELBER

■ Train Controls ■ Model Railroad Accessories ■ Plastic Model Kits ■ Scenery ■ Educational Kits



REGISTER  
(free)

INDEX

TABLE OF CONTENTS



**Publisher's Musings: *Locomotives* book update, ...**  
*JOE FUGATE*



**MRH Website this month: Modern farmer figures, ...**  
*Compiled by JOE FUGATE*



**What's Neat: Raddison McGuire's military models**  
*KEN PATTERSON*



**Automatic staging stopping blocks**  
*GREG CIURPITA*



**Extreme weathering a Tangent hopper**  
*NICK CAMPBELL*



**Modeling tar paper roofs**  
*GREG BAKER*



**Savvy Modeler online: Fir/Pine tree modeling**  
*Compiled by the MRH STAFF*



**November 2021 news and events**  
*RICHARD BALE and JEFF SHULTZ*



## NEW ROADNAMES AND ROAD NUMBERS



N de M SD40-2



CSX SD40-3



SANTA FE Snoot

# REBUILT SD40-2s



ARRIVING NOVEMBER 2021



PREORDER NOW

**SCALE**  
 TRAINS

WWW.SCALETRAINS.COM/ROADTRIP  
 ScaleTrains • 7598 Highway 411 Benton, TN 37307  
 844-9TRAINS 844-987-2467 • International 423-299-3689



© 2021 ScaleTrains.com,  
 Inc. ScaleTrains Road  
 Trip, and respective  
 logos are trademarks of  
 ScaleTrains, Inc.

PREPRODUCTION MODELS SHOWN



REGISTER  
*(free)*

INDEX

TABLE OF CONTENTS



# PUBLISHER'S MUSINGS



Model Railroad Hobbyist | November 2021

JOE FUGATE UPDATE ON THE RUN LIKE A DREAM LOCOMOTIVES BOOK ...



**TWO OF MY THREE *RUN LIKE A DREAM* BOOKS HAVE BEEN RELEASED: *TRACKWORK* AND *ROLLING STOCK*.** Yet to be released: *Locomotives*. Once it's complete, this book should be around 100 pages.

There's been a lot of water under the bridge since I started to write *Locomotives* in early 2020, so it's time for an update on this book's status.

## Put on the back burner in March 2020

I started the *Locomotives* book in late 2019 and released Sneak Peek #2 in early March 2020. At that time, I estimated I had nine months left to go in writing this book.

Then as we all know, the world turned upside down in late March 2020. Due to the uncertainty about the future in those early days of the pandemic, our monthly sales plummeted 75%. In order to keep the lights on at MRH Media, we had to lay off our normal staff of contractors who help us run the business.

My wife Patty and I basically ran everything related to editorial work for several months. Once modelers got used to the new normal with lockdowns, sales started to pick up again.

# PUBLISHER'S MUSINGS | 2

The holiday season for 2020 with the lockdowns still in place had superb sales. All told for 2020, thanks to excellent holiday sales, we ended the year just 1% below our sales for 2019.

Meanwhile, all extra-curricular projects such as the *Locomotives* book got shelved.

Thanks to the sales recovering in 2020, as 2021 dawned, we were able to bring staff back on. Some of the staff had gone on to greener pastures, so we had to hire some new talent, most notably, James Regier, as Assistant Editor.

We also had to rethink TrainMasters TV, as the pool of studio segments dried up and Barry Silverthorn retired. We have spun up the new virtual *Backshop Clinic* segments and as of this month are bringing back *Notch8* as a virtual segment with Bob Fallowfield. By December, we will be bringing back *DCC Decoded* as virtual.

## ADVERTISEMENT

### NEW SERIES! RAILROAD MAGAZINE 'YEARS GONE BY'

Founded in 1906, *Railroad Magazine* was the first, and one of the most popular railroad pulp publications, containing first-hand railroad stories and informative articles. It was published until 1979 when it merged with *Railfan Magazine* to form *Railfan & Railroad*, now owned by White River Productions. This series which starts in March 2022 will consist of 12 uniquely decorated cars to commemorate *Railroad Magazine*.

\$27.95 Each

N Scale renderings shown for representation only.

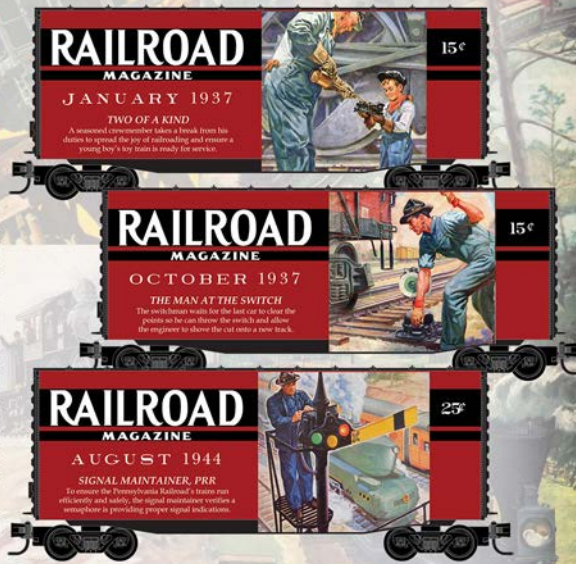

**MICRO-  
TRAINS®  
LINE**

**CLICK HERE FOR MORE INFO**

**N**  
SCALE 1:160

**Z**  
SCALE 1:220



**REGISTER**  
(free)

[INDEX](#)

[TABLE OF CONTENTS](#)

BACHMANN



# TAKE CHARGE

WITH THE LATEST IN HO SCALE PASSENGER POWER

The future of long-distance passenger railroading is heading your way. Bachmann has partnered with Amtrak® and Siemens Mobility to bring you an industry first - our brand new ALC-42 Charger is arriving just as the real units are being delivered from the factory! Based on the highly successful SC-44 Charger, the ALC-42 is designed specifically for cross-country service on America's most scenic and storied routes, displaying an updated appearance with a new nose profile and cab door configuration. Thanks to both Siemens and Amtrak®, Bachmann's ALC-42 has been developed using original design documentation and employs prototype field recordings for maximum realism. Features include a TCS WOWSound® CD-quality 16-bit 44,100Hz decoder with Audio Assist® for easy configuration without CVs, and a Keep-Alive® device for uninterrupted operation, even over dirty track. The WOWSound® diesel-electric locomotive package includes an authentic horn, bell, prime mover, startup/shutdown, compressor, cooling fan, coupler close/release, brake release/application, crew alert, grade crossing quill, station announcements, and more. Take charge of your long-distance passenger operations; bring the Amtrak® ALC-42 to your HO scale railroad.



AMTRAK® #300  
(Phase VI)  
Item No. 68301



AMTRAK® #305  
(Phase VI)  
Item No. 68302



AMTRAK® #301 - 50th Anniversary "Day 1"  
Item No. 68303

HO  
SCALE

OFFICIAL  
LICENSEE  
of  
AMTRAK®

#### Features include:

- Siemens-approved design
- DCC sound-equipped for sound, speed, direction, and lighting control
- TCS true CD-quality audio in 16-bit, 44,100Hz sound
- Keep-Alive® device that keeps your engine running during power interruptions due to dirty track or loss of electrical contact
- dual-mode NMRA compliant decoder
- voice-guided Audio Assist® programming tool for easy setup of almost all decoder functionality
- directional headlights and marker lights
- interior corridor work lights
- steady/alternate flashing ditch lights
- die-cast frame with separately applied windshield wipers, grab irons, and detail parts
- E-Z Mate® Mark II couplers

Click to  
learn more

WOWSound®

Shipping December • MSRP: \$469.00 each

Bachmann Industries, Inc. • 1400 East Erie Avenue • Philadelphia, PA 19124 USA • [www.bachmanntrains.com](http://www.bachmanntrains.com)

Click for more information.



[MRHMAG.COM](http://MRHMAG.COM)

[INDEX](#)

[TABLE OF CONTENTS](#)





# Introducing THE LUMBER STORE



## ROTATING STORAGE RACK

On its own, or fully loaded with Mt. Albert Scale Lumber!

[handlaidtrack.com](http://handlaidtrack.com)

1-888-252-3895

## PUBLISHER'S MUSINGS | 3

### Moving the *Locomotives* book to the front burner

Now that the new help has been trained and becoming efficient and now that we've got a full complement of TrainMasters segments coming back online, I can bring the *Locomotives* book back to the front burner!

Sneak Peek #2 had 34 pages in it, so the book is roughly 30% done.

My first task was to convert the book from InDesign to Affinity Publisher, our new pasteup app. That's now *done*.

Next, I need to produce Sneak peek #3. I'd like to push toward 40 pages for this next sneak peek, adding another 10% to the total book that's written.

I'm hoping to get Sneak Peek #3 out by late January. I'm focusing mainly on chapter 2, "Testing, break-in, and lubrication."



REGISTER  
(free)

[INDEX](#)

[TABLE OF CONTENTS](#)

It's more than a hobby.  
It's our passion.



Model railroading is our lifelong pursuit for signature scenes and meticulous detail. For just shy of 90 years, Walther's has cultivated our craftsmanship and sparked our imaginations with everything needed to build our dream layouts. Becoming a Yardmaster rewards us with everyday special pricing and priority on the new products we love. That's why we're Walther's Yardmasters. Join us. Visit [Walther's.com/yardmasters-club](http://Walther's.com/yardmasters-club) to learn more.

# WALTHERS®

Support your local hobbyshop • visit [walther's.com](http://walther's.com) • call 1-800-4-TRAINS

© 2021 Wm. K. Walther's, Inc.



## So what's in the *Locomotives* book?

This book is volume 3 in the *Make it run like a Dream* series. From the back cover of the *Locomotives* book:

“The *Run like a Dream* series came out of Joe Fugate’s own experiences trying to get his HO Siskiyou Line layout to run as flawlessly as possible.

While trackwork and rolling stock form half the battle of good operation, good performing locomotives forms much of the other half. Excellent performance doesn’t happen by accident, either.

Joe presents many preventive tricks you can apply, plus clever debugging tips for getting to the bottom of a problem quickly.

And finally, regular maintenance done right keeps things running well. Achieving and maintaining excellent performing locomotives is the focus of this book.”

In short, this series collects all the best practices for getting superb performance and puts them under a single cover for trackwork, rolling stock, and locomotives.

The series aims to cover all scales from Z to O, as well as all eras. In the *locomotives* book, I’m covering both steam and diesel locomotives, for instance.

Here are the *Locomotives* book chapters:

1. Realizing the dream: Bulletproof performance
2. Preventive: Break-in, testing, and lubrication
3. Preventive: Electrical pickup
4. DCC and programming
5. Locomotive lighting
6. Locomotive sound
7. Locomotive tuning and maintenance
8. Enhancing locomotive ops realism



Now available in HO scale for the Long Island and Pennsylvania Railroads  
 RTR painted and lettered and detailed  
 for the 1939 New York Worlds Fair  
 3 Road Nos. each for LIRR and PRR  
 Both units motorized and DCC ready  
 and with DCC as an option

DD-1

**21**



**GHB**  
 International

PO Box 4063  
 Gaithersburg, Maryland 20885  
 email: geoghb@erols.com  
 tel: 301-515-0182

**ORDER NOW**



HO SCALE MODERNIZED LIRR/PRR DD-1 ELECTRIC ENGINE



\$499.99 MSRP DCC Ready

\$599.99 MSRP DCC EQUIPPED - ESU LOCKSOUND 5 INSTALLED

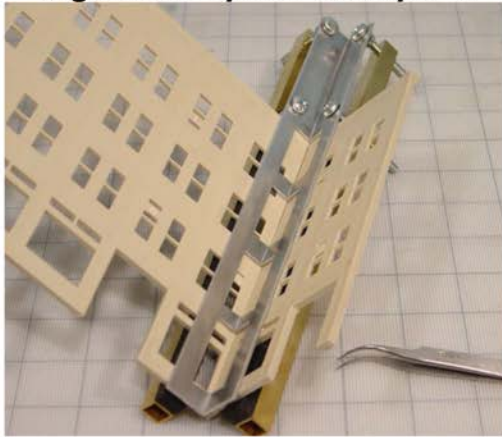
**"Right and Splice Clamps"™**

**Quality Tools with Superior Versatility**

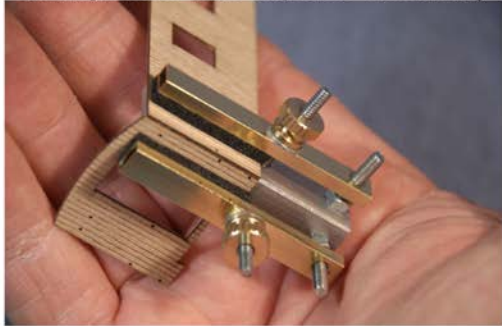

**Essential Tools for Great Modeling**

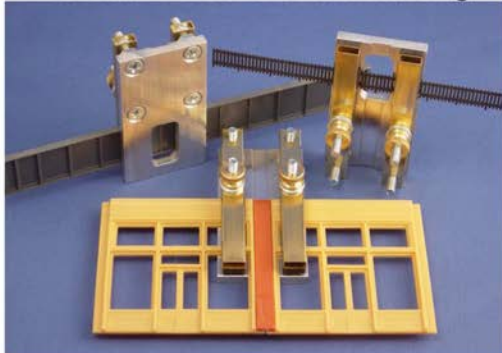

**Coffman Graphic Solutions**

1500 River Circle, Richmond KY 40475

**Click Here**

**Visit our new Website:**

**[www.coffmaneng.com](http://www.coffmaneng.com)**

## How have the first two volumes been received?

Here's what the series customers have said about the first two books:

### Trackwork book reviews ...

"Excellent reference book. Like sitting at the feet of a master sensei and listening to the years of experience.

"You may not agree with all of the work required to achieve the results, but it is clearly a quality-driven approach based on sound trial and error." - *Mike C.*

"Wow! I wish I'd had this before my last layout. I'm in the planning stage for my 3rd. After reading Trackwork I'll have a much better design and smoother running! I can't wait to break ground." - *David W.*

### Rolling Stock book reviews ...

"Excellent guide that is superbly organized and so easy to follow that I wanted to run to the workbench and dive right in.

"I especially liked the concise focus points that brought



**REGISTER**  
(free)

**[INDEX](#)**

**[TABLE OF CONTENTS](#)**





**ORDER BOOK NOW OPEN  
RESERVE YOURS NOW!**

**THE SHAY**



The Shay locomotive was the most widely used geared steam locomotive. The locomotives were built to the patents of Ephraim Shay, who has been credited with the popularization of the concept of a geared steam locomotive. Although the design of Ephraim Shay's early locomotives differed from later ones, there is a clear line of development that joins all Shays. In 1884, they delivered the first 3-cylinder (Class B) Shay.

### **Class B, Lima-built 50-ton 2-truck Shay**

Our rendition of The Shay will feature ESU LokSound V5 sound decoder. Cast Chassis, working external valve gear and drive shafts. Working directional lamps front and rear.

**Limited Production Run  
Reservations now Open**

**DCC Ready \$299**

**DCC Fitted \$339**

**DCC Sound \$449**

**Expected delivery Fall 2022**  
Easy pay 0% installment plan available

**HO scale**

 [www.krmodels.ca](http://www.krmodels.ca)

attention to the small details that are so important in our craft. This book will fast become a hobbyist Bible to one and all! Highly recommended." - *Edward E.*

"I've been a model railroader for quite some time. I have cars that are 30-40 years old on the layout, and have always had issues with derailments. I followed the guidelines in the book and changed out all the old couplers and put metal wheelsets on all the cars. What a difference – my derailments went away! This book was well worth the money." - *Gregory J.*

"Informative. Lots of information and concerns which I and many modelling friends had never thought about. Looking forward to the third volume." - *Wade W. R.*

## **Entire series review ...**

"This series is outstanding, and a classic example of – wish I'd known these things from the beginning!

"If you are relatively new to the hobby, get these pubs right away and use best practices from the beginning.

"If you've been around awhile, you may find yourself wanting some 'do overs' after reading these.

"So far the series has led me to tune up my rolling stock, which had the effect of showing that even some areas of nominally level bench and trackwork were not so level as they appeared. You can tell now because the cars roll away on their own. Combine that with the issue on trackwork, and next thing you know I'm looking at tearing out and laying new.

"What kind of great knowledge will I get from the locomotive book, and what will I start changing based on that? One wonders." - *Kent B.*

"The first two books in the series (Trackwork & Rolling Stock) are outstanding resources. I am certain that Locomotives will be just as good.



**REGISTER**  
(free)

[INDEX](#)

[TABLE OF CONTENTS](#)



# FAST TRACKS

Build your own trackwork easily, quickly, and affordably.



## TRACK BUILDING SYSTEM



## Introducing Diamond Line Crossing Kits



Building an accurate crossing has long been a challenge in our hobby.

### Not anymore with Diamond Line Crossing Kits!

Fast Tracks Diamond Line Crossing Kits make the job of building a good looking, accurate crossing much simpler. Precision cast parts and matching laser cut ties work together to ensure quick construction. Each of the castings are designed to press into the laser cut ties, automatically locating all the parts and electrical isolation gaps. The parts are simply pressed and glued in place.

HO scale 90 degree versions are the first in what will be a large library of popular sizes

**Single**



**Double**



**Quad**

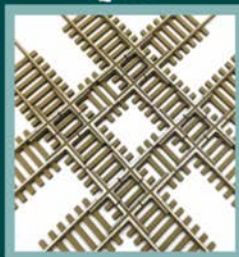

All Fast Tracks track fixtures and tools are NMRA compliant



**Easy Ordering • Fast Delivery • Free Shipping\***  
\*applies to North America only on orders over \$150.00 US

shop online 24/7

handlaidtrack.com

1-888-252-3895

service@fast-tracks.net

# THE TEN WHEELER



# CLICK HERE



[REGISTER](#)  
*(free)*

[INDEX](#)

[TABLE OF CONTENTS](#)

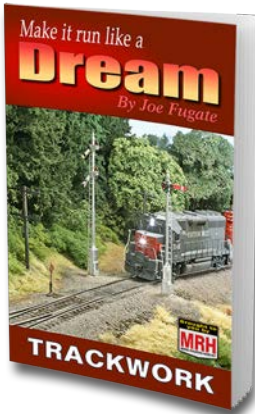

Available NOW!

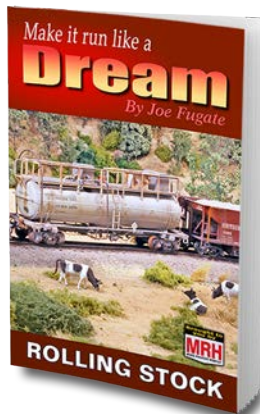

Available NOW!

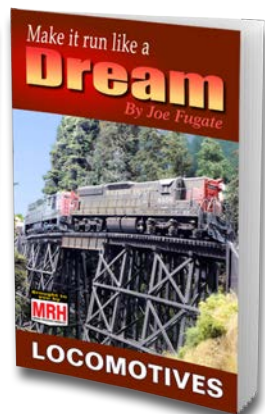

Est release: Summer 2022

[Learn more on the MRH Store →](#)

"I have an operations-oriented N Scale layout and suffer the usual derailments when pushing cars into tight spurs or over crossovers. While I have not yet got my layout 'Running Like a Dream,' I feel like I now have a fighting chance. This series, especially in conjunction with the other *MRH* resources like 'Running Extra' and TMTV should help any serious modeler achieve success. Highly Recommended." - *William F.*

## Final thoughts

I am pleased to see this book series is helping others realize the dream of a great-running layout. I know I would have given my eye teeth to have these books *when I started the hobby.*

Here's hoping the *Locomotives* book will top off the series – finally delivering the most comprehensive collection of hobby performance best practices anywhere. Let's make the dream come true!



**RATE THIS ARTICLE**





# Every little bit helps!

Registered MRH readers  
get **another** 10% off with  
the coupon code here:



**Unwrap my  
coupon code now!**

[click here](#)

That's right, on top of our  
holiday discounts, use this  
coupon code to get **ANOTHER**  
10% off the holiday sale price!



Happy  
Holidays!



**TMTV sale offers**

[click here](#)

Model  
Railroad  
Hobbyist  
Store

**MRH Store sale offers**

[click here](#)



**REGISTER**  
(free)

[INDEX](#)

[TABLE OF CONTENTS](#)



## LAST ISSUE RATINGS

Top rated articles in the [October 2021 issue](#) of *MRH* are:

- 4.8 October 2021 news
- 4.6 24 sq ft of layout fun
- 4.4 Make your own Jersey Barriers

Issue overall: 4.9

Top rated articles in the [October 2021 issue](#) of *Running Extra ...*

- 4.8 Getting Real: Scratchbuilding three cabooses
- 4.6 Building a tower with 3D printing
- 4.3 Ah-hah Moment: New source for low temp solder

Issue overall: 4.0

**Rate the articles!** Click the comments button on each article and select the star rating you think it deserves. ■

Get the latest Model Railroading News, Tips, Reviews & Opinions

**CHECK  
IT OUT!**



**Our iTunes feed has changed search for  
"Crew Call with Mike Rose" to receive the latest episodes!**

**[www.themodelrailroadpodcast.com](http://www.themodelrailroadpodcast.com)**

Host:  
Mike Rose: [www.mrhobby.com](http://www.mrhobby.com)

**Don't Miss our Monthly Interviews  
& Product Announcements**



## TABLE OF CONTENTS | RUNNING EXTRA

November 2021



**Publisher's Welcome: Locating tiny non-magnetic screws**

JOE FUGATE



**Limited Modeler: Narrowing your layout scope**

JIM SIX



**Getting Real: Modeling the Kansas City passenger facilities**

NICK MUFF



**Scratchbuild a backwoods lumber mill**

PETER ELSEA



**Camas Prairie First Subdivision modular layout**

TIMOTHY DUDLEY



**In praise of dabbling**

DON VAIL



**Ah-Hah Moment: Better paint brushes for detail work**

JOE FUGATE

In



# RUNNING EXTRA

## In November ...

**Buy November eBook - \$2.99**

104 pages

[store.mrhmag.com](http://store.mrhmag.com)



**REGISTER**  
(free)

[INDEX](#)

[TABLE OF CONTENTS](#)

Best of the

MRH WEBSITE

Website

MRH  
mrhmag.com

THIS  
MONTH

Model Railroad Hobbyist | November 2021

Compiled by **JOE FUGATE**



## Finding modern farmer figures

*MRH* forum member **NevinW** (Nevin Wilson) asked about where to find some modern farmer figures for his layout.

The *MRH* forum members rallied to the cause and have posted sources of many figures that could work as modern farmers in a pinch. The figures may not be specifically farmers, but they certainly can be repurposed as farmers!



[View the full thread on the MRH website](#)

▶ **MRH'S MONTHLY GREAT MODELER POSTS**



1. Chris vanderHeide has regular blog thread documenting how he's making the structures for his Algoma Central Railway.

## Structures for the Algoma Central Railway

MRH forum member **cv\_acr** (Chris vanderHeide) has been blogging about how he's making the structures for his Algoma Central Railway layout:

*“Modeling a prototype line means most or all of the structures will be either kitbashed or customized. Particularly when you're modeling a smaller and more remote regional railway, so ‘Canadian Pacific Standard no. 3 Station’ doesn't really fit the bill.*

*“My road of choice is the Algoma Central Railway, a Canadian regional railway in northern Ontario. This thread documents structure builds my railway specific structures.”*

Chris' structure thread shows some great solutions to his structure needs, so follow along for some inspiring insights!

[View the full thread on the MRH website](#)



[REGISTER](#)  
*(free)*

[INDEX](#)

[TABLE OF CONTENTS](#)



**WOW!**

# NSC 5092

NATIONAL STEEL CAR 5092 CU FT  
COMBO DOOR BOX CARS



ACTUAL  
PROTOTYPE  
BEFORE PAINTING



The Pacific Great Eastern/British Columbia Railway received 1,785 of these boxcars from National Steel Car between 1971 and 1974, making them more numerous than any boxcar on the railway. They were seen all across Canada and the United States in lumber service. From 1989 they were rebuilt for pulp service and many have continued in service with CN.

**CLICK  
HERE  
FOR HO  
SCALE**

**CLICK  
HERE  
FOR N  
SCALE**

- 4 Styles of sliding doors, Youngstown & 3 rebuilt doors
- Doors with & without fork pockets
- 3 Different door stops (Small, Large & Large Modified)
- 70-ton Barber S-2 trucks & 100-ton trucks with modified bolsters.
- 2 Ends, riveted & non-riveted between corrugations
- Vented ends & non vented ends
- Vented sides & non vented Sides (Arched top & Wedge)
- 2 Different side sills (Notched & Straight)



## NORTH AMERICAN RAILCAR CORPORATION

**PRE-ORDERS WERE ALREADY TAKEN BUT WE  
HAVE A LIMITED AMOUNT LEFT FOR THE SHELF**



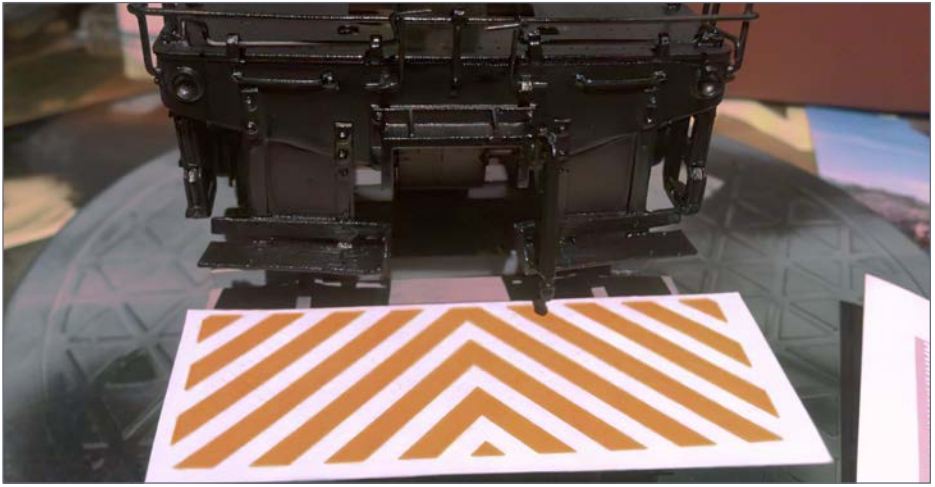

2. MRH forum member **transfer** has a problem: how to apply this tiger stripe decal to this loco pilot!

## Front chassis stripes decaling advice

MRH forum member **transfer** started a thread on the MRH forum about how to apply tiger stripe decals to a detailed loco pilot. Definitely a thorny problem!

*“What would you do after trimming the decal to maybe fit? Cut it in half? Go for it in one piece? Use Microsol ? Or Microset?”*

*Does anyone know how much time I have to place this decal?”*

Many helpful posts came from members such as **donm**:

*“First create a paper pattern. Cut out the overall size first, then slit to fit over protrusions, and finally trim to clear the coupler, step supports, and poling pockets.”*

You can find a lot more tips and helpful hints on this thread. Follow along to see how it turns out!

[View the full thread on the MRH website](#)



[REGISTER](#)  
*(free)*

[INDEX](#)

[TABLE OF CONTENTS](#)

The most detailed GP9RM  
on the market!

NOW  
IN STOCK

CN and MC  
versions

CLICK  
HERE

MAPLELEAF 

ADVERTISEMENT

ADVERTISEMENT

 **Archer**  
FINE TRANSFERS  
PROUDLY SERVING MODEL BUILDERS SINCE 1989  
THE ORIGINAL  
SURFACE DETAILS

We stock more than 200 different sheets of resin rivets, louvers, treadplate, weld beads and more for N, HO, S, O, G scale railroad as well as Armor and Aircraft so pass the word.

**LOW SHIPPING RATES**

(Shipping rates are posted in the banner of our home page)

▶ [CLICK HERE TO VISIT OUR WEBSITE!](#) ◀

NEW ADDRESS AND CONTACT INFORMATION

Archer Fine Transfers • 305 NW Railroad St. • Youngsville, NC 27596 • USA  
info@archertransfers.com • archertransfers.com

**DON'T BE A  
TURKEY,  
GOBBLE UP A  
PROTOThrottle  
THIS HOLIDAY  
SEASON!**



**TASTY  
Throttle!**



[MRHMAG.COM](http://MRHMAG.COM)

[INDEX](#)

[TABLE OF CONTENTS](#)



3. *MRH* forum member Paul Krentz has a regular layout construction blog on the *MRH* forum, with many fun progress photos.

## Pokey 3.0 construction

*MRH* forum member **p1dvdk** (Paul Krentz) is building a free-lanced layout based loosely on the N&W Pocahontas District. He started the blog in October 2020 with this entry:

*“It’s been a year-and-a-half since I tore down my last layout, so we could move. After a lot of remodeling work in the new house I’m glad to say that I’m finally able to begin construction on a new layout, the Pokey 3.0!”*

*Hope you will enjoy following along on this new adventure! I look forward to hearing all your comments and suggestions. They proved invaluable on my last layouts, and I know they will help me make this layout the best it can be as well.”*

Paul frequently posts progress photos and the discussion that ensues has been quite interesting and insightful. Become a regular follower of Paul’s Pokey 3.0 blog!

[View the full blog on the \*MRH\* website](#)



[REGISTER](#)  
*(free)*

[INDEX](#)

[TABLE OF CONTENTS](#)



## Before and after photos!

One particularly fun long-running thread on the *MRH* forum is called “Show us your before and after photos.” As you can see from the photos below, the transformation can be amazing and impressive. Check out the thread for many more fascinating and inspiring transformations!

View the full post on the *MRH* website



**RATE THIS ARTICLE**

4.5. *MRH* forum member **DaveB** (Jim D. Branum) took this toy train box car model and transformed it into a superb scale model of a contemporary SP hicube box car.



Give a gift from **MRH Media ...**



**Model Railroad  
Hobbyist *Store***  
Gift Certificate

DVDs, Paperbacks, eBooks, Video downloads



**TRAINMASTERS TV**  
Gift Certificate

Streaming video channel for people who love trains

**Achieve your  
hobby dreams**

**MRH**  
M E D I A



**REGISTER**  
*(free)*

[INDEX](#)

[TABLE OF CONTENTS](#)

# WHAT'S NEAT

column



Model Railroad Hobbyist | November 2021

## KEN PATTERSON COVERS THIS TIME:

- RADISSON MCGUIRE'S 1:87 SCALE MILITARY EQUIPMENT
- AN INTERVIEW WITH BACHMANN
- BUILDING A WALTHERS FIRE STATION
- FIRE APPARATUS IN 1:87 SCALE ...



*click to play video*

PHOTOS AND VIDEO OF SUPERB MODELS

**THIS MONTH RADISSON MCGUIRE VISITS KEN WITH A NEW COLLECTION** of combat ready 1:87 military models and Ken interviews Larry Harrington of Bachmann Trains. Ken then shows how he built an HO scale Walthers Fire Department Headquarters Building and a variety of 1:87 scale fire apparatus that could go with it. ☑



## Radisson McGuire's 1:87 scale military equipment collection



1. Radisson was on “What’s Neat” in July 2019, showing Ken some of the military models he had collected and built. He’s back with more vehicles, including models of combat ready vehicles. He also covers many of the models of vehicles that you might see on a modern military train. Radisson will be back next month with a segment on painting a vehicle in the NATO camouflage pattern.



**REGISTER**  
*(free)*

[INDEX](#)

[TABLE OF CONTENTS](#)



2. Among the vehicles Radisson brought were this M1070 Heavy Equipment Transporter(HET), seen here paired with an M1000 semi-trailer carrying an M1 Abrams tank. Radisson's model includes a detailed cab with photo-etched parts.



3. Radisson shows off a lineup of heavy armored vehicles, including two M1 Abrams tanks, an M1150 Assault Breacher Vehicle, an M88A2 Hercules tank recovery vehicle, a Buffalo MRAP, and an M9 ACE armored bulldozer.



## Ken interviews Larry Harrington of Bachmann Trains



4. Ken interviews Bachmann's Larry Harrington about some of their newest products, including the Siemens ALC-42 and smooth side passenger cars.



5. Here Larry shows the Siemens ALC-42 in the "Day 1 livery" paint scheme. Bachmann is doing only a single run of this paint scheme and it is pre-sold to dealers and distributors.

## Building Walthers Fire Department Headquarters kit



6. Ken starts building the Walthers Fire Department Headquarters by painting the parts while they are still on the sprues. He decided not to use an airbrush to paint this structure, instead using Rustoleum spray paint.



7. Ken uses a fine diamond file to clean up the nubs left from cutting the parts off the sprues. Next time he'll use flush-cutting sprue cutters to prevent this problem.

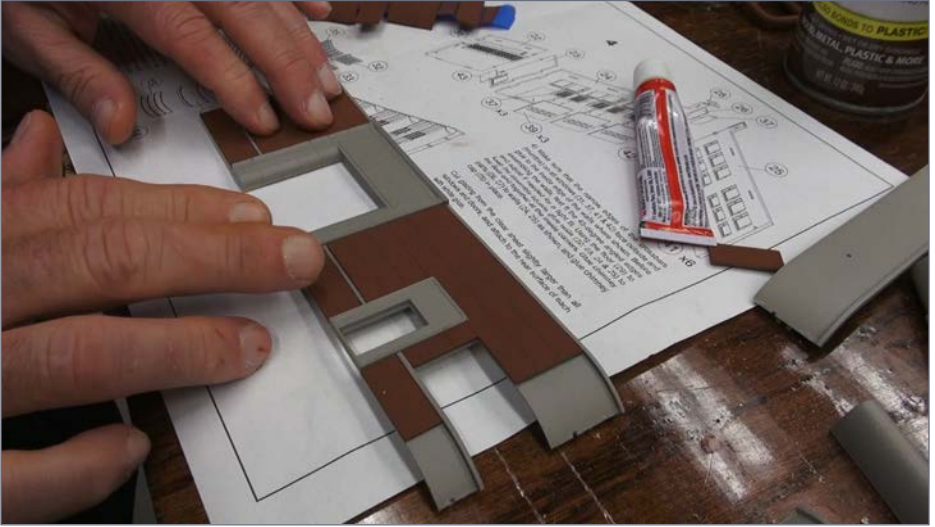

8. Ken uses Testors plastic glue from the tube to glue the brick inserts into the wall pieces.



9. After installing all the windows, Ken assembles the front three sides of the building, and test-fits them onto the base before adding the fourth wall.



[REGISTER](#)  
(free)

[INDEX](#)

[TABLE OF CONTENTS](#)





10. Ken puts glue onto the backs of the curved brick inserts and then simply places them into the walls.

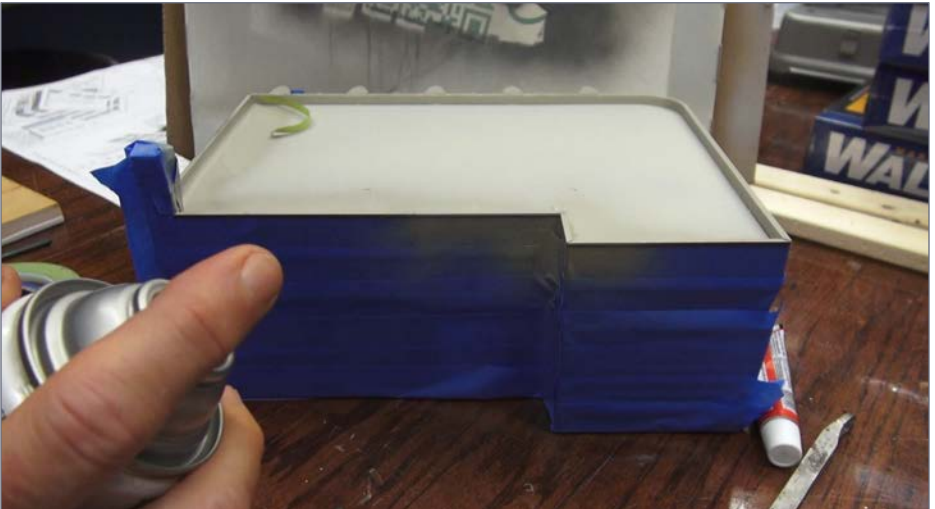

11. After assembling the entire structure and gluing on the roof, Ken masks the brick walls and sprays the trim on the top with the concrete gray paint he used on the non-brick walls.



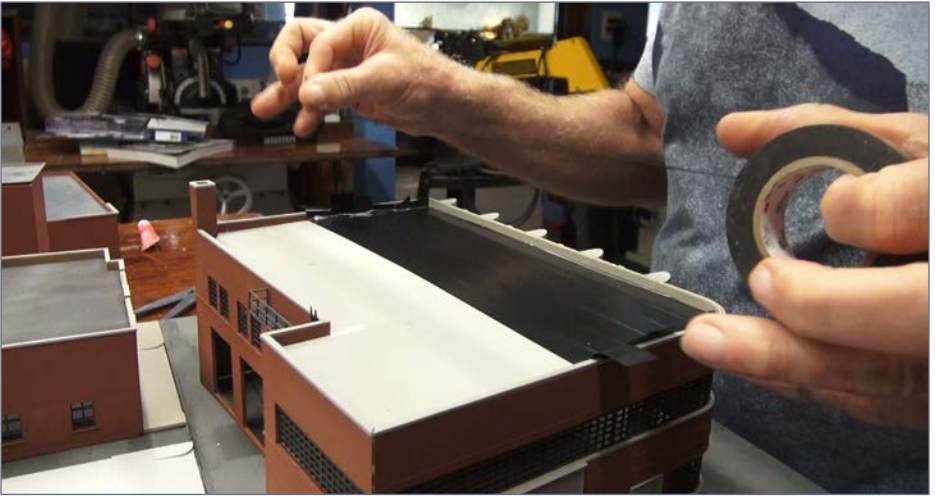

12. Ken uses rows of electrical tape to replicate rolled roofing. After trimming the tape, he'll apply flat black paint to the roof, and add some gloss black to represent tar lines.



13. After attaching the base, the building is complete and ready for photography.



**REGISTER**  
*(free)*

[INDEX](#)

[TABLE OF CONTENTS](#)

**Lasercut structures. Highway, storefront and billboard signs.**

**Neat ag customer for your railroad:  
Farmers Fertilizer Supply**



**WHAT'S  
NEW?**



**Established 1993...**

**Blair Line**

**LET'S GET LIT!**

**FREE SHIPPING  
CHECK 'EM OUT**

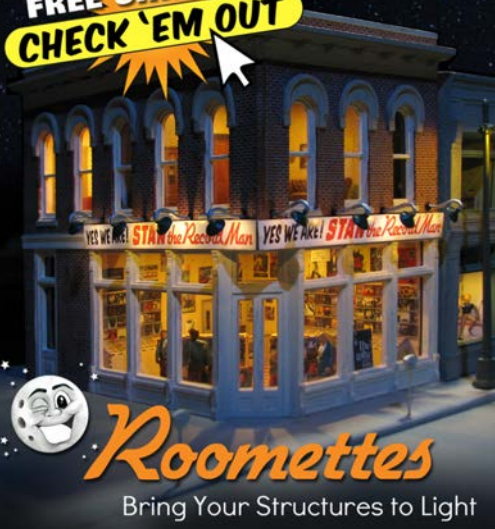

**Roomettes**

Bring Your Structures to Light

**Looking for Goose Sounds?**



Look no further! We have prototypical sounds for your Galloping Goose in our Tsunami2 Baldwin & Others decoders. This sound profile is available in most Tsunami2 decoder formats.

Available now at **SOUNDTRAXX**.com or your local retailer!



14. This shows the back side of the building with one of the bay doors installed in the down position.



15. Ken also built the Fire Department Drill Tower, used for training firefighters in carrying equipment up and down stairs, among other things.



REGISTER  
*(free)*

[INDEX](#)

[TABLE OF CONTENTS](#)





16. The Fire Department Repair Shop building can be used as an industry or utility repair shop or other building that needs to have vehicular access.



17. The Walthers Fire Department buildings fit together with a common look and color palette.

## Fire apparatus in 1:87 scale



18. Looking through the Walthers Catalog, Ken collected many of the available fire department vehicles, also referred to as fire apparatus, for this episode of “What’s Neat” and the September 11th episode of “What’s Neat This Week”:  
[youtu.be/fVrkJqfYpMA](https://youtu.be/fVrkJqfYpMA)

**Please include a phone  
number when emailing us if  
you *need* a reply!**

**( Just in case your spam filters eat  
our email response ... )**



REGISTER  
(free)

[INDEX](#)

[TABLE OF CONTENTS](#)



19. Two of the fire apparatus that Ken shows in the video are these Walther's Scenemaster Pumper and Hazmat trucks that have been modified by East Coast Circuits ([eastcoastcircuits.com](http://eastcoastcircuits.com)) with up to 42 solid and flashing LED lights in a single vehicle. To see all the military and fire vehicles, as well as the full interview with Larry Harrington and the complete fire station build, watch the What's Neat video linked at the beginning of this article. ■



**RATE THIS ARTICLE**

in the **NOVEMBER 2021 MRH RUNNING EXTRA!**

**Did you see this article?**



**Locating tiny non-magnetic screws**

**Get this eBook now ▶**

*click here*

**MRH** **RUNNING**  
EXTRA  
Each eBook ~100 pages



# Digit

## Introducing the UT6 & for Digitrax Comp



- **Compact size for easy one-hand**
- **Color 1.5" LCD Screen**
- **Full numeric keys for easy Loc**
- **Fine speed control with a large**
- **Removeable LocoNet® cord**
- **Forward/Reverse toggle switc**
- **Off/On switch, uses AA or BP6**

Find out more @ [www.](http://www.)



REGISTER  
(free)

[INDEX](#)

[TABLE OF CONTENTS](#)



# UT6D Utility Throttles Complete Train Control!

Handed operation

**UT6**

Utility Throttle

**\$105.00 MSRP**

Automotive selection

**UT6D**

Duplex Utility Throttle

**\$170.00 MSRP**

Encoder knob

With Braking

**View all features and *more*  
on our website!**

200MH batteries

**[digitrax.com/throttles/](http://digitrax.com/throttles/)**

Don't settle for all your locos  
sounding the same!

ESU now has **OVER 100**  
"LokSound" files to choose from!



Because "Close Enough" is no longer  
"Good Enough"

[LokSound.com](http://LokSound.com)



[REGISTER](#)  
(free)

[INDEX](#)

[TABLE OF CONTENTS](#)



# Automatic staging stopping blocks



Electrical  
Impulses

Model Railroad Hobbyist | November 2021

**GREG CIURPITA** SHOWS A SOLUTION FOR STOPPING TRAINS RELIABLY IN HIDDEN STAGING AREAS...



**MANY MODELERS RELY ON BLOCK DETECTION TO DETERMINE THAT A** train has completely entered a staging block. This can be challenging with hidden staging, momentum, and excessive speed.

One approach is an automatic stopping block at the end of the staging block that can be unpowered and automatically stop a train.

## AUTOMATIC STOPPING BLOCKS | 2

A 30-inch stop block should suffice for most HO-scale trains, even if the locomotives have stay-alive capacitors.

Of course this isn't very sophisticated, and does require additional block detectors. It makes sense to use a little bit of circuitry to make operation a little more reliable, especially for a distracted operator. As a bonus, cutting off power will reduce idle power requirements and sound levels.

A separate panel switch routes power to each staging track block, allowing you to cut off power. I've been working on several staging loops with three to five tracks, each long enough for two trains.

If a staging block is ~18 ft, six sections of flex track, the last section of flex track can be left isolated (gapped). You can isolate

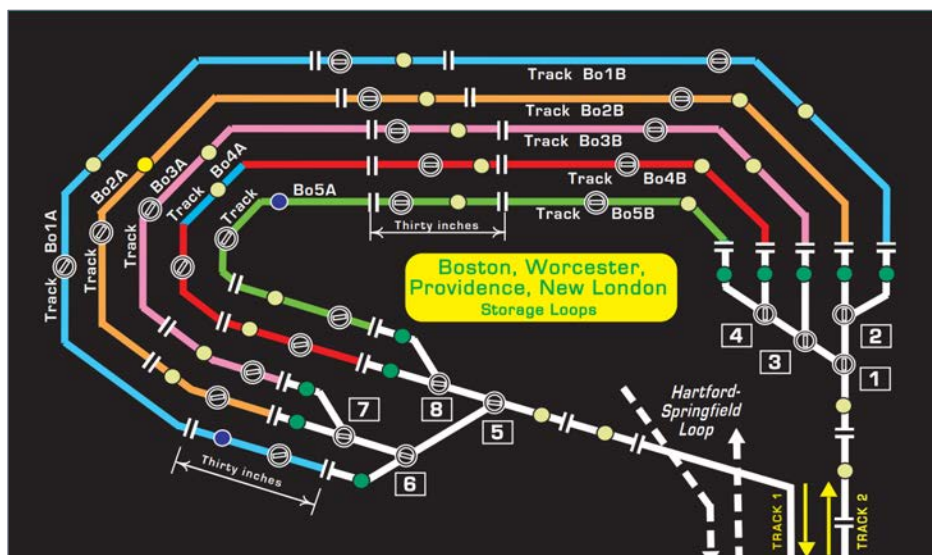

1. As you follow the train from Track 2 into Staging 1 (blue) from the bottom right, the train goes through two entrance blocks and an interlocking block with turnouts. It then enters Bo1B (Boston) block and a 30" stop block, and on to the Bo1A block and stop block before exiting through the interlocking and back to Track 1.

ADVERTISEMENT

**RailPro**™

**NEW  
TECHNOLOGY**

**RE RING**™  
ENGINEERING

# DCC + RADIO CONTROL

HO Scale Locomotive Module

**ULTIMATE  
SERIES  
SOUNDS**

**TRUE  
MOTION  
TECHNOLOGY**

**LIGHT  
EFFECT  
EDITOR**



New Sound Technology and Mathematical Model Motion Control + more!!!



+



Equals  
"DUAL MODE"  
Control by DCC +  
Radio Control

**Click Here to  
Watch Video**

For more information visit our Internet site: [www.RingEngineering.com](http://www.RingEngineering.com)

ADVERTISEMENT

## STREAMLINED BACKSHOP

Sales ... Service ... Solutions ...



# WOWSound ?

[WWW.SBS4DCC.COM](http://WWW.SBS4DCC.COM)



LOK SOUND  
EST. 1999



SOUNDTRAXX



[MRHMAG.COM](http://MRHMAG.COM)

[INDEX](#)

[TABLE OF CONTENTS](#)



the last segment as a stop block. The panel diagram shows a five-track staging loop. In the diagram, each staging loop stores two trains. Each loop is divided in half, and each half divided into 2 blocks – two main blocks and two stopping blocks [1].

Each of the staging blocks, including the main and stopping blocks, have block detectors, panel LEDs and switches to cut off power. All the switches have a 1K resistor wired across them to limit power but low enough to allow sufficient current for the detectors to indicate occupancy even when the switch is off.

Consider a train intended to stop in staging track block Bo1B with a train occupying block Bo1A. Operation is as follows:

- Turn on the Bo1B main block and verify the Bo1B stopping block is off.
- Train enters the staging area at a reasonably slow speed and proceeds through the entrance blocks.
- The main Bo1B block detector should indicate when the train has entered the main block
- The stop block detector will indicate when the train enters the stop block and the train should come to a stop.
- Turn off the switch for the main staging block, especially if there is an engine consist.
- Set the throttle to zero. With the stopping block unpowered, there's no hurry.

Exiting staging from Bo1A is as you would expect:

- Turn on the switches for both the main and stopping blocks.
- Throttle the train up to take it out of staging.
- Turn off the stopping block, leaving the main block on for the next train entering staging.

If there is a train in the second staging block (Bo1B), it needs to be moved up:





# Southern Digital

WWW.SODIGI.COM

Celebrating 28 Years serving you

## All New Items from **DigiTrax** Complete Train Control



Evolution Express Duplex Radio  
List \$645, Your Price \$516



Evolution Express  
List \$460, Your Price \$365



DT602D Radio Throttle  
List \$260  
Your Price \$208



UT6D Radio Utility Throttle  
List \$170  
Your Price \$136



DT602 Super Throttle  
List \$195  
Your Price \$156



UT6 Utility Throttle  
List \$105  
Your Price \$84



UR93 Duplex Receiver  
List \$125  
Your Price \$99.95



BD4N Block Detector  
List \$36  
Your Price \$29



BXPA1 Auto Reverser  
List \$49  
Your Price \$39



Ni-MH Battery for  
DT602 or UT6  
List \$12  
Your Price \$9.60

## DCC Conversions, Service & Support

E-mail: [sales@sodigi.com](mailto:sales@sodigi.com) (770) 929-1888





YOUR HEADQUARTERS DCC

*Litchfield*

**S T A T I O N**

***GREAT GIFT IDEAS!***  
NCE | Digitrax | Speakers  
SoundTraxx  
Train Control Systems  
ESU LokSound  
Tam Valley Depot  
RailPro

The advertisement features a central graphic of a black and orange train engine. Above the train, the word "Litchfield" is written in a large, elegant cursive font, with "STATION" in bold, black, spaced-out capital letters below it. To the left, a signpost with two wooden posts has two grey signs that read "YOUR HEADQUARTERS" and "DCC". In the top right and bottom right corners, there are two wrapped gift boxes made of brown paper, tied with twine, and decorated with green pine branches.

[www.LitchfieldStation.com](http://www.LitchfieldStation.com)  
[sales@litchfieldstation.com](mailto:sales@litchfieldstation.com)  
623-298-7355



**REGISTER**  
*(free)*

[INDEX](#)

[TABLE OF CONTENTS](#)

# AUTOMATIC STOPPING BLOCKS | 4

- Turn on the Bo1A main and both Bo1B blocks and verify the Bo1A stop block is off.
- Throttle up to move the train
- The train should stop as it reaches the Bo1A stop block.
- Turn off both Bo1A blocks and the Bo1B stopping block.
- Set the throttle to zero.

With alert operators, this is unnecessary. A short block at the end of staging makes it easier to know when a train is near the end of the staging block, even without the power switch.

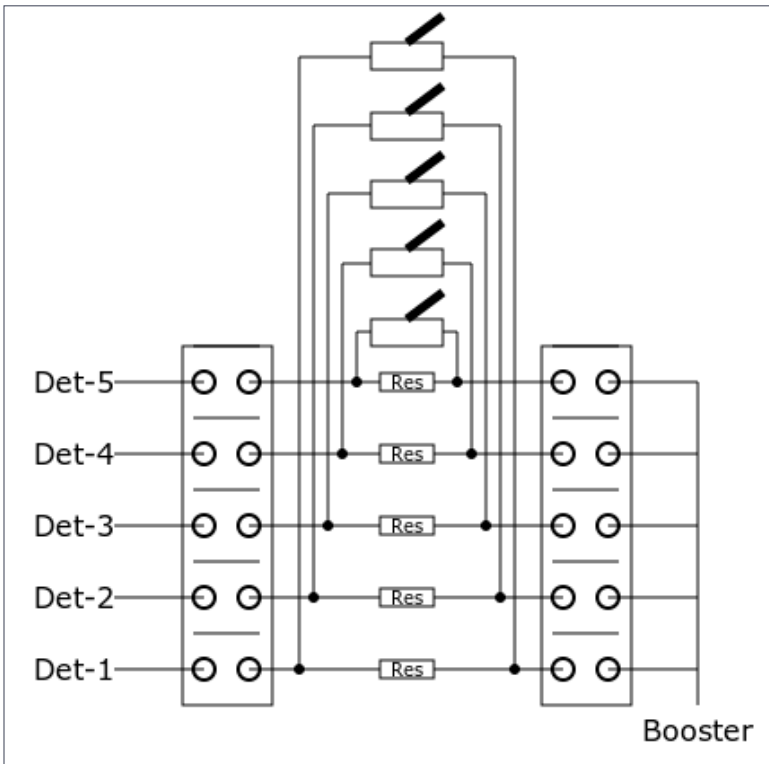

## 2. Panel switch wiring.



## PANEL WIRING

There are several approaches for wiring the panel to minimize confusion. The diagram illustrates the wiring for five tracks, conceivably main blocks Bo1A-Bo5A. You can use larger barrier strips as needed [2].

This panel has a pair of barrier strips for each panel switch. All the terminals along one edge of one barrier strip are wired to the booster.

Each terminal of the second barrier strip is wired to a block detector. A resistor is wired between the pair of barrier strips and each panel switch is wired in parallel with the resistor to the same barrier strip terminals [2].

This approach with resistors wired between barrier strips avoids soldering a resistor across each switch. Bringing the

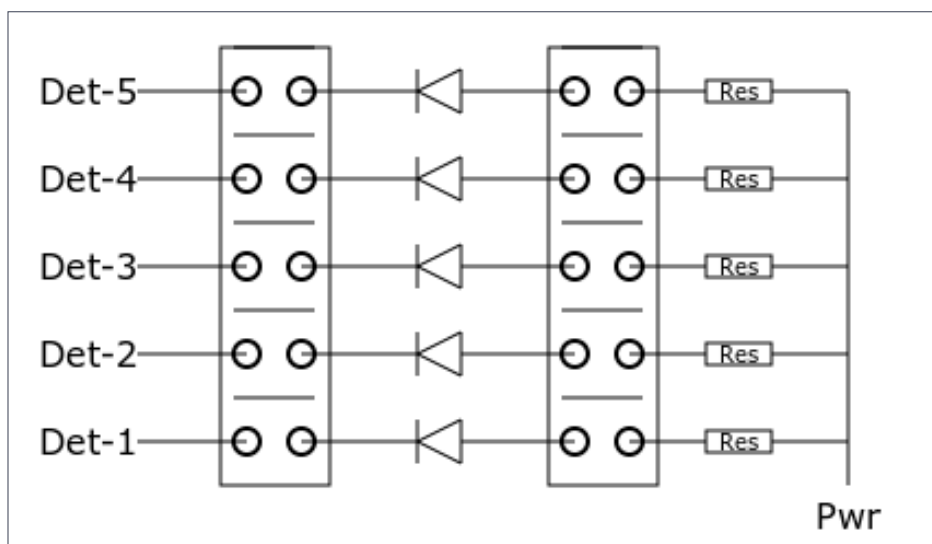

### 3. Panel LED wiring.

**TamValleyDepot.com**



Home of the  
Frog Juicer

## Dual Frog Juicer

Automatic DCC Polarity  
Reverser can be used to:

- Power Two Frogs
- Crossovers
- Crossings
- Automatic Reverser for  
Turntables
- Wyes, Loops
- Circuit Breaker

Use with 2-10 Amp Systems

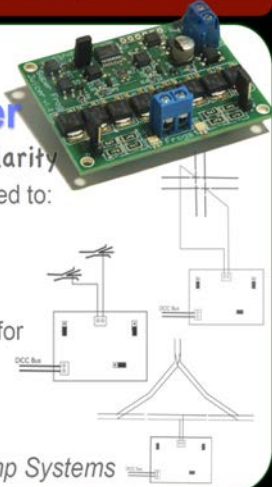

Your ad here  
could reach  
65,000+  
for as low as  
\$222 a month.

Click to learn more ...

ADVERTISEMENT

Make LocoNet wiring extremely simple!



**ACCU-LITES, inc**

Your DCC Center!



Suitcases belong in your baggage  
cars, not under your layout!

Check out the DCC Vampire II ...

This guy does the job of two suitcase connectors!

And really holds the connection good too!

**CLICK NOW TO DISCOVER THE AMAZING VALUE!**



Dealer Inquiries Accepted

booster connection into the panel also minimizes wiring by requiring only one wire from the panel to each detector.

Additional wires are needed from the detector to drive the panel LEDs [3].

These can also be similarly wired to a pair of barrier strips with either ground or power (e.g. 5V) replacing the "Booster" connection.

An LED replaces the resistor between the barrier strips. A resistor could be between the common ground/power and each barrier strip terminal instead, avoiding the need to solder resistors in series with each LED.

## GREG CIURPITA



Model railroading motivated Greg to become an electrical engineer, and is a retired embedded firmware developer using those skills helping others build and maintain their layouts. ■



**RATE THIS ARTICLE**

in the **NOVEMBER 2021 MRH RUNNING EXTRA!**

**Did you see this article?**



**Narrowing your  
layout scope**

**Get this eBook now ▶**

*click here*

**MRH** **RUNNING**  
EXTRA  
Each eBook ~100 pages



**REGISTER**  
(free)

[INDEX](#)

[TABLE OF CONTENTS](#)

# END OF TRAIN DEVICE

**NEW SAFETY GREEN**



Patented Technology - US Patent 7,549,609

**Bright Red  
Flashing Light!**

Installs in minutes!  
No freight car  
modification required!

**Does not affect Load!**

↓ Car without Load ↓

↓ Car with Load ↓



**Click Here to  
Learn More**

**RE RING™  
ENGINEERING**

ADVERTISEMENT

## Great control in a tiny package



**Original  
Touch Toggles**

- Touch Toggle™ plug in controls
- Bright clear indication
- Easy setup
- Flexible system

Stall Motors, Twin-coils,  
Power, and Servos

Now for Tam Valley Depot  
and MRservo too!



Made in the USA



What will they think of next?

[www.berretthillshop.com](http://www.berretthillshop.com)



# From first train set to railroad empire...

*Our complete line of DCC products  
grows with you. Discover the fun!*

- Designed and manufactured in the U.S.A.
- Preferred for ease of use and ergonomic design
- Unlimited scalability for any size model railroad
- Plug-and-play means more time running trains
- Great customer service and excellent support



## See your dealer



REGISTER  
*(free)*

[INDEX](#)

[TABLE OF CONTENTS](#)



## Visit our new and improved web site for all your DCC needs!

- Get the latest new product announcements
- Watch our detailed how-to videos
- Browse the all-new Information Station
- Enjoy secure online sales, day or night!

Visit **ncedcc.com**



# MRRH MARKETPLACE



Learn more ...

Get Yours Now! ▶



ModelTreeStore



Wood Craftsman Kits  
Visit [Conowingomodels.com](http://Conowingomodels.com)



### Grade Crossing Pro/2

Photocell, IR or current sensing detection  
Improved infrared detection!  
Optional on-board bell modules  
Timing options for flashers, gates, and bell  
Use slow motion motors or servos with your gates

Please visit our website and online store!

**LOGIC RAIL™**  
TECHNOLOGIES

[info@logicrailtech.com](mailto:info@logicrailtech.com)

(281) 251-5813

[www.logicrailtech.com](http://www.logicrailtech.com)



## 4 NEW WEATHERING POWDER SETS



AVAILABLE AT:

[www.monroemodels.us](http://www.monroemodels.us)

## NEW CREATIONS



VICTORIAN RAILROAD BUILDINGS, LLC  
[newcreationsvictorian.com](http://newcreationsvictorian.com)



REGISTER  
(free)

[INDEX](#)

[TABLE OF CONTENTS](#)



## mini prints



Craftsman-quality 3D printed miniature railroad animals, figures and scenic details

[miniprints.com](http://miniprints.com)

make your model railroad come alive

**MOUNTAIN SUBDIVISION HOBBIES**

[www.modelrrsupply.com](http://www.modelrrsupply.com)

FREE USA SHIPPING OVER \$49.00

MRH Readers save with code:

**MRHMAG19**

**SOUTHWESTERN RAIL SYSTEMS**

*Electronics for Modular Model Railroads*

Home of the FMTP, the Free-mo Throttle Panel

The FMTP combines the functionality of a panel-mounted throttle hub with an adjustable DC output for running accessories such as lights and/or turnout motors

[Click this ad to visit our shop for details >>](#)

**Model Railroad Control Systems**

Geoff Bunza Project Boards

DCC Occupancy Detectors

CMRInet Compatible Nodes

Layout Telephone Systems

RFID Switchlist Generator

Switch Machines and Drivers



LOOK  
at what's new at  
Black Cat this month

Click here for  
our website

**Etched CPR Van  
Phosphor-bronze splash  
guard & end ladders**



**Black Cat Publishing**  
(204)489-5005  
[ajfergus@mymts.net](mailto:ajfergus@mymts.net)  
[blackcatdecals.com](http://blackcatdecals.com)



**PRECISION DESIGN CO.**

**CUSTOM DECALS FROM  
YOUR OWN ART IN JUST ONE DAY**

**PDC.CA**

**FULL COLOR & SOLID WHITE**

*click to learn more!*



**East Coast Circuits**  
Innovating Your Model Railroad Layout

P.O. Box 25412  
Providence, RI 02905

Lighting Circuits For Your Layout

Random Lighting Circuit - Burning Fire Circuit  
Traffic Light Circuit - Crossing Signal Circuit

Custom Lighted Vehicles  
HO & O Scale Emergency Vehicles  
HO & O Scale Trucks & Cars

[Eastcoastcircuits.com](http://Eastcoastcircuits.com)

[Eastcoastcircuits@gmail.com](mailto:Eastcoastcircuits@gmail.com)

**Bridge the gap**

... with Mountain Pacific Scenics



Click to  
learn more ...



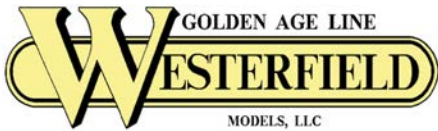

**NEW KIT: AT&SF  
Fe-Q/Fe-R/Fe-V**



[westerfieldmodels.com](http://westerfieldmodels.com)



The advertisement features a red and white background. At the top, the 'Imagine That! Laser Art Products' logo is written in a cursive font. Below it, the text 'ITLA Scale Models' is in a bold, black, sans-serif font. Underneath, 'Grimsby Station - HO Scale Precision Laser Cut-Wood Kit' is written in a smaller, black, sans-serif font. The central image shows a detailed model of a station building with a sign that says 'GRIMSBY'. A train is visible on the tracks in front of the station. At the bottom, a white oval contains the text 'CLICK HERE FOR MORE INFORMATION' and the website 'www.itlascalemodels.com'.

When talking  
to hobby  
vendors,  
please  
remember to  
mention MRH.



**Squeaky's Trains**

Handcrafted & Exclusive Models  
DCC Products, Service, Installations

Let's play with trains!

Offering:  
SoundTraxx, TCS, NixTrainz,  
Atlas, RailPro, MTO Battery, Kadde,  
and many more Railroading Supplies!



[SqueakysTrains.com](http://SqueakysTrains.com)



**REGISTER**  
(free)

[INDEX](#)

[TABLE OF CONTENTS](#)

**INTER-ACTION**  
Hobbies  
Preserving History in Miniature

*"Got a Smoke?"*



Kit HO-5032

[www.interactionhobbies.com](http://www.interactionhobbies.com)

**PRE-SIZE**  
MODEL SPECIALTIES

P.O. Box 6 Paonia, CO 81428  
Ph. 970 527 4586  
Made in The USA

Cast resin items for All Scales.  
Tunnel portals, bridge piers, abutments, culverts, and retaining walls.  
Trackside details and sage brush tree armatures.

*"FREE SHIPPING see website for details"*

**MONASHEE**  
**LASER**  
**ENGINEERING**

**COME VISIT US**  
**CLICK HERE**

MANUFACTURERS OF FINE RAILROAD  
STRUCTURES AND ROLLING STOCK MODEL KITS

Your ad here could reach 65,000+ for as low as \$88 a month.

*Click to learn more ...*

**WE'RE BEHIND YOU ALL THE WAY**

**Sceniking**.com  
*...nothing compares...*  
*Click to learn why!*

**Great Decals!**<sup>TM</sup>  
FEC, Interstate, Virginian Railway, & L&N Titles  
After Hours Graphics Line  
Coupler Gages and More  
In O, S, HO, and N Scales

**Human[city] Junction**  
Model Railroad Videos | Tutorials, Reviews, Interviews, Hangouts

**YouTube Channel Sponsored By**  
CMR Products | 7% off on House Brands  
Iron Planet Hobbies | 10% off and Free Shipping in the USA

**Use Discount Code "HUMAN"**

Please visit us out at [www.humancityjunction.com](http://www.humancityjunction.com)

*click me!*



**Pursuing Excellence**

**THE TRAINMASTER, LLC**  
Detailed Craftsman Kits

[www.TheTrainMaster.com](http://www.TheTrainMaster.com)

# EXTREME WEATHERING



**NICK CAMPBELL** FADES, WEATHERS, RUSTS,  
AND ADDS GRAFFITI TO A PULLMAN STANDARD  
HOPPER FROM TANGENT MODELS ...



**REGISTER**  
*(free)*

[INDEX](#)

[TABLE OF CONTENTS](#)









**I CHOSE A PROTOTYPE I FOUND ON “THE RUSTBUCKET” FORUM** from Matt Guerrant. The car had fading, bleed-through, ghosting, patches, heavy grime/dirt, rusting, and spillage. After seeing the photos, I just had to take on the challenge of modeling it.

Here is the primary side first followed by the "other side" which was a different but similar hopper, as I didn't have photos of both sides of #15322 [1, 2].

The techniques I used reflect those I've seen from other artists on “The Weathering Shop” website. Gary Christensen especially had a “color transition fade” I found indispensable to weathering this hopper [3].



1. I could not resist modeling AEX 15322, an ex-CNW hopper. But I only had photos of this side of the car to work with.





2. For the other side of the car, I chose AEX 15334. Not the same car, but it'll do.



3. I began with an out-of-the-box model from Tangent.

I began by washing the model with mild dish soap and a soft brush. From this point until the final clearcoat sealant was thoroughly dry, I did not handle the model without wearing latex gloves.

Once the model was dry, I sprayed it with a coat of Testors Dullcote to give the surface “tooth” for weathering. I set the body aside and moved to work on the wheels and trucks.

## WEATHERING THE TRUCKS

Although Tangent’s model is wonderfully detailed overall, the wheels do not have a proper back profile. This bothers me because they are highly visible through the end cages. I opted to substitute a pair of Athearn Genesis 100-ton trucks with 0.88” tread width [4-7].

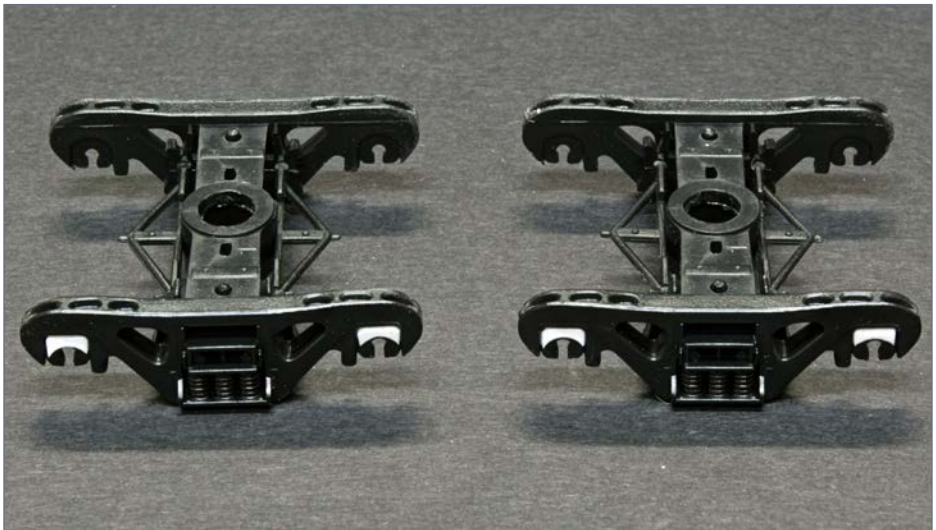

4. The downside to the Athearn trucks is that they have a deep void where the axle bearing should be. I scratchbuilt and added my own (light gray).





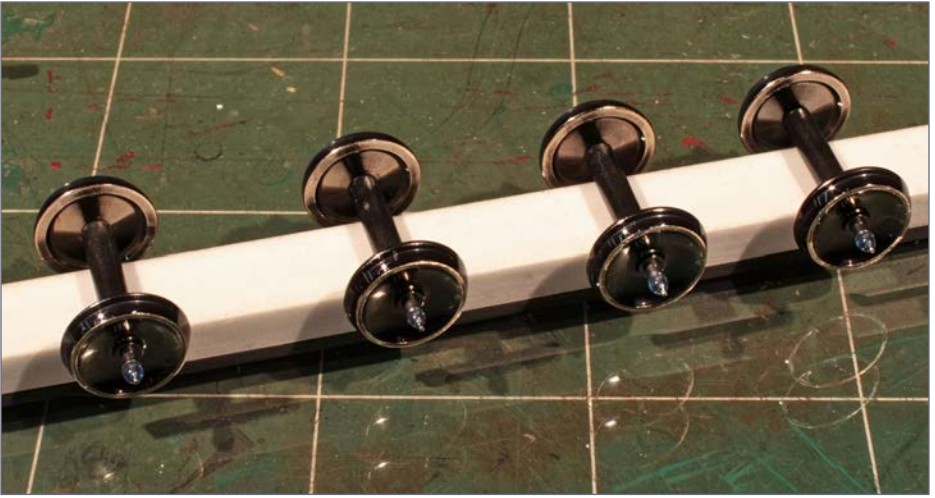

5. I used 800-grit sandpaper to rough up the surface of the wheels for better paint adhesion. I used Microscale's Micro Mask on the wheelsets' threads and needle bearings. Because Micro Mask is a liquid, I had to turn the wheels constantly until it had set enough to not flow to the lower side.



6. I sprayed the trucks and wheelsets with Rustoleum dark gray auto primer to give everything a uniform dark color.





7. I prepared a series of washes using inexpensive craft acrylic paints and water, based off colors I saw in the prototype photos. I applied five washes of burnt umber, two of burnt sienna, and a final wash of gray. I gave the wheels and axles the same treatment.

## FADING PAINT



8. I used a fresh X-Acto blade and gently scraped off the black ink from the yellow CNW lettering. I errantly roughed-up the surrounding surface, but it should not be noticeable when the model is complete.



REGISTER  
*(free)*

[INDEX](#)

[TABLE OF CONTENTS](#)

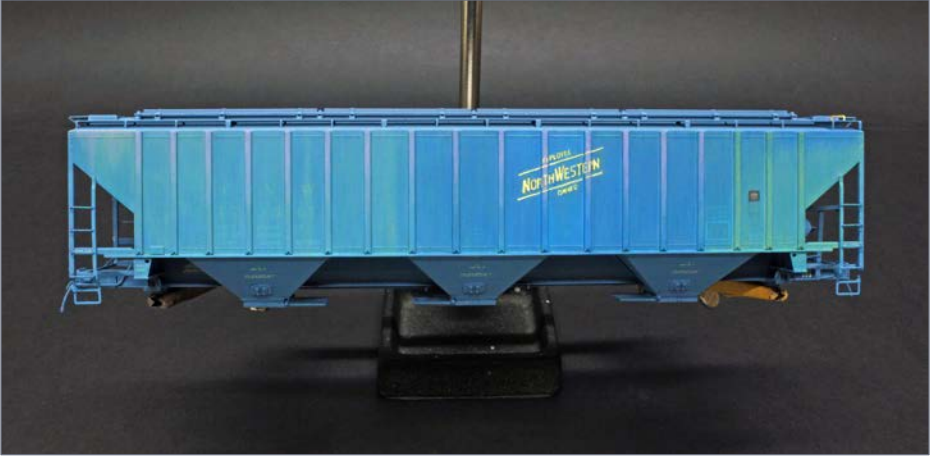

9. I began with very thin washes of light blue. I followed with washes of dark blue, green and orchid. The herald would almost disappear every few washes, so I used a damp toothpick to clean paint away.



10. I applied several washes of orchid to the roof. I transitioned the roof hatches from blue to white with successive washes.



11. On to the other side of the car, I applied the light blue washes as on the other side. Then I applied light and dark green washes successively until I had the look I wanted.



12. I began with my orchid base wash and applied washes of orange and red to better match the prototype color. I used a sharp X-Acto blade to chip away paint from the ribs and allowed the orchid wash to run down the sides of a few.



**REGISTER**  
*(free)*

[INDEX](#)

[TABLE OF CONTENTS](#)

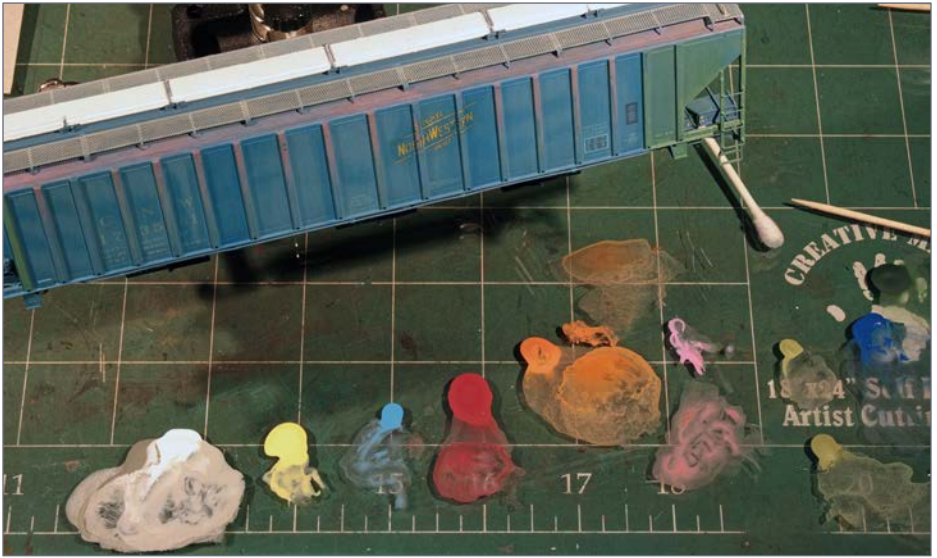

13. I dry-brushed highly thinned darker blue colors onto the side for color variation. As you can see from the glass on my workbench, I have mixed and used many color washes on this model so far.



14. I used the same process to fade the paint on the car's ends as I did for the sides.



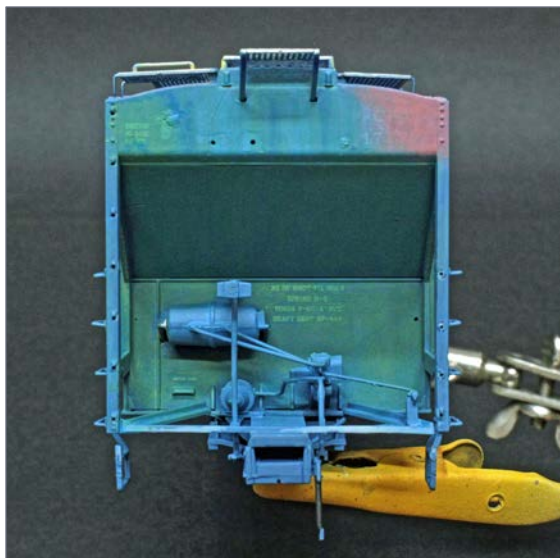

15. The brake end.

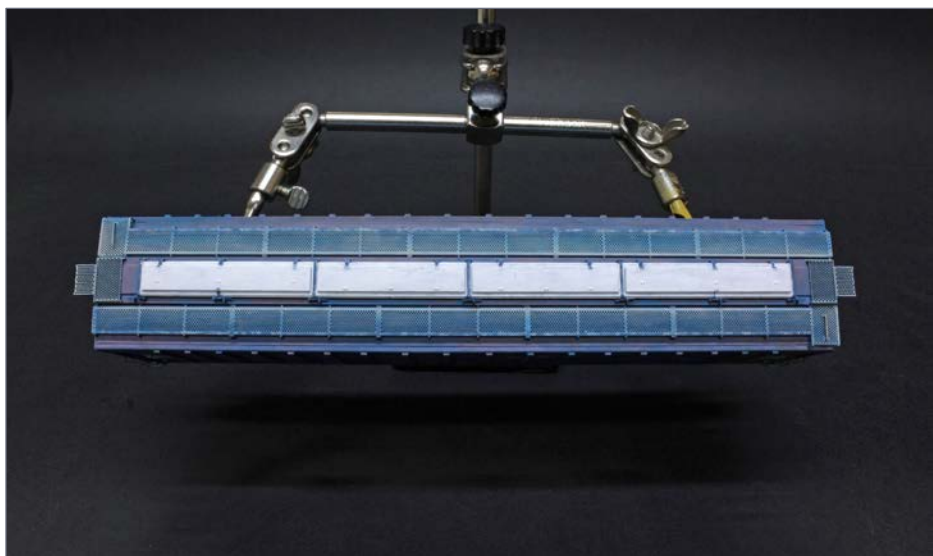

16. For the roof walk, I used a series of gray washes. I then gently scraped off the wash for a chipping effect. I also filled-in the roof weathering down the center of the car.



## GETTING DIRTY



17. I Started with a clean car bottom.



18. I applied a layer of dark brown, almost black grime to the bottom of the car. I used a series of highly thinned acrylic paint washes of burnt umber and black to achieve the effect.



19. The next layer of filth on the prototype appeared to be tan dirt/dust. I made a wash with a color called territorial beige to replicate it. I layered washes to achieve a light-to-heavy "dirt" build-up with the heaviest being towards the bottom.



20. I repeated the process of applying burnt umber and black washes to add a grimy look to the car ends. Here we see the brake end.



REGISTER  
(free)

[INDEX](#)

[TABLE OF CONTENTS](#)



21. I used gouache paints to represent wheel splatter on the car ends. Gouache manipulates nicely. I applied it with a sharpened toothpick.



22. I replaced the end cages and gave them the same grime treatment I used on the bottom and ends. I did the inside of the cages while they were still off the car. Here we see the brake end.



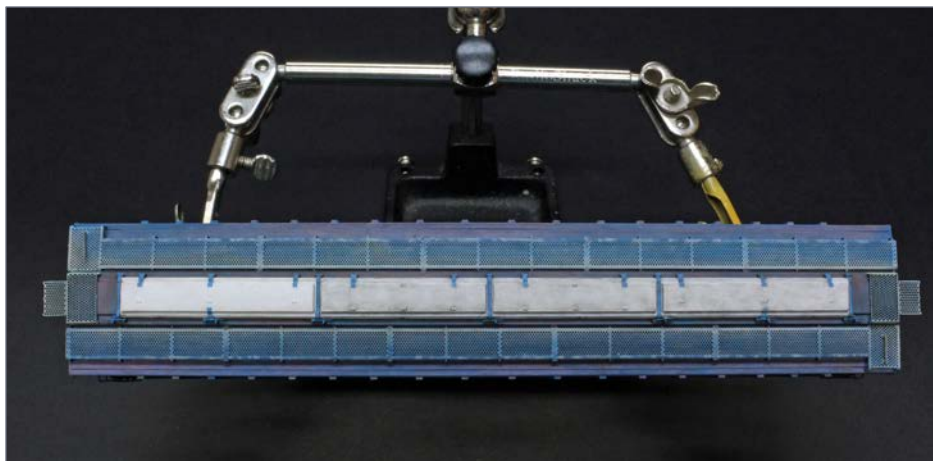

23. I used a mix of white and black gouache to put gray grime on the hatches.

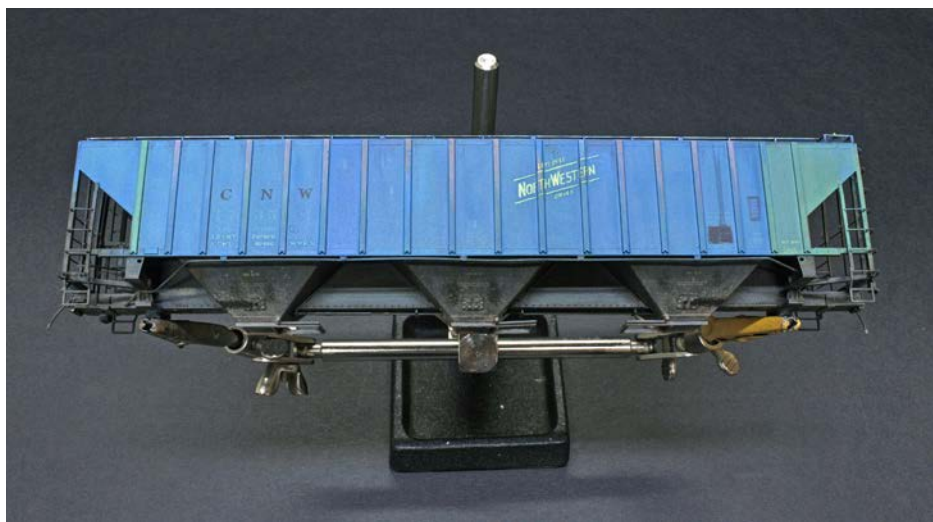

24. I used a very fine liner brush and diluted black acrylic to paint the CNW reporting marks to begin the ghosting effect. I used a sharpened damp toothpick to erase any errors. Note the dark blue streaking I added elsewhere on the car using the dry-brushing technique.



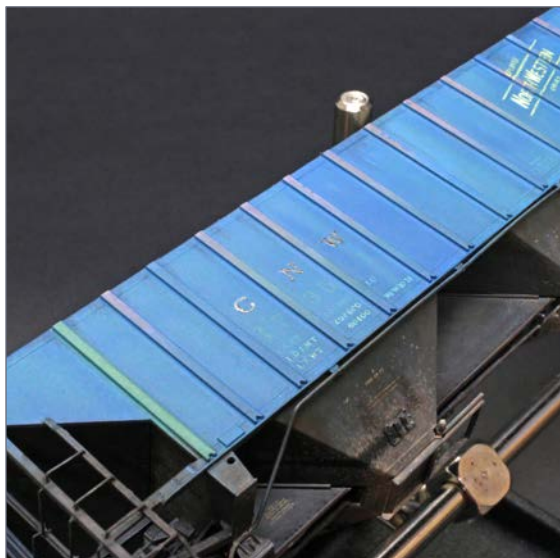

25. I applied Future acrylic floor wax directly over the CNW reporting marks with a fine liner brush. This gave the reporting mark a smooth surface so that I could remove the patch paint easily from the lettering later.



26. I applied patches using thinned white acrylics. I used a sharpened damp toothpick to remove buildup on the CNW lettering and to keep the patch outlines clean.



27. The prototype photos showed several colors of patchwork in addition to the white. I replicated that by layering several colors of craft acrylic paints, again working in very thin application layers.



28. I added patches to the ends using the same technique. Working in thin layers allows for easy cleanup, and allows the paint to stay at a scale thickness.



REGISTER  
*(free)*

[INDEX](#)

[TABLE OF CONTENTS](#)



29. I used black and raw umber gouache paint to add wheel splatter to the bays' undersides.

## RUST IN PEACE



30. I added heavy side rusting and grime using heavily thinned burnt umber and black acrylics. I especially concentrated on the sides of the ribs. The end decals are in place.





31. I added the reporting mark and other decals to the non-ghosted side, then added additional layers of rust and grime using using an almost dry (damp) brushed, heavily thinned burnt umber and black acrylics. Washes of brown and gray on the bottom represent more grime.



32. For the ghosted side, I used much the same process for decaling and weathering. In addition, I used water-soluble burnt sienna oil paint to create the underlying hue for rust. I used Van Dyke Red oil paint for some of the heaviest rust areas. I followed this with the washes of brown and gray craft acrylics.



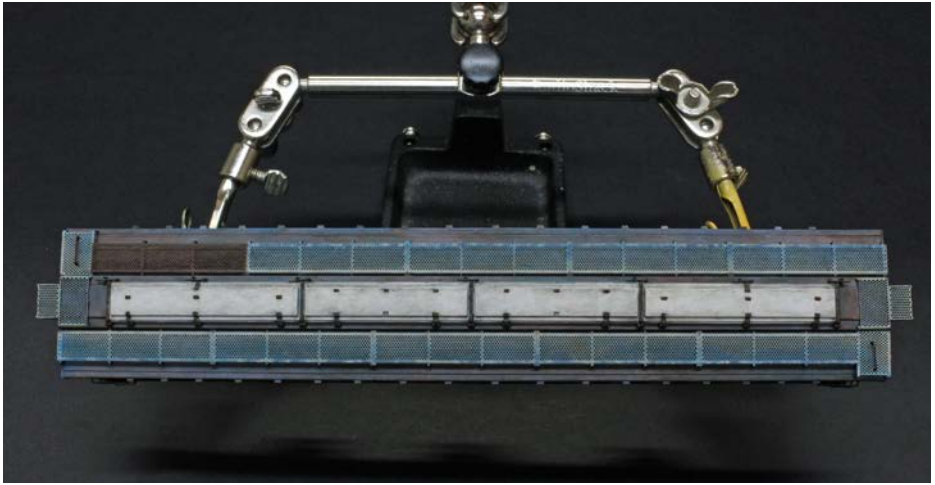

33. I rusted a section of the roof walk completely and dirtied-up the hatches some more.

With the fading, weathering, and rusting steps completed, I added another ultra-light dusting of gray to represent road dust. When the dust layer was dry, I sealed the work with a sprayed layer of Dullcote. Since I would be using water-based acrylics for the graffiti, I wanted a solvent-based seal to protect the work I had done so far.

in the **NOVEMBER 2021 MRH RUNNING EXTRA!**

**Did you see this article?**



**Modeling Kansas City  
passenger facilities**

**Get this eBook now ▶**

*click here*

**MRH** **RUNNING**  
EXTRA  
Each eBook ~100 pages





34. I began the graffiti process by adding reflective striping to the car's ribs per photos. I then proceeded to use my ultra-fine liner brush and thinned acrylics to paint the graffiti. I began in white and worked in layers, adding other colors in as needed, for about 10 layers total. As always, I cleaned up any blemishes with a sharpened wet toothpick.



35. I used oil paint to represent graffiti overspray in some areas. To prepare the paint, I dabbed a small amount onto a piece of cardboard so the carrier oil could leach out and leave behind more pigment. I then applied the paint with a very small, stiff brush.



A final seal of Dullcote finished the paint work. I installed the couplers, trucks, brake wheel chain and cut levers. Total time on this model was about 81 hours.



36. The finished ghosted side of the model with graffiti.



37. The finished non-ghosted side, as yet untagged per prototype photos.



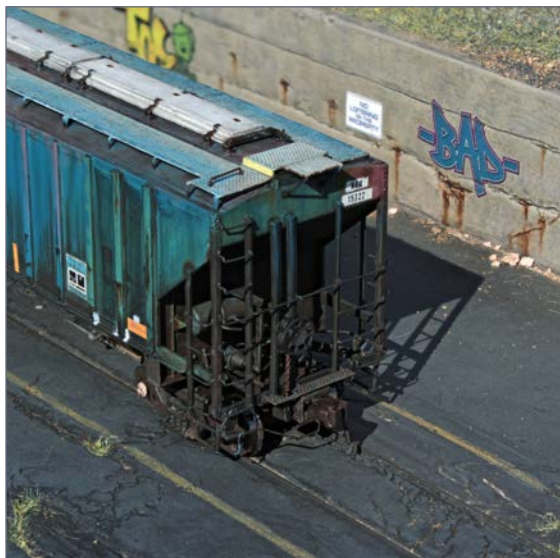

38. The finished brake end of the car.

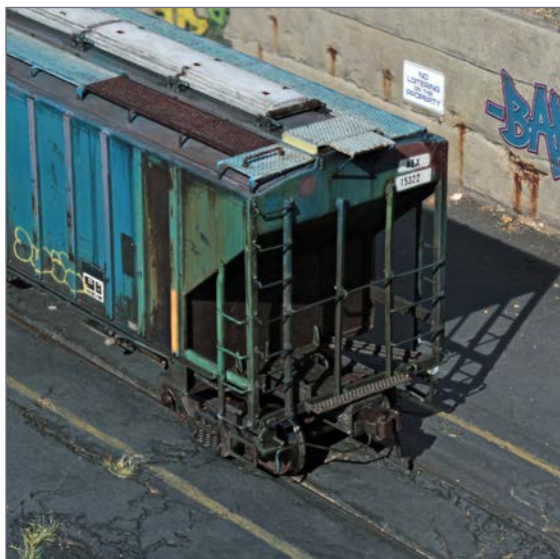

39. The finished non-brake end of the car.



REGISTER  
(free)

[INDEX](#)

[TABLE OF CONTENTS](#)

## NICK CAMPBELL



As a boy, Nick often accompanied his grandfather on errands. When he would see a train coming, his Grandpa would pull his truck over to the side of the road to watch. As the train roared by, shaking the truck, it always left an impression on Nick, as did the tuxedo scheme of the Southern Railway.

Train sets Nick received as Christmas gifts from his father between the ages of five and 11 planted another seed. After an absence from the hobby during early adulthood, Nick stopped in a hobby shop, and the train bug bit again!

He was hooked, and a trickle of new models (rolling stock/engines) began to find their way to his home, and he began a layout.

During the layout-building phase, and a very regular internet search on model railroading questions, Nick stumbled upon the "The Weathering Shop" website. Being a visual artist already, seeing these models transformed into miniature replicas of reality was fascinating to him. "The Weathering Shop" has a forum called "The Rustbucket." Just about every technique he has employed was found on "The Rustbucket." The tutorials and answers to questions about how to accomplish weathering goals have been invaluable.

What started as an art project has turned into prototype modeling. Nick hopes to continue to learn new techniques and produce many more accurate models. ■



**RATE THIS ARTICLE**

# WHAT'S NEW on TMTV!

Non-members: Watch episodes for \$1.99 ea, become a member for unlimited access

Brought to  
you by  
**MRH**  
MODEL RAILROAD HOBBYIST

## No mess foam scenery-3: Finishing the scene



# BACKSHOP CLINIC

### Exploring the hobby's roots

QAT  
#9

MRH Hobby News staffer Richard Bale was there! He talks about rubbing shoulders with John Allen, Irv Altham, the Kadee twins, and other hobby greats.



Joe Fugate



Richard Bale



Plus we get a live tour  
of Randy Lee Decker's  
Game & Depot'd  
resurrection project!

**MRH  
QAT**

MRH Questions, Answers, and Tips

Recorded on  
Saturday, Sep 18th

### Exploring the hobby's roots

### Final 3D printing prep

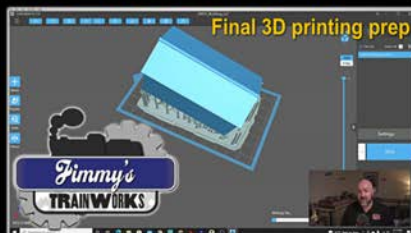

### Slicing a 3D design for printing



### Quick-n-easy bushes



### Photo editing for modelers



# TRAINMASTERS.TV

Don't miss out on these videos! **CLICK NOW**



**REGISTER**  
(free)

[INDEX](#)

[TABLE OF CONTENTS](#)

# Modeling tar paper roofs

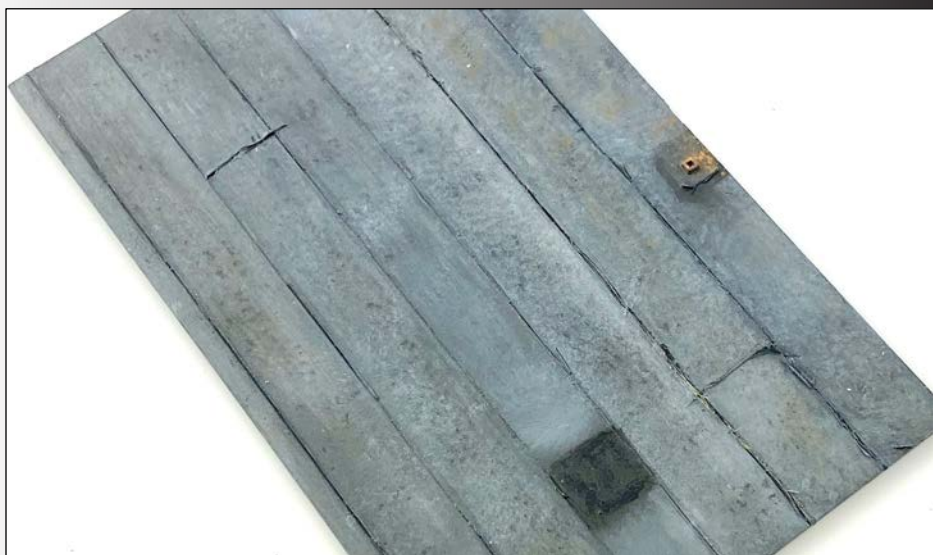

Model Railroad Hobbyist | November 2021



**GREG BAKER** SHOWS HOW TO MAKE  
CONVINCING TAR PAPER ROOFS ...

**CONTINUING THE DISCUSSION OF UPDATING AND MODIFYING PLASTIC ROOFS TO** better represent the prototype, this month we focus on tar paper roofs. I'll go through several stages of weathering to show how to represent anything from a brand-new roof to a roof in need of replacement.



Tar paper roofing has been around for centuries. Different from roofing felt, which is an underlayment for other roofing materials, tar paper is the final, top layer.

Tar paper is very common on flat roofs, but you can also find it on sloped roofs. The material can be stapled or nailed in place, though adhesives such as hot asphalt are more commonly used.

The material is sold in rolls of various width and length. The most common is 3' wide by 36' long. Like all roofing, this material requires overlap bottom-to-top and at the seams. Tar paper is laid starting at the bottom and working up so the water can run down and not get trapped between layers.

For a flat roof, roofers work from side-to-side, overlapping enough material to prevent it lifting in rain and wind. Remembering this helps modeling tar paper in a believable manner.



**1. Left-to-right: Sloped roof needing replacement, mid-life, and nearly new.**





2. Left-to-right: Flat roof nearly new, medium-aged, needing replacement. Note the patched areas where the aging roof has been repaired.

## SLOPED ROOFS



3. Roofing material from a Walthers kit is very clearly plastic.



4. My first step is to use a sharp #11 blade and sandpaper to clean off burrs and eliminate casting marks. Then I work along the edge and cut small notches at the top of each run to disrupt the perfectly straight edges.



5. I use the knife to cut nicks and dings along the bottom edge of the roof to add character.





6. The lack of texture is a giveaway that the roof is plastic. sanding to work with the grain enhances the look and adds tooth for painting. This sanding stick from Excel has a replaceable belt and is one of my favorite tools.

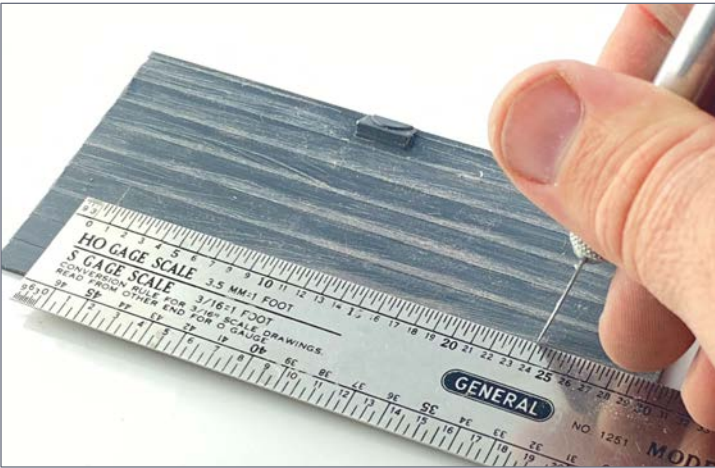

7. Since rolls are 36' long, I start at the bottom with a scale ruler and make marks every 30' to represent material overlap. I then scribe a line at each mark to represent seams. A newer roof is ready for painting after this step.



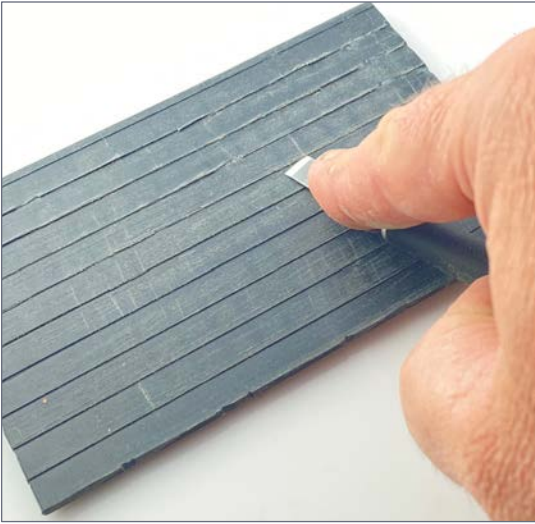

8. If I am going for an older roof, I use a flat blade to lift, stress, and cut the plastic along the bottom edges, to give the appearance of a tar paper roof that is starting to fail. Don't place your hand in front of the blade, as it can slip.



9. Ready for the next step. The upper roof is new and the lower roof needs repair.



[REGISTER](#)  
*(free)*

[INDEX](#)

[TABLE OF CONTENTS](#)



10. The new roof. I add a coat of flat black spray paint to the plastic, spraying at a good distance. I lay the roof panels on the ground and allow the paint to fall onto the plastic. Spotty coverage, rather than even, is good to represent texture.



11. I followed the same procedure as [10] on this derelict roof.



12. I brush-in weathering and color using Tamiya Gloss Black and Vallejo Flat Earth, White, and Black.



13. Left-to-right: I use a 6 Flat, a 6 Round, and a 20/0 round brush to add weathering.



**REGISTER**  
(free)

[INDEX](#)

[TABLE OF CONTENTS](#)



14. I use the flat brushes to apply a wash of Flat Earth paint and water to provide a base coat and blend the colors. I use very little paint for a new roof (left). I increase the mix to almost 50:50 for an older roof (right).



15. I use a broad brush to apply a wash, working from top-to-bottom. Leaving the water to dry on a flat surface creates a nice base coat of weathering.





16. When the brown wash is dry, I decide how old the roof is going to be. Asphalt roofs tend to fade from black to gray, getting lighter and more worn as they age. For the newer section of roof, I used a wash of Vallejo black and water. For older roofs, I mix in white to create various shades of gray.



17. This represents a much older roof, so I used almost a 50:50 mix of water and gray paint. I work from top-to-bottom for a streaked look.





18. For a newer or less-weathered roof, I use a 00 brush and Tamiya Gloss black to paint along the seam lines to represent sealing. This is not necessary on all roofs, but it adds a bit of color and depth.



19. The final step is to dry-brush the model. I use all the colors to add variation to the roof. For the newer roof, I use mostly black, then add some light gray for the medium-aged portion.



20. For the aged roof, I dry-brush mostly light gray and brown.

After dry-brushing, these roofs are ready for installation. You can add other details such as rust streaks from metal vents, bird droppings, patches, and repairs.

## FLAT ROOFS

Although the material is the same, the installation is different, mainly in that the rolls overlap less than on a sloped roof. Each joint has a generous amount of sealing tar. I developed some techniques to capture this look.

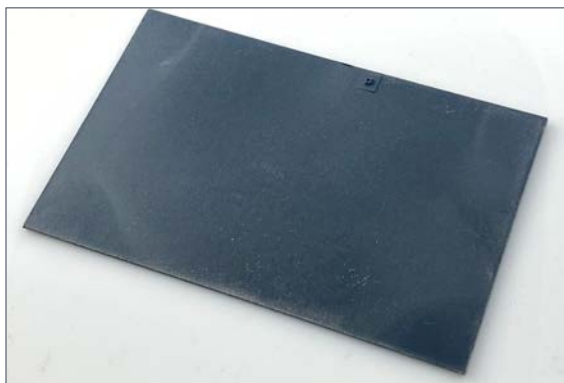

21. This out-of-the-box older roof from a Walthers kit have some texture and a spot for a smokestack, but lack seam lines.





22. I begin by adding seam lines. Most rolls are about 36" wide and are laid with a few inches of overlap. To simplify, I scribe lines 3' apart using a scale ruler and a #11 blade.



23. Most rolls are around 100' long, so I measure along the horizontal and scribe seams to represent the transition from one roll to the next. Then I dust the roof with flat black spray paint. As with the sloped roof, the aim is for a spattered look.



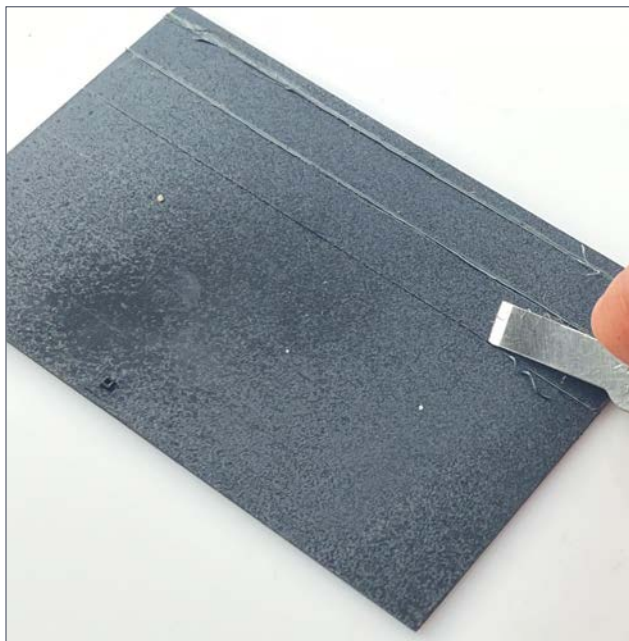

24. To model a roof that is in need of repair I push a #17 flat blade along the scribed horizontal line to create a 'V' groove. For added effect I then place the tip of the blade in the groove and lift.



25. I use the Tamiya Gloss black and a 20/0 brush to paint along the seams to represent tar sealing lines. I load the brush with enough paint so it creates some blobs and unevenness. Tar seams are never perfect in real life.





26. Some patches, tar splotches, and other details to add to the look. I added Vallejo black over the seam lines on the older roof at left to weather the black.



27. I use a wash of earth brown and water as a base for further weathering, and to dull the gloss paint. I go very lightly with the brown on a newer roof (left) and heavier for an older roof.



28. I apply gray wash using horizontal strokes with a wide flat brush to represent aging. The lower portion has no gray wash to represent a practically new roof.



29. I use the same gray wash for an older roof, then use a round brush to dab flat earth on some locations to represent dirt and grime.

★ ★ ★ ★ ★  
**RATE THIS ARTICLE**



**REGISTER**  
*(free)*

[INDEX](#)

[TABLE OF CONTENTS](#)

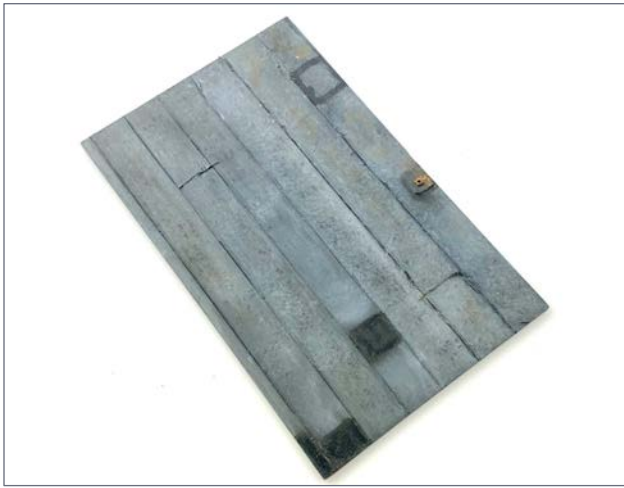

30. With just a few more details, the roof looks old and worn out. Playing around with these techniques can create some great variety and really add to the overall look of a building.

## GREG BAKER



Greg Baker has been “seriously” model railroading since 2000, but as long as he can remember he has always been fascinated by trains. Greg’s main interest is the Spokane Portland & Seattle Railway and its operations in Oregon in the late 1960s. He enjoys the operations along the Oregon Trunk, but has recently started a modeling project

based on Astoria, Oregon.

Greg lives in the Portland, Oregon area, and has started a job with a local transit agency there. He is excited to be back in Oregon and to enjoy everything it has to offer, while spending time with his wife and two kids. He is currently working on remodeling his garage into a workshop and layout room. ■



# Penny wise and pound foolish with your hobby?

## SPECIAL DEAL:

Subscribe now and get the next 12 issues plus **ALL 34 BACK ISSUES!**

Every copy of MRH's Running Extra has tricks that can save you hundreds of dollars and hundreds of hours ...

~250 pages, \$2.99 ea.

**1 year sub: \$29.99** next 12-issues (\$19.99) + all 33 back issues (\$10)

*You can buy and download single issues or get a 12-issue subscription (\$19.99) and get all back issues for just \$10 more!*

~100 pages of all-meat in-depth articles and columns + all the free MRH pages ... one download gets it all!

**Get MRH  
Running Extra**

[click here](#)



270+ pgs ... as a paperback, would be 3/4" thick -- for just \$2.99!

Paper mags: ~8 cents per page  
Running Extra: ~1 cent per page!



**REGISTER**  
(free)

[INDEX](#)

[TABLE OF CONTENTS](#)

# SAVVY MODELER *Online*



RATE THIS ARTICLE

Model Railroad Hobbyist | November 2021



## Fir/pine tree modeling

Grant Eastman shows how to make some great looking scale fir/pine trees on his **Southern Alberta Rail** channel. Follow along with this 7 minute video to learn how easy making great looking conifer trees can be. While Grant's trees are N scale, his methods work for any scale from Z to O.

This step-by-step how-to video shows you the entire process and how easy great looking conifer trees can be to make!



▶ GREAT MODELER VIDEOS ON THE WORLD WIDE WEB

**The 2022 show is on!**



# The Amherst Railway Society Railroad Hobby Show

## January 29 & 30, 2022

Save the dates!

**Click  
to learn  
more ...**



**REGISTER**  
*(free)*

[INDEX](#)

[TABLE OF CONTENTS](#)



# NOVEMBER NEWS

column



Model Railroad Hobbyist | November 2021

**RICHARD BALE AND JEFF SHULTZ**  
REPORT THE LATEST HOBBY  
INDUSTRY NEWS ...



## NEW PRODUCTS FOR MULTIPLE SCALES



**Broadway Limited Inc (BLI)** has posted a video on YouTube showing the new PRR I1sa and Milwaukee Road S3 in HO scale and the USRA 2-8-2 Mikado in N scale. Also included was a sneak peak of a test sample PRR E-6 4-4-2 Atlantic. Click on the info link to view the video.

Info: [youtu.be/gCqNqn4Qu00](https://youtu.be/gCqNqn4Qu00)

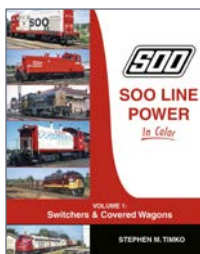
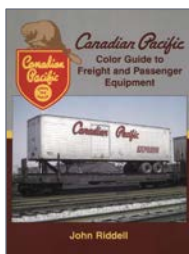

**Morning Sun Books** has published a digital reprint of *Canadian Pacific Color Guide to Freight and Passenger Equipment*. Author John Riddell provides a comprehensive examination of the rolling stock on this trans-

THE LATEST MODEL RAILROAD PRODUCTS, NEWS & EVENTS



continental system, focusing on the 1950s -1970s era.

Morning Sun has also released *Soo Line Power In Color, Volume 1: Switchers & Covered Wagons*, by Stephen M. Timko. This initial volume of MStP&SSM power offers 300 color photos of Soo Alco, EMC, EMD, Baldwin, Fairbanks-Morse diesels, plus one lone GE unit.

Info: [www.morningsunbooks.com](http://www.morningsunbooks.com)



**Motrak Models** has introduced two new Workstations. Measuring 10-1/2" long x 6-1/2" deep x 4-3/4" tall, the workstation kits are constructed of Masonite hardboard. The Vallejo Workstation holds 22 Vallejo/MIG/AK eye dropper (17ml) bottles, and the Paint Workstation provides a 1"

deep open area for storing assorted paint bottles. The workstation also includes two rows of drawers. The top row has two drawers that are 2-3/4" deep, and the bottom row is split into four drawers that are 6-1/4" deep. Two of the bottom drawers are 3" wide and the other two are 1-7/8" wide. There are holes for mounting the workstation on the wall.

Info: [motrakmodelsusa.com](http://motrakmodelsusa.com)

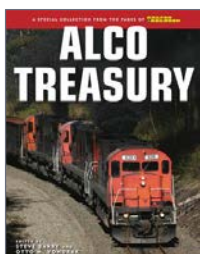
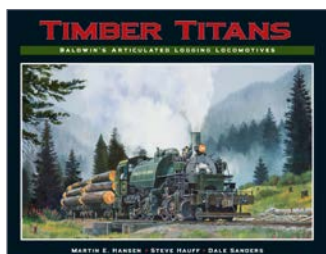

**White River Productions** has released the second printing of *Timber Titans: Baldwin's Articulated Logging*

*Locomotives*. This new 256-page hardcover edition by Martin



REGISTER  
(free)

[INDEX](#)

[TABLE OF CONTENTS](#)

E. Hansen, Steve Hauff, and Dale Sanders presents these fascinating logging locomotives in construction order and great detail with statistics and full histories that document each locomotive from the day it left Baldwin's Eddystone, PA factory to its ultimate disposition.

Also new from White River is *Alco Treasury*, a comprehensive collection of stories about the American Locomotive Company diesels and the railroads that used them. The 96 page softcover book presents the best of Alco articles from the pages of *Railfan & Railroad Magazine*. Both books are available now from dealers.

---

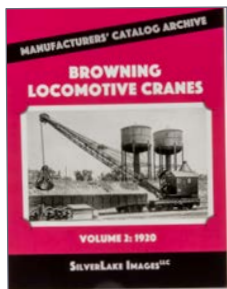

**Silver Lake Images** has published a reproduction of a *Browning Locomotive Cranes* catalog from 1920. The 52 page softcover book includes descriptions of cranes, their components, and photos of cranes being used in a variety of industries.

Info: [ronsbooks.com](http://ronsbooks.com)

---

## 0 SCALE PRODUCT NEWS

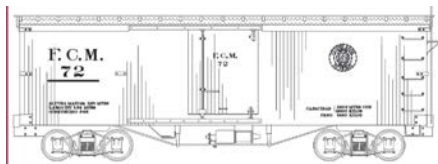

**Leadville Designs** has introduced a kit for a 30' FCM (Ferrocarril Mexicano) boxcar. The On30 scale craftsman-style kit includes laser-cut wood

body components and an arched roof of corrugated tin. Additional parts include injection molded plastic, 3D-printed, and etched brass details. Suitable decals are included. Trucks and couplers are not included.

Info: [leadvilledesigns.com](http://leadvilledesigns.com)

---

## S SCALE PRODUCT NEWS



**Pre-Size Model Specialties** has issued a new S scale kit for a 50' Southern Pacific class A-50-6 single-sheathed door-and-a-half automobile car. The model is based on a prototype built in 1923 that served well into the 1950s. The kit features a one-

piece detailed resin body with Z bracing and a separate floor/underframe. The kit includes 3D printed details, wire grab irons, wood running boards, full brake rigging and correct decals. Trucks and couplers are not included.

Info: [www.pre-size.com](http://www.pre-size.com)

## HO SCALE PRODUCT NEWS



New easy to assemble HO scale kits from **Accurail** include this 50' steel boxcar with offset double plug-

doors. The car wears a Wisconsin & Southern TP&W paint patch. The model is based on a Plate C prototype built in June 1971.

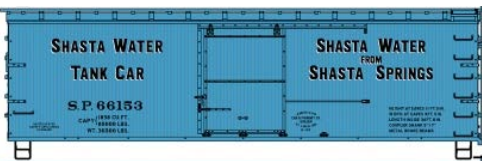

Accurail has released a 3-car pack of 36' Southern Pacific double-sheathed wood boxcars specially decorated for Shasta Water. The kit was inspired by a prototype built by American Car & Foundry.



This 36' Canadian Pacific single-sheathed wood boxcar is based on a Fowler prototype.



**REGISTER**  
(free)

[INDEX](#)

[TABLE OF CONTENTS](#)



Also new from Accurail is this BNSF triple-bay covered hopper.

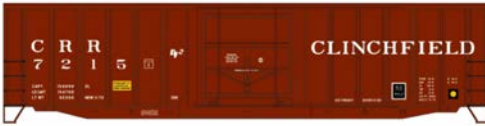

This 50' welded steel boxcar with exterior posts and a plug door from Accurail is based on a car

built for the Clinchfield Railroad in November 1973.



The HO scale kit for this Burlington Northern twin-bay ACF Center Flow covered hopper is available now from Accurail.



Accurail's December/January production schedule includes a 3-car set of this Rock Island triple-bay Center

Flow covered hopper with a Milwaukee Road patch. All Accurail HO scale freight car kits come with Accumate couplers and appropriate trucks with Delrin wheelsets.

Info: [www.accurail.com](http://www.accurail.com).

in the **NOVEMBER 2021 MRH RUNNING EXTRA!**

**Did you see this article?**



**Scratchbuild a backwoods mill**

**Get this eBook now ▶** ← click here

Each eBook ~100 pages

**MRH RUNNING EXTRA**







R. Bale

## EMD SD60M DIESEL LOCOMOTIVE

EMD introduced the SD60 in the summer of 1984. The clean lines of the huge body were similar to its SD50 predecessor. Most of the changes were internal, including a new V16 3,800hp prime mover, wheel slip control, and microprocessor controls. Production continued through 1991 with nearly 600 SD60s purchased by American railroads. Five years later, EMD began offering the SD60 with the wide nose safety cab with a 3-piece windshield that earned the newly designated SD60M the nickname Tri-Clops. Union Pacific was the first road to order these new SD60M locomotives followed by Burlington Northern and SOO Line. BN's SD60M locomotives went on to the merged BNSF while the SOO Line units went to Canadian Pacific. Some of the BNSF units turned more mileage with Norfolk Southern and in lease service for CEFX.



An Athearn Genesis version of an EMD SD60M

diesel is scheduled for release in December 2022 in five road names. Nicknamed 'Tri-Clops' for the 3-piece windshield, road names for Athearn's HO scale SD60M include Union Pacific with pilot mounted ditch light and a large plow.



Soo Line/  
Canadian Pacific  
units will come  
with a large

EMD plow, winterization hatches and a roof mounted strobe light.

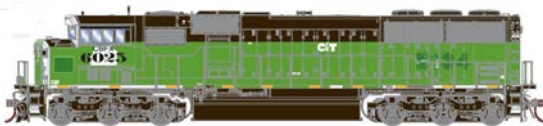

Genesis SD60M  
units decorated  
for CIT Group  
will have a



REGISTER  
*(free)*

[INDEX](#)

[TABLE OF CONTENTS](#)

small EMD plow and deck mounted ditch lights. Three numbers will be available with variations in the patched paint scheme including Primed for Grime.



BNSF units will also have a small EMD plow, and both

front and rear deck mounted ditch lights.



Ex-Union Pacific SD60M units acquired by Webb Asset

Management come with a large plow. They retain the UP flag and winged nose art in a Primed for Grime scheme.



R. Bale

## EMD SD59M-2 DIESEL LOCOMOTIVE

Beginning in 2012, Union Pacific returned 28 SD60M diesel locomotives to EMD for rebuilding that included replacing the existing V16 prime mover with a 710G3B-T2 turbocharged V12 with electronic fuel injection. The UP SD60M car bodies retained many of the original components and subassemblies, having them recycled and recertified as equal to new. EMD also installed a new control system that is adaptable to both minimum emissions and minimum fuel consumption modes, depending upon the specific locomotives assignment. The rebuilt units were designated SD59M-2.



Athearn has announced plans to release an HO scale SD59M-2 in

December 2022. Spotting features of the new Genesis model include a newly built flared radiator section, a new 4500-gallon

safety fuel tank, and a windowless nose door. In addition to the flag scheme shown, two road numbers of the Union Pacific locomotive will be available with lightning stripe and a nose shield with wings.

Athearn Genesis locomotives, including the SD59M-2 and SD60M listed in this report, come with LED lighting, coupler cut levers, MU hoses, trainline hose, see-through cab windows, cab interior details, walkway tread, windshield wipers, wire grab irons, sander lines, see-through steps, Celcon handrails, and fuel tanks detailed with fillers, gauges, and breather pipes. The Genesis all-wheel drive utilizes a 5-pole skew wound motor with machined flywheels. DCC sound equipped models come with SoundTraxx Tsunami2 sound.



R. Bale

## EMD SD40-2 DIESEL LOCOMOTIVE

The SD40-2 was one of EMD's most popular locomotives. During its 17 year production run that began in 1972, EMD produced nearly 4,000 of the 3,000hp SD40-2s. Although higher-horsepower locomotives were available, the reliability and versatility of the SD40-2 made it one of the best-selling models in EMD's history. The SD40-2s principal improvement over the SD40 was its modular electronic control systems. A variety of low front noses ranging from 81" to 123" in length housed additional electronic gear along with a more commodious toilet for crew members.



Athearn has included an EMD SD40-2 diesel unit in its

December 2022 production schedule. The Ready-to-Roll HO scale model is based on the best-selling prototype produced by



**REGISTER**  
(free)

[INDEX](#)

[TABLE OF CONTENTS](#)

EMD in the 1970s. Six road names will be available in this release including ex-Southern high-hood units decorated for Norfolk Southern with the locomotive set up for operation with the long hood forward.



Features unique to Santa Fe SD40-2s include an air conditioner on the cab roof and the headlight moved from the cab to the nose with the original location plated over.



Athearn reports that the colors and art work on its B&O SD40-2 diesel

locomotive have been upgraded and approved by concerned Chessie System experts.



Athearn's KCS version of the SD40-2 will have a nose mounted gyalight, front and rear ditch lights, and a Chessie style rock plow.



An ex- Milwaukee Road SD40-2 decorated for EMD Lease (not a demo) will have a

short fuel tank. The model will come with two different styles of plows in a poly bag for installation by the modeler.



Completing this December 2022 release of RTR SD40-2s

is a Union Pacific version with a cab mounted strobe light, a large snow plow and post-1984 grey trucks. All Athearn SD40-2 road names will be available with Tsunami2 Sound with dual



cube speakers. The models will also be available for standard DC operation with a Quick Plug 21-pin NEM connector for installation of an aftermarket decoder.



Athearn plans to release its HO scale 20,900 gallon 51' general service tank car in December 2022. The Ready-to-Roll model should be well-

received since it has not been available new since the summer of 2015. The HO scale car is an accurate model of the prototype built by Richmond Tank Car in the 1960s.



Decorating schemes will include PEMEX (placarded for gas, oil or diesel fuel), TLDX (dicyclopentadiene), Santa Fe (flammable liquids), CELX

(ethyl acetate), and Burlington Northern Santa Fe (flammable liquids). The model comes with 100-ton roller-bearing trucks with 36" metal wheelsets.



Also coming from Athearn at the end of 2022 is a 60' Gunderson high-cube boxcar with double plug doors. Road names will be

RailNet, Providence & Worcester, Norfolk Southern, Southern Pacific, and two TTX schemes.

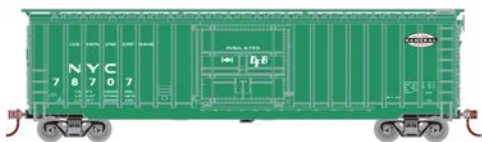

**Roundhouse** brand models in Athearn's Dec 2022 production schedule include a 50' outside braced plug door boxcar with 70-ton roller-

bearing trucks with 33" machined metal wheelsets.



Road names announced for this release are Santa Fe, Burlington Northern, Chessie

System, Reading, Lehigh Valley, and New York Central. Athearn has included a car decorated for Hobbies for Good, and has pledged to make a donation to the charitable organization for each model purchased.



A Roundhouse 30' flatcar completes Athearn's December 2022

production schedule. In addition to the Maintenance of Way scheme shown, the HO scale model will be available decorated for Denver & Rio Grande Western, New York Central, Southern Pacific, and New Haven. A Pacific Electric version with side rails will also be included. All of the Athearn and Roundhouse brand freight cars mentioned in this report will come with McHenry knuckle couplers and appropriate trucks with machined metal wheels.

Info: [www.athearn.com](http://www.athearn.com).

---



R. Bale

## ALCO HH600/660 SWITCHER

Between 1931 and 1940 the American Locomotive Co (Alco) built 177 high hood (HH) switching locomotives with horsepower ratings ranging from 600 to 1000hp.

The 600/660hp units represented more than half of the nine year production run. Various physical changes occurred during the extended period of production including a major change in 1934 when industrial designer Otto Kuhler improved the appearance of the boxy, utilitarian switchers. All of Alco's HH600 660 series locomotives were delivered with Alco's own Blunt trucks which were specifically designed to handle the rough, uneven secondary track often found in industrial switching areas.





**Atlas** plans to deliver an Alco HH600/660 diesel switch engine during the third quarter of next year.



The HO scale model will be produced from new tooling and will be equipped with Blunt trucks with separate brake cylinders, molded coil spring detail, and metal truck chains.



Additional details include separately applied metal grab irons, lift rings, stanchions, handrails, and coupler cut levers.

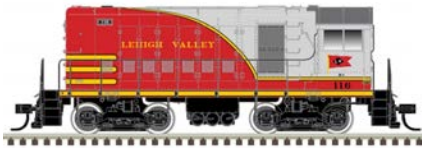

Road names will be Erie Lackawanna, Jersey Central, Lehigh Valley, New Haven (McGinnis scheme), Railco, Santa Fe, and two Southern Pacific

schemes. Both DC and DCC versions will be available.



Heading the list of new HO scale freight cars coming from Atlas during the third quarter of 2022 is a newly tooled Master series Trinity 3230 cu. ft. pressure

differential covered hopper. The cars smaller size enabled it to be loaded with heavier ladings such as cement.



Details on the Master series model include separately applied wire grab irons and cut levers, and etched metal roofwalks.



**REGISTER**  
*(free)*

[INDEX](#)

[TABLE OF CONTENTS](#)



and CLSX- Cargill Salt.

Road names on this run will be BNBX-Greenbrier Management Services, GACX-General American, CBFX-CIT Group, LAFX LaFarge North America,



Atlas has included a classic 40' AAR standard postwar boxcar in its 2022 third quarter production schedule.



roof, and either 4/4 corrugated, Dreadnaught, Improved Dreadnaught or Dartnot ends.

The HO scale Atlas Master series model will have 8' Youngstown or Superior sliding doors. Additional variations include



Road names on this run will be Detroit & Mackinac, Erie, Kansas City Southern, Maine Central, Pennsylvania Railroad, and Canadian National.



car Thrall designed in the late 1970s, primarily for grain transport.

New paint schemes and road numbers will soon be available for this Atlas triple-bay covered hopper. The Trainman series model is based on a 4750 cu. ft.



to run model decorated for Union Equity, BNSF (with conspicuity stripes), CATX, David J. Joseph Transportation,

Atlas will offer the HO scale ready



Midwest Railcar (ex-Rock), Minneapolis, Northfield & Southern, and EAFX-Rail Logistics.



Atlas has included a Trainman series HO scale 52' Evans gondola in its 2022 third quarter production schedule.



Road names include GE Railcar Services, Maine Central, Bangor & Aroostook, Chicago West Pullman, Illinois Central Gulf, JOBX, MHF Logistic Solutions, and Bethlehem Steel.



All of the Atlas freight cars in this report will come with metal wheelsets and

Accumate couplers.

Info: [www.atlasrr.com](http://www.atlasrr.com)

---



**Bachmann Trains** has released models of EMD's iconic FT-A locomotive in HO scale. Road names in this release include Santa

Fe, New York Central, Lackawanna, Southern, and Western Pacific. The models feature a can motor, all-wheel drive, RP25 wheel contours, and E-Z Mate Mark II couplers.

This run introduces TCS Sound Value DCC, which includes a



prototypical horn, bell, and prime mover sounds, usable on both DCC and DC layouts. The locomotive is also equipped with a Keep-Alive

capacitor device to ensure continuous power even on dirty track or short sections of track that do not carry power.

Info: [bachmanntrains.com](http://bachmanntrains.com)

---



**REGISTER**  
(free)

**INDEX**

**TABLE OF CONTENTS**



**Cannon & Co.** is selling a parts kit for an HO scale model of a Berwick Foundry & Forge Plate C boxcar with a 10' plug door. The model is based on a

prototype built in 1970 with a 50' 8" interior length, a capacity of 5260 cu. ft., and 20" Keystone cushioning. The craftsman style kit (Item B-5010) includes both outer and inner sides, rib and hat sections, Plate C ends, door hardware and details sheet. Additional parts are to be supplied by the modeler.

Info: [shop.cannonandco.net](http://shop.cannonandco.net)

---



**The Chesapeake & Ohio Historical Society** has several 3D-printed car sides that experienced modelers can use to build

prototypically correct cars by applying the sides to

donor passenger models such as Walthers, Bethlehem Car Works, Athearn, and others. 3D sides are available now for C&O series 413-420 wood combine car (above) and a heavyweight express horse car (below).



Car sides are also available for a modernized horse car, a heavyweight RPO-express car, and a coach with wood sides.

Info: [chessishop.com](http://chessishop.com)

---





**Conowingo Models** has introduced a 24' tool car. Featuring board-on-board construction and an all-wood floor. Trucks and couplers are available as an option, with both Tichy and Kadee arch bar trucks available with Kadee #148 couplers. Info: [conowingomodels.com](http://conowingomodels.com)



including Route of the Hiawatha and Electrified Olympian.



**ExactRail** has completed another release of its HO scale Milwaukee Road rib side boxcars. Four as-delivered paint schemes are available with various slogans

Additional schemes include a 1963 repaint with the famous angled logo, and a car decorated for the Chicago, Terre Haute & Southeastern, a regional coal line controlled by CMStP&P.



The HO scale Platinum series ready-to-run model features 5/5 Dreadnaught ends, Youngstown sliding doors, Kadee #58 couplers, wire uncoupling levers, and 50-ton Barber S-2 plain-bearing trucks with machined metal wheelsets. Info: [www.exactrail.com](http://www.exactrail.com)

★★★★★  
**RATE THIS ARTICLE**



R. Bale

## COALPORTER GONDOLAS

Unit trains of specially designed gondolas began to replace conventional coal carrying hopper cars in the 1970s. The new gondola design replaced moving hopper doors and high-maintenance locking mechanisms with long tubs on either side of the cars center sill. Eliminating the hopper outlets provided additional coal-carrying capacity in a car of the same length. One of the most popular of the modern coal gondolas is Johnstown-America's BethGon Coalporter. In production since 1978, these cars are distinguished by their angled end slope sheets and two lengthwise tubs below the frame levels. Gondola cars dedicated to coal hauling have rotary couplers allowing them to be emptied by a rotary car dumper.

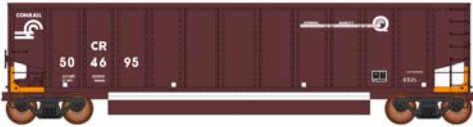

**InterMountain** plans to release both 13- and 14-panel Coalporters by December 1st. Road names

for the HO scale 13-panel cars will be New York Central, two CSXT cars, and four Conrail schemes.

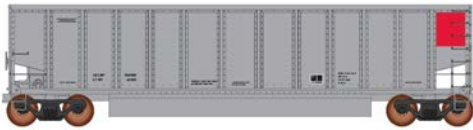

Three data only cars with red, yellow, and blue end panels are included in the 13-panel group.



Eleven road names will be available for Coalporters with 14 side panels.



They include BNSF, SULX-Sultran, FPPX- Fayette Power, Canadian National, HIPX-Houston Lighting &

Power, TGNX-NRG Energy, WFX-Western Fuels, Conrail, GSNX-Gulf States Utilities, JECX-Jeffrey Energy Center, and WEPX-Wisconsin Electric Power.



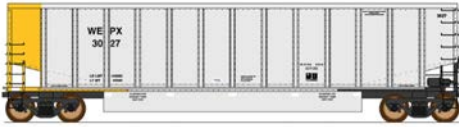

Info: [www.intermountain-railway.com](http://www.intermountain-railway.com)

---



The latest release from **Kadee** is a 40' PS-1 boxcar decorated for the Southern Railway. The HO scale model is based on a prototype Pullman-Standard built in 1948 with P-S ends and Superior 7-panel sliding doors. The ready-to-run model comes with Kadee metal couplers and self-centering Bettendorf -type plain-bearing trucks with metal wheels.

Info: [www.kadee.com](http://www.kadee.com)

---



**Kato USA** is anticipating a March 2022 release date for three HO scale GE P42 locomotives

decorated in Amtrak's 50th Anniversary paint schemes.



Featuring Kato's coreless truck-motor drive system, the models will be available in both DC and DCC/Sound versions.



The paint schemes being offered are the 50th Anniversary Phase V paint, the 50th Anniversary Midnight Blue paint, and

the 50th Anniversary Phase I paint.

Info: [katousa.com](http://katousa.com)

---



REGISTER  
(free)

[INDEX](#)

[TABLE OF CONTENTS](#)



**Maple Leaf Trains** has introduced a kit for an HO scale GP9RM with covered classification light housing. As with other GP9 kits from Maple Leaf this GP9RM version includes numerous 3D printed detail parts, formed wire parts, etched metal windshield wipers, steps, stanchions, and grilles.

Info: [www.mapleleaftrains.com](http://www.mapleleaftrains.com)

---



**Micro-Mark** has developed unique pliers that spread plastic truck frames, making it easy to remove or replace wheel sets. The specialized tool is available for HO standard gauge trucks only.

Info: [www.micromark.com](http://www.micromark.com)

---



**National Scale Car** has introduced a craftsman-type mini-kit to build an HO scale Baltimore & Ohio class M55 1937 ARR standard 40' boxcar.

The kit replicates cars built by Pressed Steel Car and Pullman-Standard to the 1937 design with car builder ends, flat seam roofs with interior carlines, and Duryea under frames. Kits are available with a choice of Pressed Steel or Pullman-Standard car ends. There is also a choice of underframes.

The mini-kit includes all of the components needed to rebuild a donor car into a prototypically accurate model of a B&O 40' class M55, M55A, or M55B 1937 ARR boxcar. Donor cars, to be supplied by the modeler, can be InterMountain, Red Caboose, or



IMWX 40' boxcars with a 10' IH and 6' doors.

Info: [www.nationalscalecar.com](http://www.nationalscalecar.com)



R. Bale

## HAWKER-SIDDELEY TEMPO COACHES

In 1968, Canadian National introduced Tempo – a modern, aluminum, head end power (HEP) equipped passenger fleet built by Hawker-Siddeley. The new cars were assigned to service in Southwestern Ontario. After ten years of service, the fleet was transferred to VIA Rail Canada and in 1983, the Tempo coaches were converted from 575V to 480V so they could be hauled by VIA's LRC and Amtrak's F40 locomotives, frequently on the International between Toronto and Chicago. With the loss of cafe-bar-lounge cars on several routes in the early 1980s, VIA Rail converted six Tempo coaches to snack coaches. The conversion altered the arrangement of windows on the VIA cars.



**Rapido Trains** has announced a special limited run of VIA Rail Tempo snack coaches. The HO scale cars replicate

half a dozen coaches VIA converted to snack coaches in 1983. Rapido's product development team scaled the model from blueprints and field measurements.

Features include full, multi-color interiors with individually-installed seats, track-powered interior lighting and working marker lights, etched-metal end gates, complete underbody



REGISTER  
(free)

[INDEX](#)

[TABLE OF CONTENTS](#)



details with separate piping and conduit, and trucks with ball bearing wheelsets. Info: [www.rapidotrains.com](http://www.rapidotrains.com)

---



**Sylvan Scale Models** is booking reservations for an HO scale 57' Canadian National double deck automobile transporter. The model is based on 75 cars

delivered to CN in 1959. Subject to the receipt of sufficient orders, the HO scale kits will be produced in four variations including the as-delivered CNR maple leaf scheme, above.



Additional schemes include the all-blue CN noodle Car-Go-Rail service from early 1960's, and CN's black and white passenger service scheme.

Eight of the prototypes were used in automobile transportation service on CN's Super Continental passenger train in the 1960's and 1970's. Later in their careers, some cars were converted to handle boats and roof trusses. One was turned into a cattle car. Each kit comes with the appropriate decals. The kits are unassembled and unpainted and do not include trucks or couplers.

Instructions on how to build these kits is available at [hubdayrailway.blogspot.com/2021/10/cn-auto-transporter-build.html](http://hubdayrailway.blogspot.com/2021/10/cn-auto-transporter-build.html)

---

**Tangent** has completed the fourth production release of its 86' Greenville double door boxcars. The well-executed model





is an accurate HO scale replica of the prototype auto parts cars built by Greenville during the 1960s.



Several of the road names have unpainted aluminum doors. All versions come with Kadee couplers and machined metal wheelsets.



Road names include Santa Fe Bx-106 and Norfolk Southern B20 which both come with 70-ton Barber S-2A trucks.



The Union Pacific BF-90-5 version of the car rides on 100-ton Barber low-profile S-2-C trucks with Hyatt roller-bearing caps.



A spotting feature on the Conrail car is the Morton cross over platform.



**REGISTER**  
(free)

[INDEX](#)

[TABLE OF CONTENTS](#)



Additional road names available now include Illinois Central Gulf, Pennsylvania Railroad, and

Southern Pacific. Due to the car's extended length, Tangent recommends track curves of 24" or larger for these models. Info: [www.tangentscalemodels.com](http://www.tangentscalemodels.com)

---



**Walthers** has scheduled another production run of its Proto series EMD F7 diesels with delivery planned for April 2022. Both F7A and matching

F7A/B sets will be available in standard DC and with LokSound 5 Sound and DCC. Units decorated for Baltimore & Ohio and Great Northern will have a single headlight at the top of the familiar Bulldog nose.



F7A units decorated for Chicago & North Western and Southern Pacific will have a second headlight in the nose door.



Air horns, antenna systems, and pilots will be road specific. All versions will have Farr side grilles.



Walthers has scheduled a January release date for a new run of its Proto series 85' Pullman-Standard Bi-Level

commuter coaches and cab coaches. The HO scale models will feature authentic window tinting and sprung operating diaphragms. For the first time Walthers commuter cars will be available with optional LED interior lighting.



Coaches and cab coaches will be available decorated for Chicago & North Western. The

coach will also be available for Southern Pacific.



R. Bale

## EMD NW2 DIESEL SWITCHER

Electro Motive Corporation introduced the NW2 diesel switch engine in late 1939. With a rating of 1,000hp, the NW2 was considered quite powerful for a locomotive that weighed only 124 tons and was just a little over 44' in length. EMC, and subsequently EMD, built 1145 of the popular NW2 before production ended in 1949. More than 50 North American railroads purchased the popular switcher. Many NW2s, readily identified by their dual conical exhaust stack, are still in service on short lines, light industrial applications, and tourist lines.

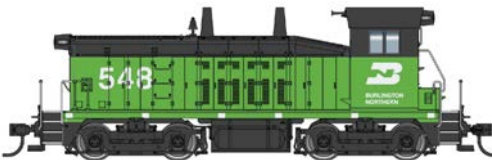

Walthers plans to release a group of EMD NW2 switch engines in February. The versatile diesel was one of EMD's biggest successes

with more than 1,100 built. Walthers Mainline series HO scale



[REGISTER](#)  
(free)

[INDEX](#)

[TABLE OF CONTENTS](#)

model is based on Phase V units built in 1949. Spotting features include a louvered radiator grille, dual tall conical exhaust stacks, large center cab windows, and six louvered side doors with a letter board gap.



Road names will be Burlington Northern, Chesapeake & Ohio, Erie Lackawanna, Great Northern, Lehigh Valley, and Southern Pacific.



Walthers EMD NW2 switch engines will be available for standard DC operation and with ESU Sound and DCC.



Also coming from Walthers in Feb-

ruary are 85' General American G85 flatcars. The HO scale models will come with GATC hitches in both up and down positions, or with container pedestals as appropriate to the car being modeled.



Features of the Mainline model include a heavy diecast metal center sill, and 70-ton roller-bearing trucks. A minimum track radius of 24" is recommended.



Road names will be Erie Lackawanna, Pacific Fruit Express, Railway Express

Agency, Union Pacific, VTTX, TTX-Trailer-Train, and two GTX-Trailer-Train (brown and yellow) cars.







A new series of 50' 100-ton quadruple-bay coal hoppers have been released to Walthers dealers this month. Walthers was influenced in the design of this HO scale Mainline model by unit cars that served the Powder River Basin coal mine.



Road names in this release are Burlington Northern, CSX, Chicago & North Western, Norfolk Southern, Denver & Rio Grande Western, and Conrail. All Walthers models mentioned in this report come equipped with Proto MAX compatible metal knuckle couplers.

Info: [www.walthers.com](http://www.walthers.com)

---

## N SCALE PRODUCT NEWS



**Athearn** plans to release an N scale 20,900 gallon 51' general service tank car in December 2022. The model should be well-received since it has not been available new since the spring of 2016. The N scale car is based on a prototype built by Richmond Tank Car in the 1960s.



Decorating schemes will include PEMEX (placarded for gas, oil or diesel fuel), TLDX (dicyclopentadiene), Santa Fe (Class 3 flammable liquids), CELX (ethyl acetate), and Burlington Northern Santa Fe (Class 3 flammable liquids). The model comes with 100-ton roller-bearing trucks with 36" metal wheelsets. Info: [www.athearn.com](http://www.athearn.com)

---



REGISTER  
*(free)*

[INDEX](#)

[TABLE OF CONTENTS](#)



Master series model is based on a 1,500hp prototype EMD built in 1952-1953.

Atlas' 2022 third quarter production schedule includes a group of N scale SD7 and SD9 diesel locomotives. The Atlas



Road names will be Chicago North Western, Baltimore & Ohio/Chessie System, and Chicago, Burlington & Quincy.

Both DCC units with sound (Atlas Gold series) and analog DC units (Atlas Silver series) will be available in this production run.



molded plastic model comes with a removable coal load.

Additional new N scale models coming from Atlas next year include a twin-bay coal hopper with offset sides. The injection



Virginia, and Norfolk Southern.

Road names will be Canadian Pacific, Chicago & Eastern Illinois, Baltimore & Ohio, Reading, Maine Central, Hallett, Pittsburgh & West



A new group of N scale tank cars fitted for transporting kaolin (clay slurry) is coming from Atlas during the third quarter of next year.



Road names will include ACFX-white over blue, ACFX white over black scheme, Dupont, Engelhard, SHPX and ACFX Thiele.



The models will come with 100-ton roller-bearing trucks.



The final N scale model on Atlas' 2022 third quarter production schedule is a 3560 cu. ft. covered hopper. The Trainman series model is based on an ACF Plate B Center Flow design with five roof hatches and three discharge outlets. Special features include roping staples and weld seams on the side sheets.



Road names will be ACFX Cancarb, Georgia Pacific, C&O Chessie System, CSX, ACFX-Kerr McGee, Potash Corporation, and Duluth, Missabe & Iron Range. All

of the Atlas N scale cars mentioned in this report will be equipped with Accumate couplers.

Info: [www.atlasrr.com](http://www.atlasrr.com)

---



**InterMountain** plans to release a group of N scale Trinity 5161 cu. ft. triple-bay covered hoppers this month. The models feature an etched metal roofwalk

and Micro-Trains trucks and couplers. Road names and a release date will be announced as soon as the container clears the port of entry.

Info: [intermountain-railway.com](http://intermountain-railway.com)

---



New N scale 40' standard height corrugated steel containers available this month from **Jacksonville**

**Terminal** include Maersk Line, K Line, Farrell Lines, YM Line, NOL Neptune Orient Lines, and a CMA CGM eco container labeled with bamboo flooring.



**REGISTER**  
(free)

[INDEX](#)

[TABLE OF CONTENTS](#)



Forty-foot Hapag-Lloyd containers are available with a choice of either the small and large blue logo.

---



Jacksonville Terminal's latest run of 17- post NSC well-cars is also available now. This release offers single packs in

two road numbers for Canadian Pacific, and two for TTX, with an additional 2- pack in TTX schemes.

Info: [www.jtcmmodeltrains.com](http://www.jtcmmodeltrains.com)

---



November 22, 2021, is the deadline for ordering one of **Kato's** E8A locomotives custom painted in the Rock Island Rocket scheme. The N scale model is being offered as part of Kato's Kobo custom line. The model will

be custom built and modified by a master modeler in Japan. Delivery is planned for February 2022. The model can be ordered with DC, DCC, or DCC plus sound, through KatoUSA or an authorized Kato hobby retailer.

Info: [www.katousa.com](http://www.katousa.com)

---



**Micro-Trains** has released an N scale model for a Chicago & North Western 70'

heavyweight baggage car. The model is based on a prototype built in 1921 that saw service on C&NW into the early 1950s.





Also released to dealers by Micro-Trains is a 4-pack of Santa Fe SFRD steel refrigerator cars with each car having a different number.



Micro-Trains based this 50' D&RGW boxcar on a prototype built by ACF in the mid-1960s with double Youngstown sliding doors.

The N scale model depicts the car after it had its ladders shortened and running board removed in 1977.

Info: Contact a dealer.

---



**Rail Smith** is accepting advance reservations for a D&RGW lightweight

baggage car decorated in the Rio Grande's distinctive four-stripe scheme. The ready-to-run N scale models are based on prototype cars that ran regularly on D&RGW's Royal Gorge and Prospector. Although not apparent in this illustration, the cars have full skirts. Delivery is planned for the first quarter of 2022.

Info: [www.lowellsmith.net](http://www.lowellsmith.net)

---



**Showcase Miniatures** has N scale kits for both standard and narrow gauge versions of a 60-ton 3-truck Class C Shay locomotive. The model is based on West Side Lumber

Company locomotive No. 12. The multi-media craftsman kit is

composed of pewter, resin and 3D printed parts. Special details include two extensive photo-etched frets. To add heft to the model, some of the parts are cold-cast with brass filled resin.



The completed kit can be operated with one or two 9 mm power trucks which may be purchased separately. To see the locomotive in operation go to:

[www.youtube.com/watch?v=4U-hDS6Fo\\_o](https://www.youtube.com/watch?v=4U-hDS6Fo_o)

## STRUCTURES & SCENIC SUPPLIES



**Atlas** reports it will release a selection of 1:160

scale Ford pickup trucks during the third quarter of 2022. The trucks will be sold in sets with one F-250 and one F-350 in each pack.



Decorating schemes will include Amtrak,

Burlington Northern, Canadian National, CSX, and Southern Pacific. The vehicles will also be available in plain white, and yellow.

Info: [www.atlasrr.com](http://www.atlasrr.com)



**Conowingo Models** is selling an HO scale kit of the Pennsbury Hydroelectric Mill. Components include Rail Scale Models cedar shake roofing, ridge beam, roof supports, rock paper, and Tichy windows and doors. The water wheel can be motorized.

Info: [conowingomodels.com](http://conowingomodels.com)



New items from **Frenchman River Model Works** include an O/On30 scale Cemetery set. The 10 tombstones, iron fence, and 10 stone fence posts are all unpainted cast resin.



Frenchman River has released the Wedge Bar. Designed by Thomas Yorke, the dilapidated HO scale corner business can serve as a bar or soda shop. The kit includes an unpainted cast resin building, plus cast cornice, meter box, and sidewalk. Decals are included.



Also new from Frenchman River is an O scale kit for Kharon Brothers Funeral Parlor.

Although Thomas Yorke designed the building to be built on a slope, the structure can easily be built for a flat surface. The kit includes numerous resin cast structure components, assorted scale lumber for the stairs, aluminum roofing material, laser-cut

window glazing, tar paper, finials, wire and signage. Two coffins are included.

Info: [frenchmanriver.com](http://frenchmanriver.com)



**Inter-Action Hobbies** has released a kit to build two rowboats in HO scale. The 15-scale-foot boat is made of laser-cut and engraved resin impregnated board, laser-cut birch

veneer, and 3D printed resin hulls. The finished models are 2" long x 4/5" wide x 1/2" high.

Info: [www.interactionhobbies.com](http://www.interactionhobbies.com)



REGISTER  
(free)

[INDEX](#)

[TABLE OF CONTENTS](#)



New 1:87 scale vehicles released by **Oxford Diecast** include this 1942 Chrysler Town & Country sedan. In addition to the wood siding the station wagon features rear fender skirts, a roof top luggage rack and wide white wall tires.



This 1948 Dodge pickup is fitted with wood side extensions.



Features on Oxford Diecast's new 1965 Ford Mustang convertible include large wheel covers and thin white wall tires.



Also new from Oxford Diecast is a 1956 Ford Thunderbird.



Completing Oxford's list of new 1:87 scale vehicles is a 1959 2-door Pontiac Bonneville coupe in Mandalay Red.

Info: [www.walthers.com](http://www.walthers.com)



**PBL Summit** has introduced an N scale storefront kit for a Lowe's Home Improvement Center. The assembled model is 12-3/4" wide by

3/4" deep. The craftsman-style kit is composed of milled white styrene plastic and laser-cut white acrylic with clear acrylic window glazing. A building-mounted sign and street sign are included along with illustrated assembly instructions. The model requires painting.

Info: [www.summit-customcuts.com](http://www.summit-customcuts.com)





**Rusty Rail** has released resin castings for an HO scale 1932 Ford 3-window coupe. Info: [www.rustyrail.com](http://www.rustyrail.com)



**Scotty's Model Shop** has two new products available. The first is a working HO scale derail. 3D-printed, the derail is hinged to allow it to either sit on the track or be

opened so that train cars can pass. Available for Code 70, 83, or 100 rail, the derail can be spiked or glued in place. Sold in packs of two, the derails come unpainted. The pictured code 70 derail is installed on Tom Klimoski's Georgia Northeastern RR.



The Fiberrail track cleaning tool, available in N, HO, S, and O scales, uses a microfiber cloth insert to clean grime off the rails. 30-packs of additional microfiber inserts are available. Info: [scottysmodelshop.com](http://scottysmodelshop.com)



**Tichy Train Group** has introduced an HO scale for a one-room school house. The plastic injection molded kit includes the main building an outhouse, optional doors and porch railing, and 28" of picket fence. The main building has a footprint of 2-3/4" x 4-1/2".

Info: [www.tichytraingroup.com](http://www.tichytraingroup.com)

## DISCLAIMER .....

The opinions expressed in this column are those of the writer and do not necessarily reflect the opinion of Model Railroad Hobbyist or its sponsors. Every effort is made to provide our readers with accurate and responsible news and information, however, neither Model Railroad Hobbyist or the writer of this column can be held responsible for any inaccuracies or typographical errors that may inadvertently appear in this column.



## ADVERTISEMENT

# NEW VIDEOS from the Model Railroad Hobbyist Store



**HO DCC  
Install  
examples**



**Layout  
Tours  
Volume 5**



**Signaling  
your  
layout**



**Cool Tools  
and  
tips ...**

Shop the MRH Store ▶

ADVERTISEMENT

[MRHMAG.COM](http://MRHMAG.COM)

[INDEX](#)

ADVERTISEMENT

[TABLE OF CONTENTS](#)



BRIEFLY NOTED AT PRESS TIME ...

**Moloco** has HO scale pre-painted 33" nickel-plated, insulated wheelsets in a choice of standard 0.110" or semi-scale 0.088" tread. Info: [www.molocotrains.com](http://www.molocotrains.com)

N scale passenger car specialist **RailSmith** has released Tioga Rapids, a lightweight car wearing the livery of the Texas Special as operated jointly by the Frisco and MKT railroads. RailSmith is currently taking reservations for Mount Hood, a lightweight SP&S car in the decorating scheme of the Empire Builder. Info: [www.lowellsmith.net](http://www.lowellsmith.net)

Toronto-based **Rapido Trains** is interviewing for a customer service/administrative specialist and a graphic artist. Being a lover of trains is not mandatory for either job but, by law, being a Canadian citizen is. Info: [rapidotrains.com/content/rapido-careers](http://rapidotrains.com/content/rapido-careers)

New HO models coming from **Walthers** next August include a Proto series SD45. New Mainline freight cars scheduled for release early next year include a 60' hi-cube Plate F boxcar and a 53' Railgon gondola. We'll have details next month. ■



**RATE THIS ARTICLE**

in the **NOVEMBER 2021 MRH RUNNING EXTRA!**

**Did you see this article?**



**Camas Prairie  
modular layout**

**Get this eBook now ▶**

*click here*

**MRH** **RUNNING**  
EXTRA  
Each eBook ~100 pages



**REGISTER**  
*(free)*

[INDEX](#)

[TABLE OF CONTENTS](#)

# SELECTED EVENTS



Model Railroad Hobbyist | November 2021

## NOVEMBER

***Due to COVID-19 restrictions, please check with any organization hosting an in-person event for the latest status of the event.***

### Ongoing 2021

**ONLINE, Zoom**, dates vary, see website. Operation Special Interest Group Meetups – limited attendance available.

Info: [www.opsig.org/Virtual](http://www.opsig.org/Virtual)

Archive: [www.opsig.org/Virtual/Past](http://www.opsig.org/Virtual/Past)

**ONLINE, Zoom & YouTube**, Wednesday & Saturday, see info. “New Tracks” Meetup, hosted by Jim Kellow, MMR.

Info: [newtracksmodeling.com](http://newtracksmodeling.com)

**ONLINE, Facebook & YouTube**, dates vary, see Facebook page. “NMRax” organized by Gordy Robinson, Martyn Jenkins, Gert Muller, Jordan Kramer.

Info: [www.facebook.com/groups/nmragroup](http://www.facebook.com/groups/nmragroup)

**ONLINE, YouTube**, every other Saturday. 4th Division, Pacific Northwest Region, NMRA hosts online layout tours and clinics.

Archive: [www.youtube.com/c/4DPNRMovies](http://www.youtube.com/c/4DPNRMovies)

**ONLINE, Zoom**, Second Tuesdays, 8pm EST. “Off the Beaten Track” featuring Narrow Gauge layouts, clinics and manufacturers.

Info: [groups.io/g/NNG](https://groups.io/g/NNG)



AROUND THE USA, IN-PERSON, Various dates. ScaleTrains.com  
Road Trip.

Info: [www.scaletrains.com/roadtrip](http://www.scaletrains.com/roadtrip)

## November - December 2021

**COLORADO, LONGMONT**, December 10-12, 2021, Boulder Model Railroad Club's 44th Annual Rock-n-Rails Train Show. Boulder County Fairgrounds, 9595 Nelson Road.

Info: [bouldermodelrailroadclub.org/index.php/train-expo/44th-annual-train-expo-2022](http://bouldermodelrailroadclub.org/index.php/train-expo/44th-annual-train-expo-2022)

**FLORIDA, MELBOURNE**, December 4, 2021. Original Melbourne Train and Toy Show, sponsored by Schultz Space Coast Trains, Azan Shrine Center, 1591 W Eau Gallie Blvd.

Info: [schultzspacecoasttrains.com](http://schultzspacecoasttrains.com)

**INDIANA, DANVILLE**, November 20, 2021. Danville Train Show, presented by the Central Indiana Division-NMRA. Hendricks County Fairgrounds, 1900 E. Main St.

Info: [cidnmra.org](http://cidnmra.org)

**INDIANA, FORT WAYNE**, November 20, 2021. Model Railroad Show & Swap, sponsored by Maumee Valley Railroad Club, Inc. Coliseum Bingo, 911 W. Washington Center Rd.

Info: [maumeevalleyrailroad.com](http://maumeevalleyrailroad.com)

**ILLINOIS, WHEATON**, December 12, 2021. Great Midwest Train Show, Dupage County Fairgrounds.

Info: [trainshow.com](http://trainshow.com)

**MASSACHUSETTS, MARLBOROUGH**, December 4-5, 2021. New England Model Train Expo, sponsored by the NMRA HUB Division. Best Western Royal Plaza Trade Center.

Info: [www.hubdiv.org/fallshow](http://www.hubdiv.org/fallshow)

**MASSACHUSETTS, ORLEANS**, November 27, December 4, 11, 18. Nauset Model Railroad Club Open House, Rear of Hilltop Plaza, 180 Route 6A.

Info: [www.nausetmodelrrclub.com](http://www.nausetmodelrrclub.com)



**REGISTER**  
*(free)*

[INDEX](#)

[TABLE OF CONTENTS](#)

**MICHIGAN, SALINE**, November 28, 2021. Rails on Wheels' annual Southeast Michigan Train Show. Washtenaw Farm Council Grounds, 5055 Ann Arbor Saline Road.

Info: [www.railsonwheels.com/#trainshow](http://www.railsonwheels.com/#trainshow)

**NEW YORK, HICKSVILLE**, November 26-28, December 3-5, 10-12, 2021. West Island Model Railroad Club Open House. Broadway Business Center, 485 South Broadway, Unit 22A.

Info: [www.westislandmodelrailroadclub.com/home.html](http://www.westislandmodelrailroadclub.com/home.html)

**OHIO, LIMA**, December 11, 2021, Train Town Train Show and Swap Meet, sponsored by NMRA NCR Division 3. Allen County Fairgrounds, 2750 Harding Highway. Contact Jim Marquardt, 260-437-3844 for more information.

**OREGON, PORTLAND**, November 13-14, 20-21, 27-28, December 4-5, Annual Columbia Gorge Model Railroad Club open house, 2505 N Vancouver Ave.

Info: [cgmrc.com/events](http://cgmrc.com/events)

**OREGON, RICKREAL**, December 4, 2021. Willamette Valley Model Railroad Annual Train Show and Swap Meet. Polk County Fairgrounds, 520 S. Pacific Hwy. West.

Info: [wvmrm.webs.com](http://wvmrm.webs.com)

## Future 2022-2023 by location

**NEW ZEALAND, CHRISTCHURCH**, April 15-18, 2022. Back on Track National Model Railway Convention 2022. St. Andrews College, 347 Papanui Rd.

Info: [www.modelrailcon.nz](http://www.modelrailcon.nz)

**FLORIDA, PALMETTO**, February 19-20, 2022, 43rd Annual RealRail Model Train Show, hosted by RealRail: The Railroad Education and Learning Center of Florida. Bradenton Area Convention Center, 1 Hazen Blvd.

Info: [realrail.org/upcoming-events/rail-pass](http://realrail.org/upcoming-events/rail-pass)

**MASSACHUSETTS, WEST SPRINGFIELD**, January 29-30, 2022. Railroad Hobby Show sponsored by the Amherst Railway Society. Eastern States Exposition Fairgrounds, 1305 Memorial Avenue.

Info: [www.railroadhobbyshow.com](http://www.railroadhobbyshow.com)

**MISSOURI, St. LOUIS**, August 7-14, 2022, NMRA National Convention and National Train Show. St. Louis Marriott Grand Hotel, 800 Washington Avenue.

Info: [gateway2022.org](http://gateway2022.org)

**OREGON, EUGENE**, May 10-14, 2022. PNR 2022 Regional Convention, Valley River Inn.

Info: [pnr.nmra.org/1div/Eugene2020/home.htm](http://pnr.nmra.org/1div/Eugene2020/home.htm)

**PENNSYLVANIA, MALVERN**, March 24-27, 2022, Valley Forge Railroad Prototype Modelers 2022. Desmond Malvern Conference Center.

Info: [www.rpmvalleyforge.com](http://www.rpmvalleyforge.com)

**TEXAS, GRAPEVINE (Dallas Area)**, Summer 2023, NMRA National Convention, Gaylord Texan Resort & Convention Center, 1501 Gaylord Trail.

Info: [www.2023texasexpress.com](http://www.2023texasexpress.com)

**TEXAS, PASADENA (Houston Area)**, February 12, 2022, The Greater Houston Train Show, presented by the San Jacinto Model Railroad Club. Pasadena Convention Center, 7902 Fairmount Parkway.

Info: [sanjacmodeltrains.org](http://sanjacmodeltrains.org) ■



**RATE THIS ARTICLE**

in the **NOVEMBER 2021 MRH RUNNING EXTRA!**

**Did you see this article?**



**In praise of dabbling**

**Get this eBook now ▶**

*click here*



**RUNNING**  
EXTRA  
Each eBook ~100 pages



**REGISTER**  
(free)

[INDEX](#)

[TABLE OF CONTENTS](#)



It's all about trains



All things train related,  
whenever, wherever.



[WWW.24TRAINS.TV](http://WWW.24TRAINS.TV)

**On 24TRAINS.TV you can find:**

videos | travel reports | magazines | vlogs

model railways | workshops | documentaires | holidays



# REEFER MADNESS



# CLICK HERE!



[REGISTER](#)  
*(free)*

[INDEX](#)

[TABLE OF CONTENTS](#)

# CLICKABLE ADVERTISER INDEX

[Accu-Lites](#)  
[Amherst Railroad Hobby Show](#)  
[Archer Fine Transfers](#)  
[Atlas Model Railroad Co.](#)  
[Bachmann](#)  
[Berrett Hill Trains](#)  
[Black Cat Publishing](#)  
[Blair Line](#)  
[Canyon Creek Scenics](#)  
[Coffman Graphics](#)  
[Conowingo Models](#)  
[Crew Call with Mike Rose](#)  
[Digitrax \(2 page spread\)](#)  
[East Coast Circuits](#)  
[ESU LokSound](#)  
[Fast Tracks](#)  
[GHB International](#)  
[Great Decals](#)  
[Humancity Junction](#)  
[Inter-Action Hobbies](#)  
[Iowa Scaled Engineering](#)  
[ITLA Scale Models](#)  
[KR Models](#)  
[Litchfield Station](#)  
[Logic Rail Technologies](#)  
[Maple Leaf](#)  
[Micro-Trains Line](#)  
[miniprints](#)  
[Model Railroad Control Systems](#)  
[Model Rectifier Corp](#)  
[Model Tree Store](#)  
[Monashee Laser Engineering](#)  
[Monroe Models](#)  
[Mountain Pacific Scenics](#)  
[Mountain Subdivision Hobbies](#)  
[MRH Store \(1\)](#)  
[MRH Store \(2\)](#)  
[MRH Store \(3\)](#)  
[MRH Store \(4\)](#)

[Mt. Albert Scale Lumber](#)  
[Murder to Scale](#)  
[NCE \(2 page spread\)](#)  
[New Creations](#)  
[North American Railcars \(PWRS\)](#)  
[Pre-Size Model Specialities](#)  
[Precision Design Co.](#)  
[Rapido \(1\)](#)  
[Rapido \(2\)](#)  
[Ring Engineering \(1\)](#)  
[Ring Engineering \(2\)](#)  
[Roomettes](#)  
[Scale Trains](#)  
[Sceniking.com](#)  
[Soundtraxx](#)  
[Southern Digital](#)  
[Southwestern Rail Systems](#)  
[Squeaky's Trains](#)  
[Streamlined Backshop \(1\)](#)  
[TAM Valley Depot](#)  
[The Trainmaster Inc](#)  
[TrainMasters TV](#)  
[24 Trains.tv](#)  
[Walthers](#)  
[Westerfield Models](#)



In the **NOVEMBER 2021 MRH RUNNING EXTRA!**  
Did you see this article?  
**Better detail painting brushes**  
Get this eBook now! <- click here  
Each eBook ~100 pages  
**MRH RUNNING EXTRA**

[Clickable "other" index](#)  
[Other – Contents](#)  
[Other – Cover](#)  
[Other – MRH Marketplace](#)  
[Other – MRH Sponsors](#)

# Coming next month in MRH ...

Bob Rivard upgrades an Athearn covered hopper ...

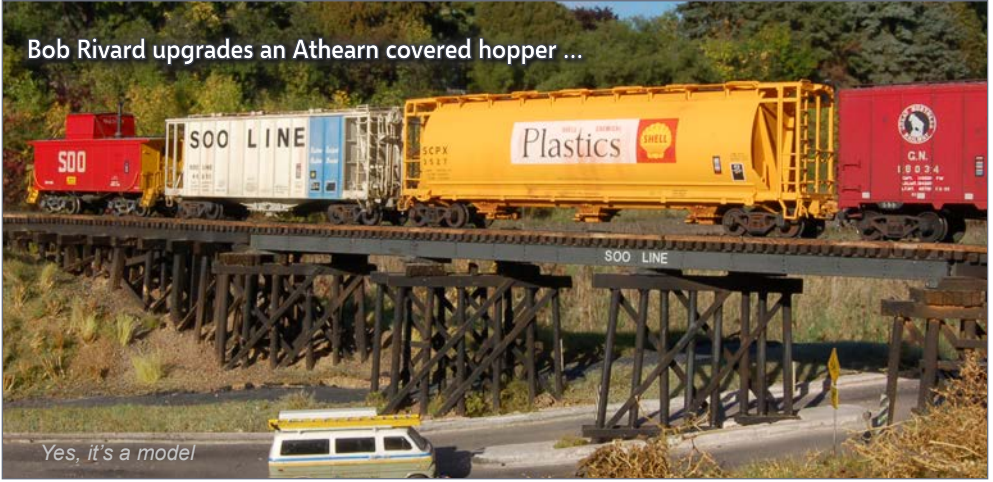

*Yes, it's a model*

Henry van Wyk builds suction-operated semaphores ...



Add a "live" horn to your layout ...

... coming December 15<sup>th</sup> in the  
December MRH



**REGISTER**  
*(free)*

[INDEX](#)

[TABLE OF CONTENTS](#)



# Coming next month in Running Extra ...

## ... all the MRH articles and ads, PLUS:

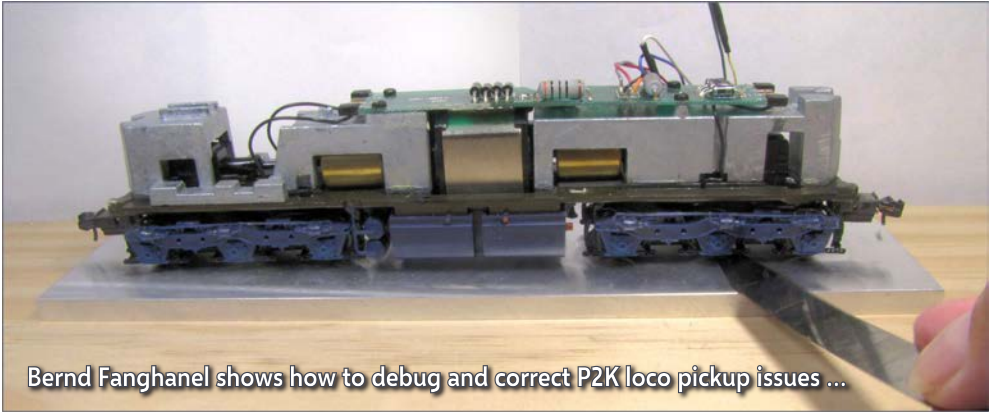

Bernd Fanghanel shows how to debug and correct P2K loco pickup issues ...



Do historically accurate models matter?

December 2021 - \$2.99

**MRH** **RUNNING**  
##### **EXTRA**  
Apprentice with savvy modelers

**Bernd Fanghanel shows how to ...**  
**Debug P2K loco pickup issues**  
▶ **READ NOW**



**Also these articles:**

- Lorem ipsum dolor sit amet
- Consectetur adipiscing elit morbi
- Vestibulum tempus vehicula
- Mauris tempor libero ipsum pellentesque
- Nullam porta ut arcu at lobortis
- ... and much more!



Modeling a railroad tie maintenance scene ...

## ... all this and much more!

**SUBSCRIBE AND SAVE UP TO 75%**