

Model Railroad Hobbyist magazine™

January 2013

Price: *Forever Free*

New "Yes, it's a model"
photo feature!

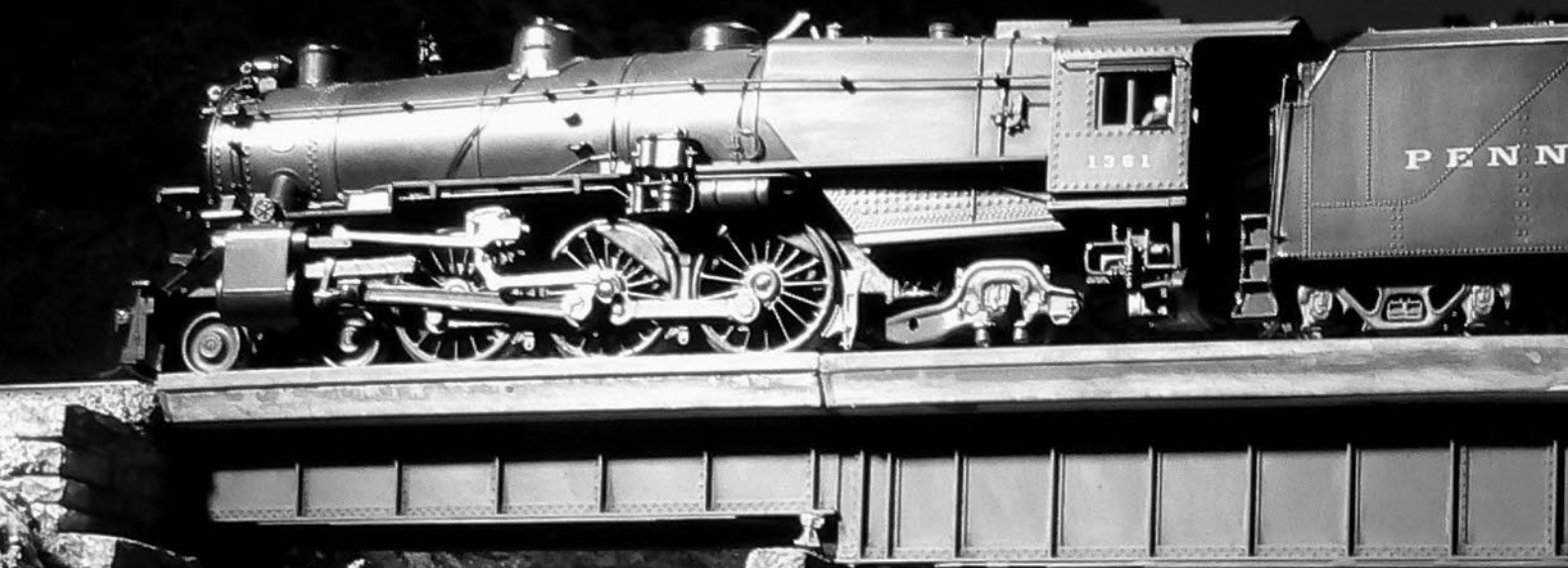

- Fort Wayne Union Railway
MRH Starter contest winner
- Sound decoder install how-to
- Roadbed, backdrop, lighting tips



Looking for the
landscape version?
Then click here.

HAVING FUN WITH TRAINS



Embedded edition - portrait



download



contents



index

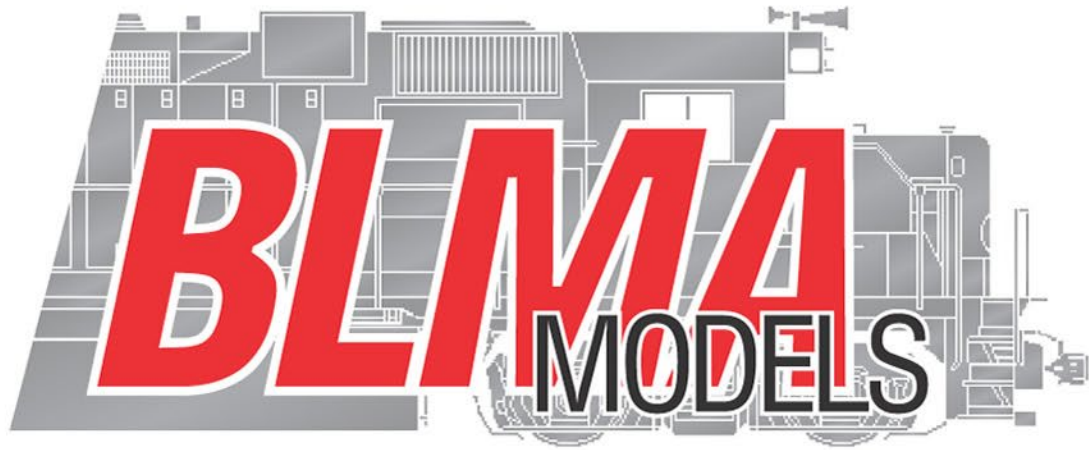

THEY'RE COMING

HO & N

Photo by Joe Shaw

AND NOW WITH SMOOTH TUBS!

CLICK HERE TO SEE MORE



Email



Phone



contents



index

Model Railroad Hobbyist magazine™

Front Cover: No, it's not a newly discovered O. Winston Link photo – it's modeler Jay Herr's photo of his HO layout. In this first of our new Gen2 magazines, we're introducing a new monthly photo feature we're calling "Yes, it's a model".

ISSN 2152-7423

Editorial Staff

Joe D. Fugate, Publisher and Editor

Production

Patty Fugate, pasteup and layout

Joe Brugger, copy editing

Mike Dodd, copy editing

Technical Assistants

Jeff Shultz

Jimmy Simmons

Advertising

Les Halmos, Account Manager

Daniel Nava, Advertising Assistant

Published for the glory of God. [What's this?](#)



Columnists

Richard Bale, News and events

Jeff Shultz, News and events

John Drye, N scale

Les Halmos, Modular railroading

Ken Patterson, Reporter at large

Bruce Petrarca, DCC

Special Correspondents

Joe Brugger, Questions & answers

Charlie Comstock, Contributing editor

Cover and MRH masthead



contents



index



click to learn more about this sponsor



NEW SPONSOR!



click to learn more about this sponsor



click to learn more about this sponsor



click to learn more about this sponsor



click to learn more about this sponsor



click to learn more about this sponsor



NEW SPONSOR!



click to learn more about this sponsor



click to learn more about this sponsor



click to learn more about this sponsor



click to learn more about this sponsor



click to learn more about this sponsor



click to learn more about this sponsor



NEW SPONSOR!



click to learn more about this sponsor



click to learn more about this sponsor



click to learn more about this sponsor



click to learn more about this sponsor



click to learn more about this sponsor



click to learn more about this sponsor



NEW SPONSOR!



NEW SPONSOR!



click to learn more about this sponsor



click to learn more about this sponsor



click to learn more about this sponsor



NEW SPONSOR!



NEW SPONSOR!



NEW SPONSOR!



click to learn more about this sponsor



click to learn more about this sponsor



click to learn more about this sponsor



NEW SPONSOR!



click to learn more about this sponsor



click to learn more about this sponsor



click to learn more about this sponsor





click to learn more about this sponsor



click to learn more about this sponsor



click to learn more about this sponsor



click to learn more about this sponsor



click to learn more about this sponsor



click to learn more about this sponsor



click to learn more about this sponsor

Want your logo on this page? Click to find out how....

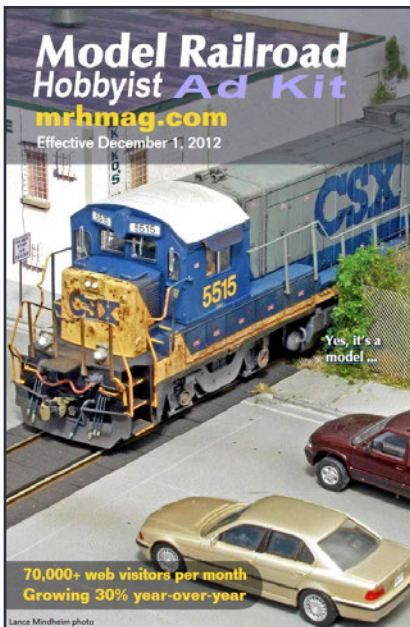

72,000+ audience as of December 2012.

[Tell me more](#)



Looking for something? Check our Hobby Marketplace!

[Take me there](#)





EXACTRAIL[®]

The Next Generation of Model Railroading



[LEARN MORE](#) 

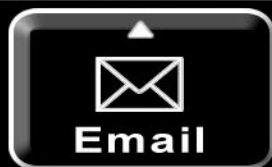

Email



Phone



contents



index

Table of Contents - 1

Main Features

*Click title
to view*

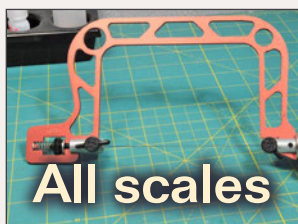

Tool Shed: A better jeweler's saw

Get an improved version of this useful tool

by Jack Burgess

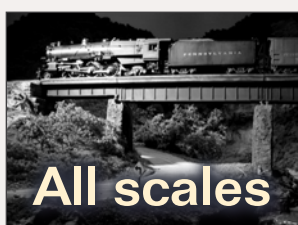

Yes, it's a model

MRH's new monthly photo feature

Compiled by the MRH staff



Optimum layout size for Ops?

Determine how much layout you can operate

by Lance Mindheim

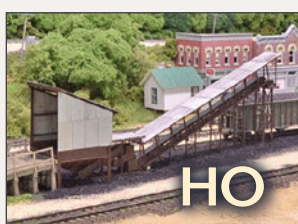

Building a coal loader, part 2

A backwoods industry for your layout

by Tom Patterson

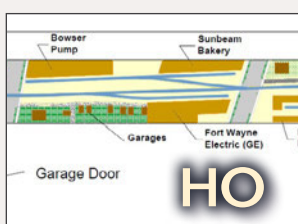

Fort Wayne Union Railway

\$500 contest layout grand prize winner

by Don Hanley



MRH Product Showcase

North American Railcar grain & potash hoppers

by the MRH staff



January Model Railroading News

MRH news and events

by Richard Bale and Jeff Shultz

Table of Contents - 2

Other Features

*Click title
to view*

- [Adapting model RR publishing](#) **Publisher's musings**
by Joe Fugate
- [MRH Staff Notes](#) **Making the most of Gen2 ...**
by the MRH staff
- [MRH Q - A - T](#) **Questions, Answers, and Tips**
compiled by Joe Brugger
- [Hobby Marketplace](#) **Vendor ads**
- [Derailments](#) **Humor?**

Columns

- [NW2 sound installation](#) **DCC Impulses**
by Bruce Petrarca
- [Roadbed, backdrop, lighting](#) **Getting Real**
by Nick Muff
- [Jeff Meyer's freight cars](#) **What's neat this week**
by Ken Patterson
- [Newbies: Start with the train](#) **Reverse Running**
by Ken Sipel

Subscriber-only extras (*subscribers click here to access*)



*Two B or Not Two B...
That is the Model.*



*Clickest here for
more information*



Email



Phone



contents



index



Adapting model railroad publishing to the times

The next generation of MRH



Publisher's Musings editorial
by Joe Fugate



Marketing 101 says you sell more wares by making yourself more easily found by those who need what you offer. In the 21st Century, the way people look for what they need is changing, so publishers need to adapt if they expect to reach and grow their audience.

Model Railroad Hobbyist launched in 2009 as a new media digital publication for model trains. We adopted the Google model of free content funded by advertising, and we've grown steadily at 30% plus per year to reach an estimated audience of over 70,000 per month. In the last 12 months, our largest growth has come from readers with mobile devices.

However, we designed MRH in 2008 when there were no tablets and the first smartphone, the iPhone, was barely a year old. Things have changed dramatically in 4 short years, and it's time for MRH to adapt. Enter MRH Gen2.

With Gen2 we've given MRH a major facelift so it's far more easily consumed on mobile devices like smartphones and mini-tablets. Let us know what you think of the new MRH format!



We hope you find our new mobile-friendly version to be a great way to catch up on your MRH reading while on the go.

As we continue to evolve MRH, we're not just thinking about techno-geek stuff. We're also masterminding better ways to bring you superior content with the most effective solutions to your model challenges that we can present.

One example of this is our new *Yes, it's a model* monthly photo feature. We're seeing a lot of inspiring modeling posts on the MRH website these days, so we're using this new monthly feature to give you a heads up from the best modeling posts on our site.

We also expect to start publishing ad-free eBooks this year. Some of the eBooks will be republished MRH content organized by topic. Other eBooks will be all-new material we've never published

**OUR MY RAILROAD
APPS + TOOLS
ARE THE SAME PRICE
AS THIS MAGAZINE.**

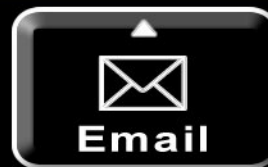

**When talking
to hobby
vendors,
please
remember
to mention
MRH.**



before. Because these eBooks don't have ads, they will have a cover price – but rest assured, we embrace the micro-pricing of eBooks, so we'll price them to be much more affordable than paper books, and they will be available for instant download!

We're planning to give our website a major upgrade as well this year, with more features and capabilities added than ever.

Yes, we see 2013 shaping up to be a good year for MRH and the hobby. Please use the comment thread button here to let us know your thoughts on the new Gen2 format!

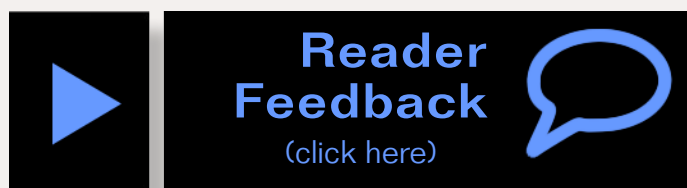
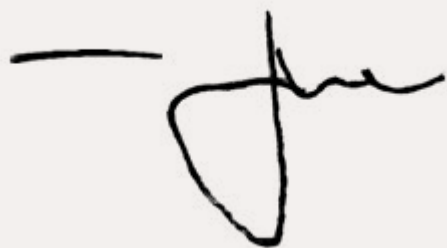

Advertisement

An all Basswood Kit!, No Plaster or Resin!

STARTER STRUCTURES

The Kit You Custom Fit

WHAT DOES YOUR LAYOUT NEED?

Many Custom Options Available!



Your Choice of Cornice

-Flat or Round

You Determine the Inscription

-Dates, Names, Towns, Etc...

MONSTER
model & laser works

CUSTOMIZE YOUR KIT TODAY!

www.monstermodelworks.com



HO SCALE
&
N SCALE



Litchfield



S T A T I O N

Ring in the New Year with DCC!
Featuring **39** Major Suppliers, Including:

Blackstone  Models™



Tsunami®

The **Best** in
Digital Sound -
only from
SoundTraxx!

www.Mr-DCC.com

623-298-7355

1-(888)-395-3976



Notes from the MRH STAFF

All about Gen2, MRH Contest winners...



All about MRH Gen2

We've been talking a lot about our new MRH Generation 2 format, and now you're looking at it! The changes we've made make the magazine easier than ever to read on mobile devices like smartphones and 7" tablets. Along the way, it sets the stage for our eventual move away from the PDF format completely and to the more device-independent and more feature-rich HTML5 format.

The HTML5 move has yet to happen because it's still slightly too bleeding edge for us to make the plunge just yet. However, with our move from our previous format (we're calling it Gen1) now to Gen2, we have also introduced a more mobile-friendly online provider: Flippingbook rather than ISSUU.

As you can see, we've split the page down the middle and we've increased our body font size by 20%. We've also streamlined our page formatting to make it less busy and have a bit more "white space" around things. This all should make MRH easier to read on smaller mobile device screens.



December 2012 MRH Ratings

The five top-rated articles in the [December 2012](#) issue of MRH are:

- 4.5 Slow orders - dangerous track ahead!
 - 4.5 DCC Impulses - Basic electronics for DCC
 - 4.5 Modeling a coal loader, part 1
 - 4.4 What's neat - Model railroad artist Mike Budde
 - 4.1 Car Shop - Classic track-cleaner
- Issue overall: 4.6

Please rate the articles!

Click the reader feedback button on each article and select the star rating you think each article deserves. ***Thank you!***

Advertisement

Railroad Explorer Magazine

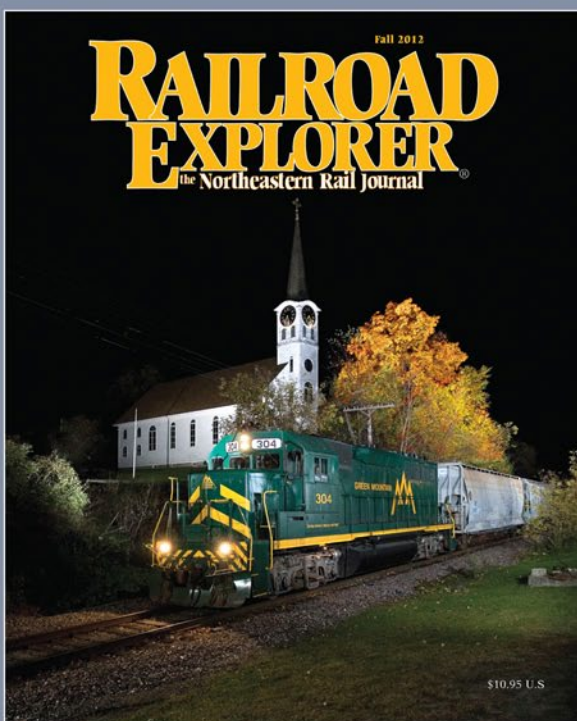

- Three, all-color issues per year.
- Exciting feature stories, spectacular photos.
- Best-in-class photo reproduction.
- Printed on heavy, glossy paper.
- Zero advertising. All content.
- Winter, Spring/Summer and Fall editions.

Issue 36 - Fall 2012

On sale now

Subscribe Today!

www.railroadexplorer.com



Email



Phone



contents



index

Along with the Gen2 page formatting changes, we've also altered how ads work by adjusting them to fit our new portrait page orientation. In addition, on our sponsoring advertiser ads, we now include an email and phone button to make it one-click easy (or should we say *one-tap easy*) for you to directly contact an advertiser (1).

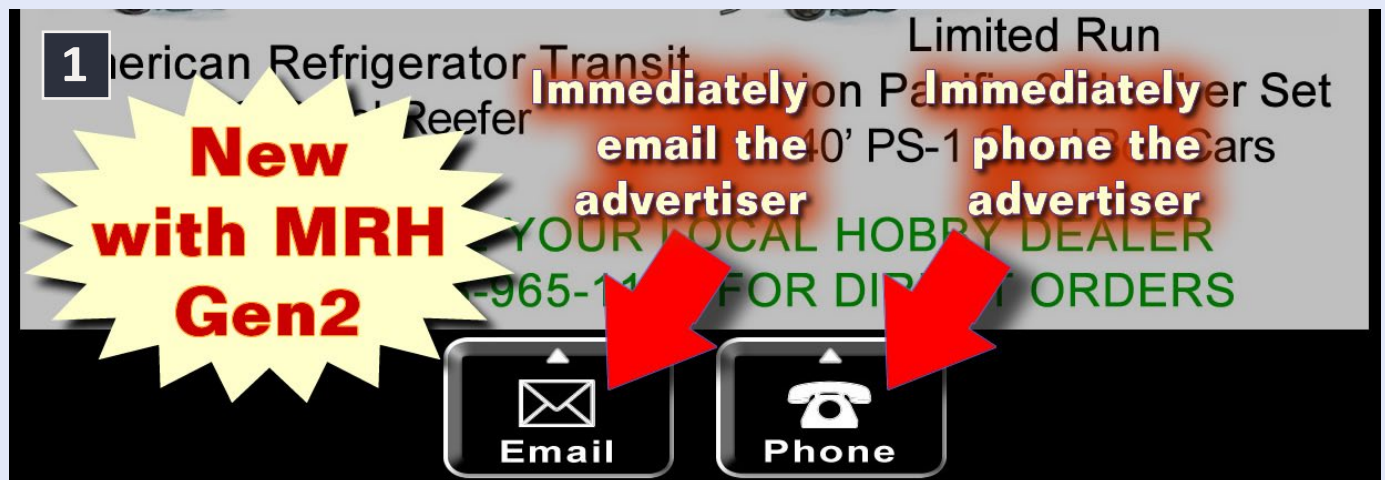

1: Our sponsoring advertiser ads now include buttons for directly emailing or phoning the advertiser. We hope more than a few of you will at least try this new feature by emailing your favorite advertisers and thanking them for being an MRH sponsor!

Advertisers often keep spending ad dollars based on clues from readers that their ads are getting noticed. If we make it one-click easy for you to send a quick email off to an advertiser or to call them with a question - or better yet to place an order - then they will immediately see the benefit of advertising with MRH over the paper magazines.

And on a smartphone, you can literally tap the phone button on the ad and immediately be ringing the advertiser! How cool is that?

But it all depends on you actually clicking or tapping on those buttons to let them know you're seeing their ads!

Depending on what device (and orientation) you're using to read the new Gen2 format, we have some recommendations for the best reading experience.

On iPads and iPhones

For iPads and iPhones, we recommend the GoodReader app (\$5). For iPads in landscape orientation, we find facing pages to give the best reading experience. Use the Pages Layout setting Double Pages with Front Cover (2). For iPhones, using

2: For GoodReader on an iPad in landscape orientation, set the Pages Layout to Double Pages with Front Cover to get a screen-filling facing pages view similar to Gen1.

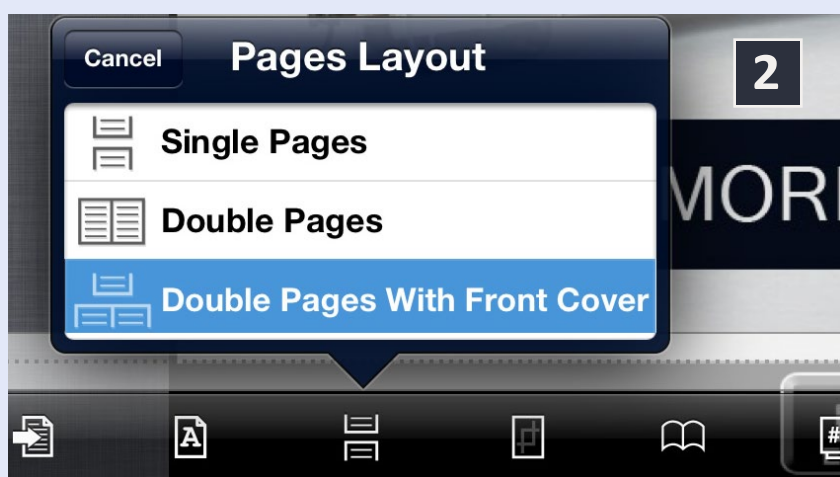

Advertisement



Rusty Stumps

Scale Models

WE ONLY SELL WHAT WE MANUFACTURE

DETAILS IN HO, O, S & N SCALES
LASER CUT SHINGLES, DOORS & WINDOWS,
FENCES, SIDING, CRATES. Also RESIN and
WHITE METAL DETAILING CASTINGS.

CRAFTSMAN KITS
IN HO, O & S SCALES

CHECK IT ALL OUT AT
WWW.RUSTYSTUMPS.COM

Send \$3.50 for Catalog - Specify Scale

RUSTY STUMPS SCALE MODELS

6785 Cherry Blossom W. Dr., Fishers IN 46038

Phone (317) 595-9489



Single Pages in Portrait works best. A single portrait page will fill the screen and if you have normal 20-20 vision (or equivalent with corrective lenses) then you will be able to read the text.

On Android tablets and smartphones

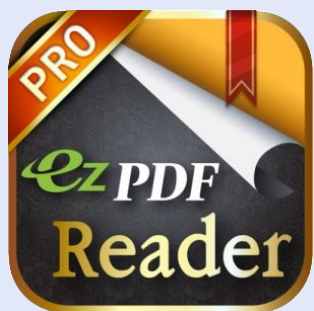

For Android tablets and smartphones, we recommend the ezPDF Reader PRO app (\$2). For 7" tablets and phones, a portrait orientation with the Single Page setting is the most readable. For larger 10" tablets, you can use Double Pages in the ezPDF Reader settings to get a facing page spread. With our larger Gen2 fonts, the two-page spread view is quite readable on larger Android tablets.

Improved Online edition

With the release of Gen2, we've also moved to an improved Online edition that



Smartphones



Mini-tablets



10" tablets and Computer screens
(facing page spread)

Our new format that's great on mobile screens
(yet still looks good on larger screens as a facing page spread)

3: With MRH Gen2, MRH can look good on more devices than ever. Facing pages on larger screens gives a Gen1-like view.



looks good on mobile devices as well as on computer screens. For the smallest mobile device screens, we still recommend downloading the PDF and reading it using GoodReader (iOS) or ezPDF Reader (Android).

The PDF version fills the screen better, not to mention having a local copy of MRH on the device gets past any web slowness you might encounter. The bottom of the front cover has a download button on it to make downloading a local copy of MRH easier than ever.

Look Ma, no page numbers!

With Gen2, we've also stopped using page number references in the text. You now click on any content references to go to a "page". This makes it easier for us to eventually produce versions of MRH for the Apple iBooks and Amazon Kindle bookstores (coming later in 2013).

January 2013

Bonus Extras!

Available to subscribers!

DVD and HD quality versions of the videos in this issue, plus:

- **Scalable PDF versions of the Fort Wayne Union Railway drawings**

[Click here to access](#)



contents



index

Just remember everything is clickable, so click away! The cover teasers, the table of contents, the index, and even page references in the text are all clickable. You don't really need page numbers any longer with a digital publication because it's easy to get anywhere you need to go just by clicking.

The one thing that's always true with change is that it can be disorienting at first. We're expecting to get more questions and some grumbling asking why we couldn't just leave well enough alone? Please give it a few issues for you to get used to things.

From the issue assembly side, we're getting used to the changes (since we're a few months into them already with all the issue planning and article pasteup we've been doing) and we're starting to really like the new cleaner, spacier look.

Make sure you click on the comments button and let us know what you think.

MRH \$500 Starter Layout Contest



The MRH \$500 Starter Layout Contest concluded at the end of November, and we've judged the entries. The idea with this contest, of course, was to see how clever modelers could be with starter layout ideas. And as a side benefit, the contest gives us many small layout articles in our article backlog for future issues!

Judging criteria included how easy the layout is to build, how well the design works as a base to build on for the future, how interesting the layout is (and would it maintain a newbie's interest), how much outside-the-box thinking the approach entails, and how well-prepared as an article is the submission?

After a lot of debate and discussion, along with considerable thought as to scoring the submissions, we have our winners:

- **Grand Prize:** Don Hanley - Fort Wayne Union Railway layout.
- **First Place:** Douglas Forbes - Western Expansion layout.
- **Second Place:** Michael Brown - N-scale 2x4' layout.
- **Third Place:** Ben Kaur - Xtrack CAD layout.

Honorable mentions ...

- **Chris DiPaolo - Urban action:** Clever use of space, but traction layout is of limited interest.
- **John Dimitrievich - Chicago Fork:** Out-of-the-box benchwork methods, provides a lot of layout for its micro space.

In this issue, we publish the Grand Prize winner's entry. In



2013

YD
Yankee Dabbler.Com

Click to see our ...

January Specials
(while supplies last)

Click to see specials in these categories

- HO
- DCC
- All Scales

- **Digitrax**
- **SoundTraxx**
- **Kadee**
- **NCE**
- **And more!**

HOT!



Click here for more info ...

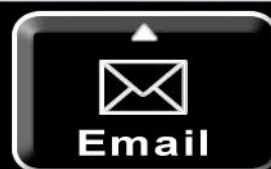

future issues, we will be publishing the other winning entries, so watch for them!

We get emails from readers asking for more small layout designs, so here you go. We have a good half-dozen such designs we will be publishing this year, all aimed at getting you going for \$500.

Who's reading MRH?

2013 Reader Survey

[Take survey now](#)

click here

**Survey should
take about 10
minutes ...**



MRH 2013 Reader Survey

Our last full reader survey was in 2011, so it's time for another. We had only about 40,000 monthly visitors in 2011, and we're expecting to break 80,000 visitors by the end of January (we're already at almost 75,000 in December), so there's a lot of new blood in our visitor ranks that we'd like to hear from.

Take our survey and let us know who you are and what you'd like to see more of in MRH. We'd also like to know how you're reading MRH these days, given the new mobile device trends.

[... On to next page of text →](#)



SO REAL...You'll Think You're There!

LokSound Select · 3 SIZES, ENDLESS POSSIBILITIES!

**INDUSTRY LEADING
MOTOR CONTROL**

- Multiple Bell types
- Multiple Brake squeals

**4 OR 8 Ohm
SPEAKERS!**

- 4 or 6 Output functions depending on the style
- Up to 4 Prime Movers or Steam Sounds on EACH decoder
- 16 Very Playable, LOUD Horns or Whistles depending on Profile
- All Changeable by using ONE CV! No Programmers or Boosters needed!*

**Small Size
BIG POWER! 1.1Amp!
LokSound Select
"4 AUX"**



\$99.99

NEW 2011

LOK SOUND SELECT

Only Available From ESU LLC (USA) 

- Great NEW Size 1.18" x 0.61"
- Versatile DCC & DC "Dual Mode" decoder!
- 8 channel sound system!
- FOUR lighting outputs and a 1.1A motor controller
- Available with ALL Current LokSound Select Sound Profiles
- Use 4, 8, or 16 Ohm Speakers

**ONE SIZE FITS ALL!
LokSound Select "DIRECT"**



\$109.99

**6 Outputs!
LED Resistance
Built In!**

NEW 2011

LOK SOUND SELECT

Only Available From ESU LLC (USA) 

- Easy Drop in Design
- Versatile DCC & DC "Dual Mode" decoder!
- 8 channel sound system!
- SIX lighting outputs ALL with built in resistors for LEDs
- Available with ALL Current Diesel Sound Profiles
- Use 4, 8, or 16 Ohm Speakers

**Tiny Size,
HUGE Versatility!
LokSound Select
"MICRO"**



\$99.99

NEW 2011

LOK SOUND SELECT

Only Available From ESU LLC (USA) 

- Great NEW size ONLY 0.98" x .417"
- Versatile DCC & DC "Dual Mode" decoder!
- 8 channel sound system!
- FOUR lighting outputs and a .75A motor controller!
- Standard 8-pin NEM 652 plug included
- Available with ALL Current LokSound Select Sound Profiles
- Use 4, 8, or 16 Ohm Speakers!

* ESU LokProgrammer needed to "Replace" Sound and for Firmware updates, not for normal editing

www.LokSound.com • 477 Knopp Drive Muncy, PA • 570-649-5048

Now on facebook!



[← back to previous page of text ...](#)

What's in this issue ...

Besides our new monthly photo feature this issue, we have ...

A better jeweler's saw: Jack Burgess shows us how to get an improved version of this useful tool, with blades that last!

Optimum layout size for ops: Lance Mindheim demonstrates using operation to determine how much layout you truly need.

Building a coal loader, part 2: Tom Patterson finishes off the backwoods coal loader he started last month.

Fort Wayne Union Railway: Our grand prize starter layout contest winner, Don Hanley, presents his winning \$500 layout design.

MRH Product Showcase: We treat you to a special product showcase of ten North American Railcar grain and potash cylindrical hoppers, all as 3D click-n-spins!

NW2 sound installation: MRH DCC columnist Bruce Petrarca shows in detail how to install sound into a Kato NW2.

Roadbed, backdrop, and lighting: *Getting Real* guest columnist Nick Muff goes beyond pure prototype modeling this time to discuss his roadbed, backdrop, and lighting methods. Not exactly prototype modeling, true, but we requested Nick write this up for us, so allow us this indulgence. You won't be disappointed!

Jeff Meyer's freight cars: Ken Patterson turns his camera toward some awesome HO model freight cars by Jeff Meyer.

All this, plus our usual editorials and January news / events all await you in the January MRH! ■

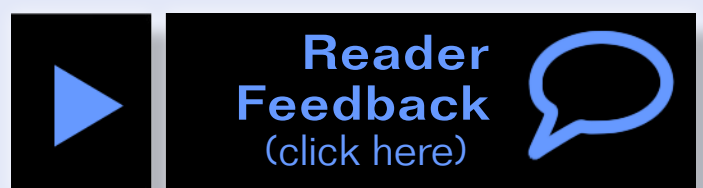

NEW for JANUARY!

HQ & N Scale

87-1395, 60-1395
Ontario Northland (ONT)
New Image Diesel
Hood Units
Including SD75i



87-1396 & 60-1396
HERZOG and RailGon
Assorted Gondolas
Ortner, Trinity, NSC, etc
Includes 80's era:
Greenville/Thrall 2494



87-1397 & 60-1397
Union Pacific (UP)
Yellow Sans-Serif
Lettering
Heavyweight
Dark Olive
Passenger Cars

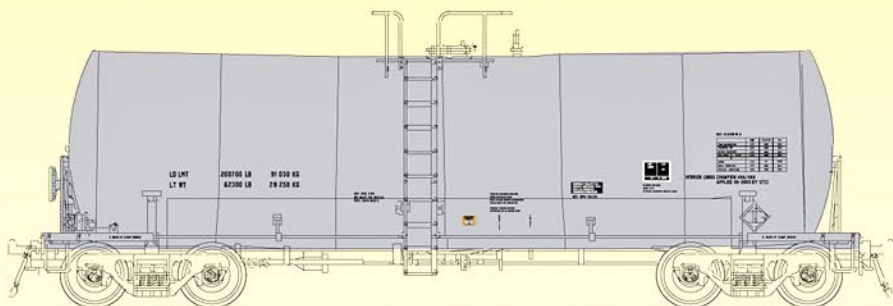

MC-5019, 60-5019 (BLACK)
MC-6020, 60-5020 (WHITE)
Misc. Tank Car Data
Trinity 17,600 gal, ACF 17,360 gal,
ACF 13,00 gal ACID, and
LPG Tank Cars

DECEMBER NEW RELEASES

[click here](#)

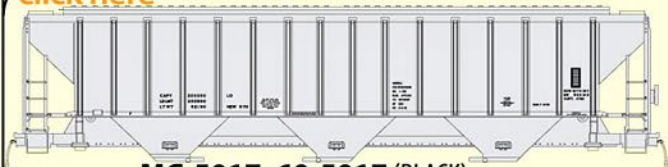

MC-5017, 60-5017 (BLACK)
MC-6018, 60-5018 (WHITE)
P.S. Covered Hopper Data 4000-4750cuft

[click here](#)



87-251 & 60-251
Burlington Northern Common Standard
Heralds and Lettering for 40' and 50'
Post-BN Merger Boxcars

[click here](#)

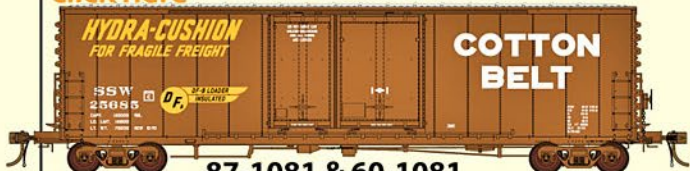

87-1081 & 60-1081
Cotton Belt Common Standard Heralds and
Lettering 40' and 50' Boxcars

[click here](#)



87-272 & 60-272
Western Pacific Modernized Feather
Herald for PC&F and FMC double door boxcars



microscale.com

MADE IN THE USA



Enjoy Great Operation ...



\$455.00 MSRP

Super Chief Xtra



**LocoNet
Is The Digitrax Difference**

- Run Trains
- Sound
- Feedback
- DC Control
- Computer Control
- Lighting
- Turnouts
- Signaling
- Transponding
- Block Detection



...With **Digitrax**



\$225.00 MSRP
Zephyr Xtra

Free Digitrax Toolbox App!
*Easy to use tools to enhance your
Digitrax experience!*

For iPhone/iPad and Android

**Download now @
www.digitrax.com!**



MRRH

Questions, Answers and Tips

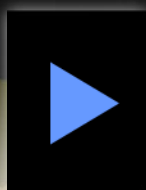

Reader
Feedback
(click here)



QUESTIONS AND ANSWERS

Q. When I was a member of the Abington Lines Model Railroad Club a LONG time ago, the member who was in charge of the wiring was an electrical engineer. As such we had very good documentation of where each and every wire went and what it did. He did this with a combination of a spreadsheet and software that produced a wiring schematic. I was wondering if anybody does this and what software they use?

A. Alan (LKandO) used Adobe Illustrator to make his relay panel schematic without a specific schematic plug-in. The design (illustration at: mrhmag.com/node/8976) is made from ordinary lines, circles, and arrows and prints beautifully. He plans to do the same for the rest of his railroad as it progresses.

Ken (Logger01) adds, “as an EE I have probably used every professional electrical design capture and automation software application available, however, these large systems are overkill



for what is needed to document most model railroad layout schematics. For most hobby applications we only need to capture the layout schematic(s), produce a net (interconnection) list, produce a list of components, and be able to share these with other interested parties.

“There are several free applications which meet these needs and more. At the moment I feel that the most capable is the EAGLE (Easily Applicable Graphical Layout Editor) available from CadSoft (cadsoftusa.com/?language=en). EAGLE is well supported, and has a good basic component library with more components available through a large user community. Users can also create their own application specific component (i.e., command stations, boosters, decoders, signals, switch panels, occupancy detectors, turnout motors). EAGLE also supports multi-page designs, and for the truly serious designer printed circuit board design and development.

“As with all design tools there is a bit of a learning curve, but I feel that the results can be well worth the effort.”

In addition to paper documentation, it is also very useful to identify the physical installation under the layout. Office supply and many big box stores sell inexpensive labeling machines that can be used to label connection points and identify wire runs. Here is a sampling available from Staples: www.staples.com/Label-Printers/cat_CL140802.

– Alan, Ken, MRH

Q. Ballasting trackwork is an area of weakness for me. The track on my HO layout is on Masonite splines with Styrofoam terrain covered with plaster cloth and Joe Fugate’s plaster vermiculite mix. I’m using Woodland Scenics medium ballast, wetting it with 70% isopropyl alcohol, and gluing it down with a 3/1 glue/water mix with a trace of dish detergent. Here are the problems I’m having: The plaster cloth detaches and curls



contents



index

up; the ballast sort of “puffs up” as it dries and looks generally lumpy, and the ballast separates from the edge of the ties by about 1/16 inch in places. I’m contemplating switching to water/dish soap as the wetting agent. Does anyone have some suggestions?

– Mike Lozensky

A. Ballasting is one of those model railroading basics that sounds simple but can be very difficult and frustrating to get right. The issue comes up frequently on the MRH Forum.

Let’s approach the issues one by one.

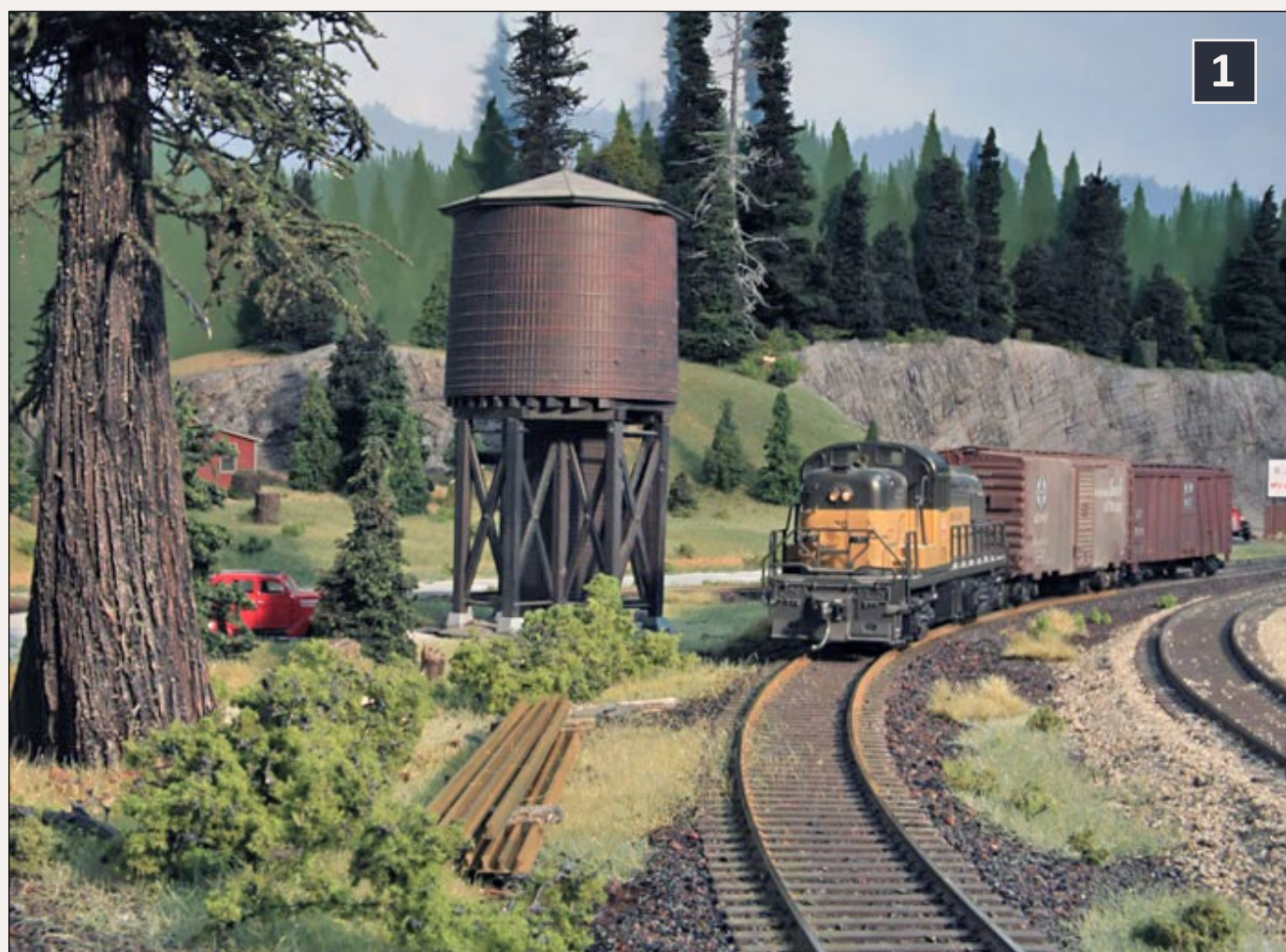

1: Charlie Comstock selected different colors and sizes of ballast at Sheffield Creek at Oakhill on the Bear Creek & South Jackson, with a tall, orderly profile on the mainline at right, and older ballast on the siding. Grass and weeds are creeping into the siding. Charlie Comstock photo.

Curling plaster cloth: Joe F. prefers masking tape as a base scenery form instead of plaster cloth. Rio Grande Dan advises using a water-resistant exterior glue, like Titebond II Premium Wood Glue to hold down the plaster cloth. Paint down a generous 3-inch wide layer, then press the plaster cloth into the glue and let it harden. Plaster cloth must be applied drippy-wet to get a lasting bond. Water-based ballast glues shouldn't ruin plaster cloth scenery once it has dried. A second layer of plaster cloth may be needed to get a rigid, nonporous structure.

Glue: In his question, Mike mentions a 3:1 glue to water ratio but several commenters said this is backwards. Elmer's Glue dries clear and a little flexible. It works well in ratios from four to two parts water to one part glue. Experiment on a test patch. Too much glue and the adhesive doesn't flow into the cracks and crevices in the ballast. Too much water and you have to deal with loose grains of ballast. If your glue beads up, the ballast hasn't been dampened thoroughly.

Wetting agents: Dishwashing liquid, alcohol and Rain-X were all mentioned. Just a tiny amount is needed to make the glue mixture flow into the applied ballast. Too thick of a glue mixture can make ballast clump and ball up.

Ballast materials: For years, wood products like bits of cork and crushed walnut and pecan shells were about all that was available, though you can go back into the 1950s and find reference to roofing granules. In the past couple of decades, modelers have adopted commercial crushed rock products that can be sifted to provide several grades of material, and are available in several colors. Others make their own by sifting crushed rock or paver sand. Acrylic washes can be used to color ballast. Two reliable suppliers of real rock ballast are Scenic Express and Arizona Rock and Mineral.



contents



index

Rio Grande Dan brought up a couple more good points. Ballasting is tedious and labor-intensive. Only work on about 18-24 inches of track at a time. Prepare your glue and wetting solutions in quantity so you don't have to stop mid-project. Stir the mixtures to blend them; shaking introduces air bubbles that will cause gaps in coverage.

Carefully apply ballast to the desired profile with a spoon or small scoop, then shape it with a 1" paint brush, foam brush, painting pad, or a modified toothbrush. Use a mister (sold for misting plants, or spraying olive oil) to dampen the ballast with a 50/50 mix of isopropyl alcohol and water. The key word is "damp." Soaking the ballast will wash it away. Apply the glue mixture with an eyedropper or syringe. Thin glue mixtures can also be applied with a hand-pump spray bottle, or a reused contact lens solution bottle. (Dan likes to build up the angled side profiles and glue them before attempting to apply ballast between the rails).

Go light with everything when ballasting around switch points and drip in a compatible oil on all moving parts to keep the glue from fouling up your turnouts. While the ballast is drying, keep moving the switch points and keep the area where the tracks move clear of glue and ballast. The edge of a paper towel can be used to wick moisture away from pivot points and throw bars.

The wetting agent and glue have to be applied gently or they will wash away your carefully arranged ballast. Big spray bottles are too powerful. Glue should be dribbled in slowly and allowed to flow through the ballast, not poured or dropped.

Resist the temptation to fiddle with the ballast until it is completely dry. Messing with wet, sticky ballast will only cause problems. A Dustbuster or a low-power vacuum cleaner with a clean filter bag can pick up the excess for reuse, after the ballast dries.

Charlie Duckworth points out that even with the wide variety of commercial ballast available, it rarely matches well enough to satisfy people modeling from photos of the real thing.

“The Mopac branchline I model was originally ballasted with cinders,” Charlie said. “When I first started putting them down I didn’t like the stark blackness so I did two things. I added a little brown and gray ballast, and I add a few drops of my acrylic dirt color in the glue mix, which tones down the black cinders and blends with the surrounding dirt color on the layout. Last step is to sprinkle a little ground foam over the ballast to denote a few weeds growing up between the ties.”

Charlie’s central Missouri Ozarks can be seen at mopac51.tripod.com and in “Model Railroad Planning 2010” from Kalmbach.

For people who don’t want to deal with the fumes from alcohol, Cajon Pass John reports good results dampening the dry ballast with just water and the Super Wet additive from Scenic Express in a dollar shop hairspray mister. Peter F. uses Rain-X for the same purpose.

You can read the original Model Railroad Hobbyist Forum thread on ballasting techniques at: mrhmag.com/node/2436.

– MRH

Q. Out railfanning, I saw a square sign with yellow and red diamond shapes stuck into the roadbed. What are these for?

A. The yellow-red sign is one of several temporary or permanent signs that instruct train and engine crews. Yellow-red is covered by Rule 12A (in the Union Pacific’s May 1, 1972 rule-book and many others), which says:

[... On to next page of text →](#)



contents



index

ROADWAY SIGNS

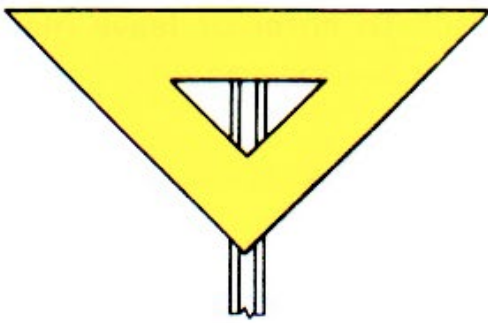

ONE MILE TO YARD LIMIT
RULE 93

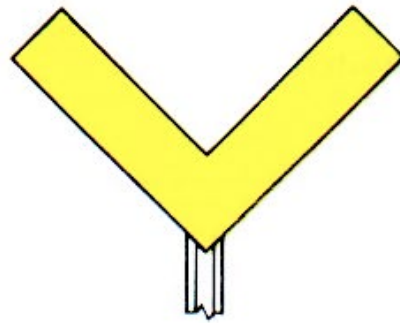

YARD LIMIT
RULE 93



REDUCE
SPEED
RULE 12(D)



RESUME
SPEED
RULE 12(D)

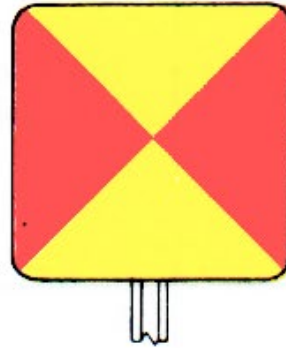

YELLOW-RED
FLAG ORDER
RULE 12(A)

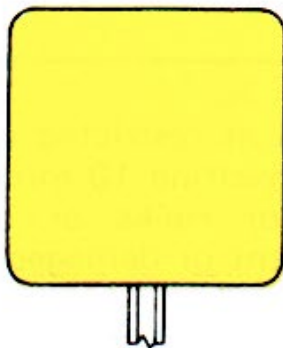

SLOW ORDER
BEGIN RESTRICTION
RULE 12(B)

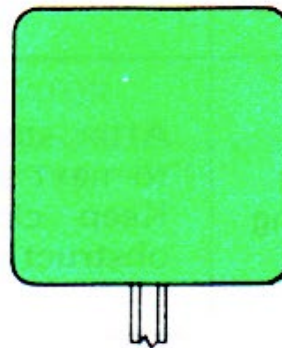

END RESTRICTION
RULES 12(A) 12(B)

[← back to previous page of text ...](#)

“A train or engine finding a yellow-red reflectorized sign displayed to the right of the track as viewed from an approaching train, must proceed prepared to stop for a red flag or a red light two miles beyond the yellow-red signal.

“In the absence of a red signal at that location, train or engine may proceed but move prepared to stop short of men or machines on or foul of track without flag protection until proceed signal given with yellow flag or yellow light is received or proper verbal information is received from employe in charge, or rear of train has passed a green flag or green reflectorized sign displayed to the right of the track.” (2)

– MRH



TIPS

Printing new windows

I purchased a used building with windows that were supplied by the manufacturer, but the fellow who put the kit together did not pay attention to alignment. As a result, the windows looked really bad. I was not able to order a replacement glazing sheet so I went to my free Open Office software and used the “Calc” program to create windows.

The “Outline” function allows you to create a border around a cell or multiple cells on a spreadsheet. I then adjusted the size

[... On to next page of text →](#)



contents



index

HO GG-1 Electrics



Now In Stock At Your Local M.T.H. Authorized Retailer

Available In EIGHT Different Paint Schemes!



80-2149-1 Pennsylvania GG-1 Electric with Proto-Sound 3.0

Featuring:

- Sound-equipped versions with built-in DCC decoder
- 2 Cab Figures
- LED lighting
- Powerful 5-pole 12-volt DC motor
- Available In 8 Different Paint Schemes
- 28 DCC Functions*
- Kadee® Couplers
- Remotely Operated HO Scale Proto-Couplers
- RP-25 Metal Wheels Mounted on Metal Axles
- Lighted Cab Interior
- Illuminated Number Boards
- Lighted Marker Lamps
- Locomotive Speed Control in Scale MPH Increments
- Operates On Code 70, 83 & 100 Rail Curves

** Proto-Sound 3.0 Equipped Models Only*



Follow Us Online!



See why
M.T.H. HO Locomotives
Do More



©2012 M.T.H. Electric Trains



[← back to previous page of text ...](#)

of each cell until I created a cell which matched the window needed. I was able to adjust the size of the window dividers by changing the line size and could also change the color. The “Border” dropdown menu lets you select the line width and the line color. I printed a test sheet to check against the window opening and made the necessary adjustments to the cell size.

When I was satisfied, I saved the file as a .pdf to a flash drive, then went to my local Office Max and they were able to print the windows on a clear acetate for me. Also I save the “drawing” so if I need more of the similar size windows, all I need to do is go back to the local office service company and have more printed.

– Thom Vanderlip

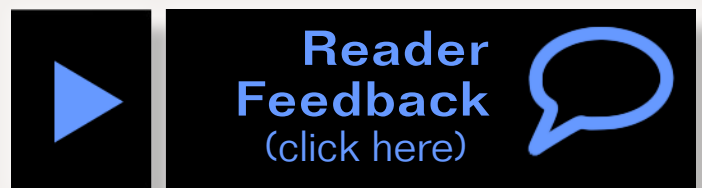

GET \$25 PER TIP

We pay \$25 USD for each tip we publish.

[Send your modeling tips to Model Railroad Hobbyist](#) and we'll get payment to you upon acceptance.

Just think, for only a few minutes effort, you could fund your next piece of rolling stock – or even pay for an entire train if you send in several tips and we publish them!

If you include any photos with your tip, we pay a bonus of \$10 per photo we use with the tip. ■



contents



index

A Landmark Book-Five Years in the Making

DELAWARE & HUDSON BRIDGE LINE FREIGHT 1960-1983

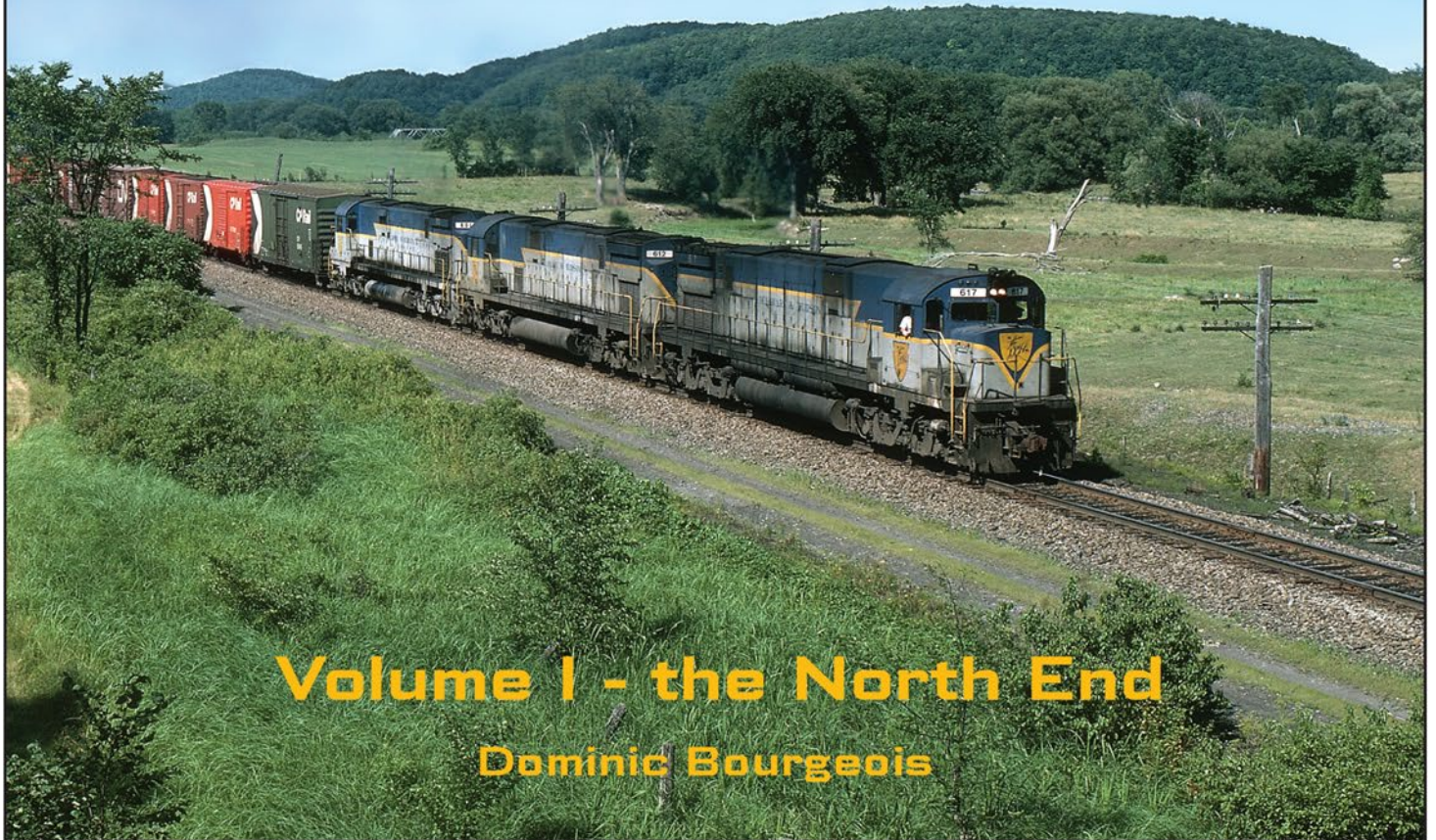

Volume I - the North End

Dominic Bourgeois

Delaware & Hudson, Bridge Line Freight 1960-1983 takes the reader on a journey along one of America's most photogenic railroads, examining D&H facilities, overhead traffic, on-line customers and local and through freight operations, during the most colorful period in the railroad's history.

From the fertile farmlands along subsidiary Napierville Junction, to the scenic splendor along Lake Champlain and into the Adirondacks, to the gritty industrial back streets of Albany, the D&H is examined like never before!

- Hard cover with gloss dust jacket. 180 all-color pages. Maps.
- Over 250 never-before-published color images from 30 photographers.
- Made and printed in New Hampshire, U.S.A.

Preview the book here!

www.railroadexplorer.com



Email



Phone



contents



index

iwata

by ANEST IWATA

Just Rolling By...

Make It **REAL** With Iwata *Climb Aboard!*



**Eclipse
HP - CS**

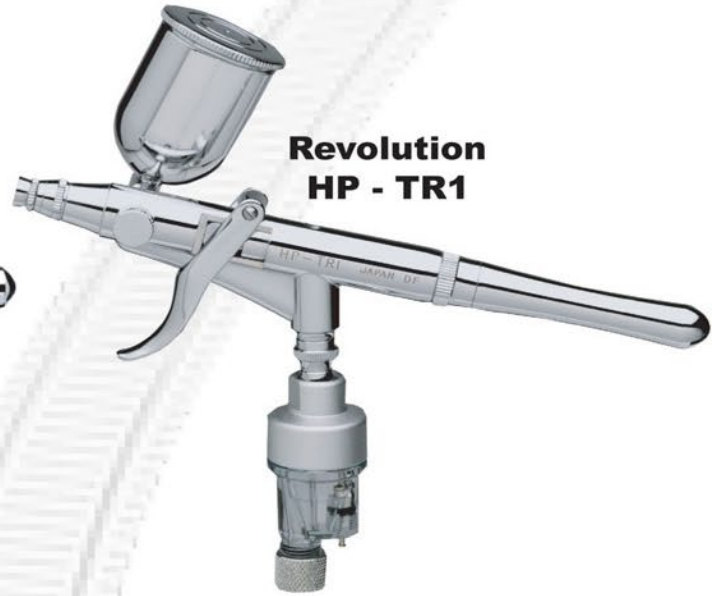

**Revolution
HP - TR1**

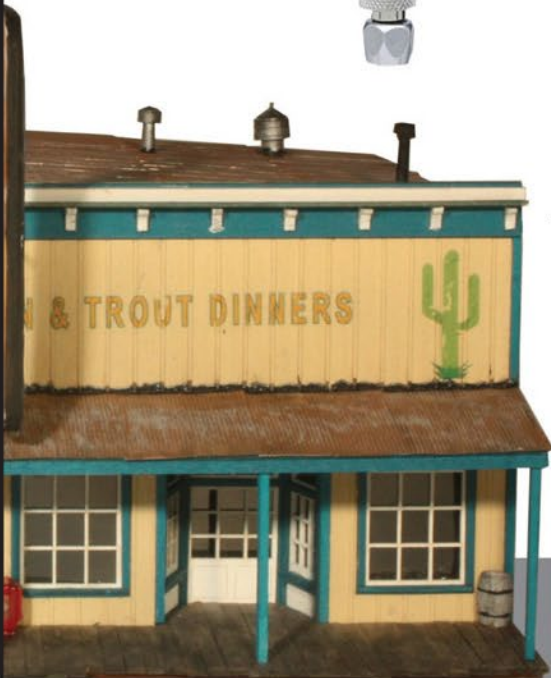

Visit... www.iwata-medea.com **To Check Out Our Full Product Line!**

*Models By... Alan Houtz,
North American Prototype Modelers*



contents



index



DCC Sound

HO Kato NW2 Sound Installation



DCC Impulses column

by [Bruce Petrarca](#)

How to make this switcher sing, plus a look into my techniques ...

Welcome to my first column in the new Gen 2 format for MRH. Hopefully, you will find your reading experience better than you did with the old format, regardless of your reading platform.

This month's "*From Mr. DCC's Workbench*" sidebar discusses the long awaited NCE PowerCab upgrade (version 1.65).

The Kato HO-scale NW2 is a popular loco. There were lots of prototypes and the model runs like a top! However, it is a DCC nightmare. In my "*DCC Ready? The Good, The Bad and The Ugly!*" clinic, it is high on *The Ugly* list.

Here I'm going to discuss a sound installation into this loco. While this column targets this specific HO loco, the techniques I'll be demonstrating apply to all sorts of locos:

- Locos with split frames (two frame halves that are insulated from each other, but connected to the respective rails) in any scale

- N-scale locos are frequently split frame design. Also, this loco has many common parts with Kato N-scale locomotives.
- My cleaning and lubrication techniques cover a wide range of locos.

This column is based on a lot of information presented in my earlier columns, specifically

Wired Decoder Installation: January and February 2012:

mrhmag.com/jan-2012-dcc-impulses

mrhmag.com/feb-2012-dcc-impulses

The videos in column allow you to look over my shoulder while I do this installation. I worked to show and explain what I was doing along the way. I hope you'll find it a useful tool.

I recommend the HD version, as the details may get lost on the SD version. The numbers in the headings in this column refer to the sections of the video. This column plus the video is a "must have" for anybody installing DCC into split-frame locomotives.



1: Kato HO-Scale NW-2 loco painted for our club's road (pcmrc.org).



contents



index

A DCC installation in any split-frame non-DCC-ready loco requires complete disassembly of the loco, frame machining, motor isolation and reassembly.

For years, I've had folks asking me to install sound in these NW2s. I've not been happy with any of the ones I've tried. Non-sound installations have been very successful, but difficult to do.

Part of what makes this a great switcher is what causes the installation issues. The entire loco interior is weight. It has a lot of traction.

Over the years, I've become comfortable with putting a small DCC decoder in the cab floor, as shown in (2). A cable relief needs to be cut into the frame (upper left in the photo). This

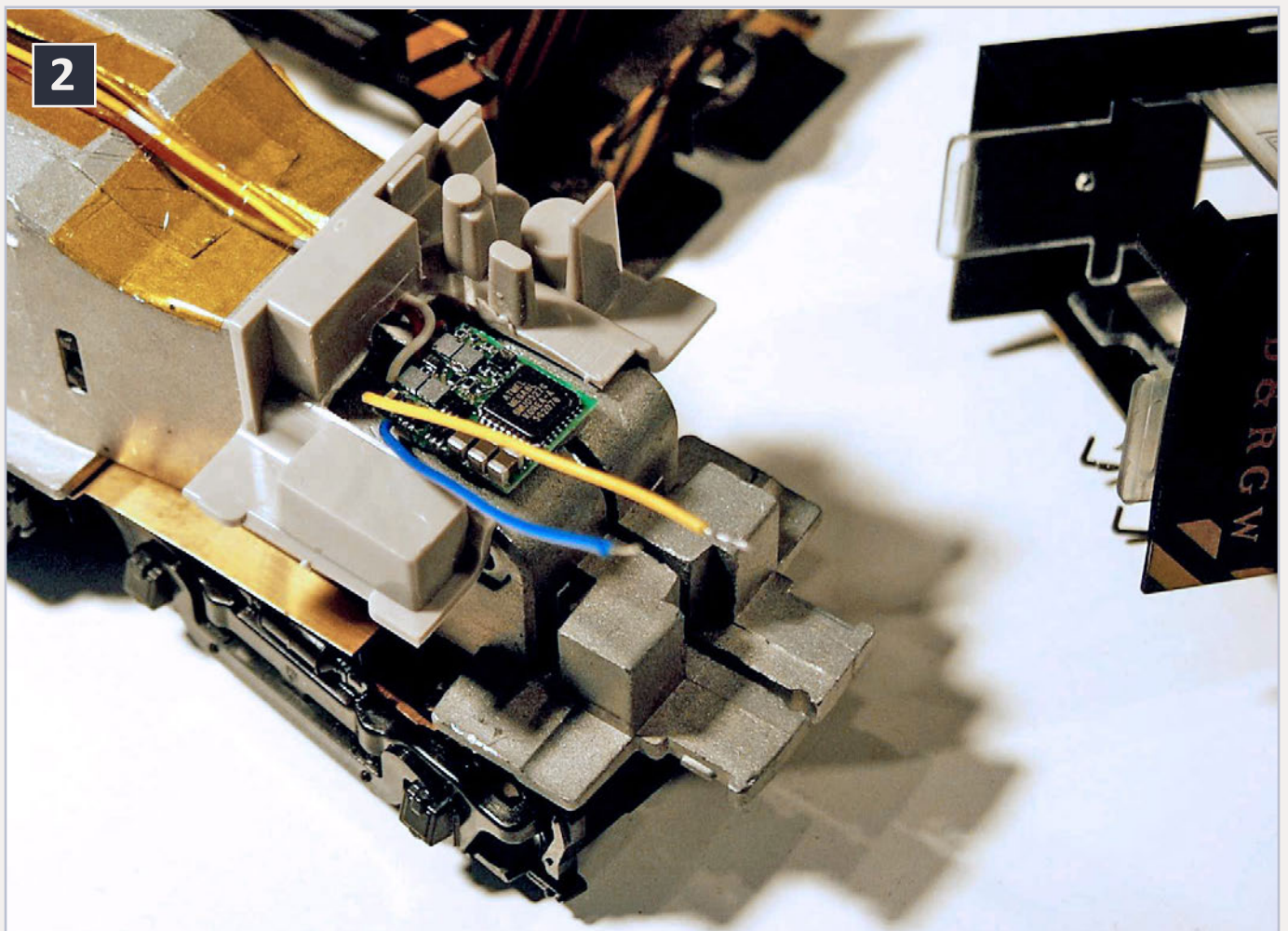

2: Kato HO NW2 ready for final assembly with a non-sound decoder.

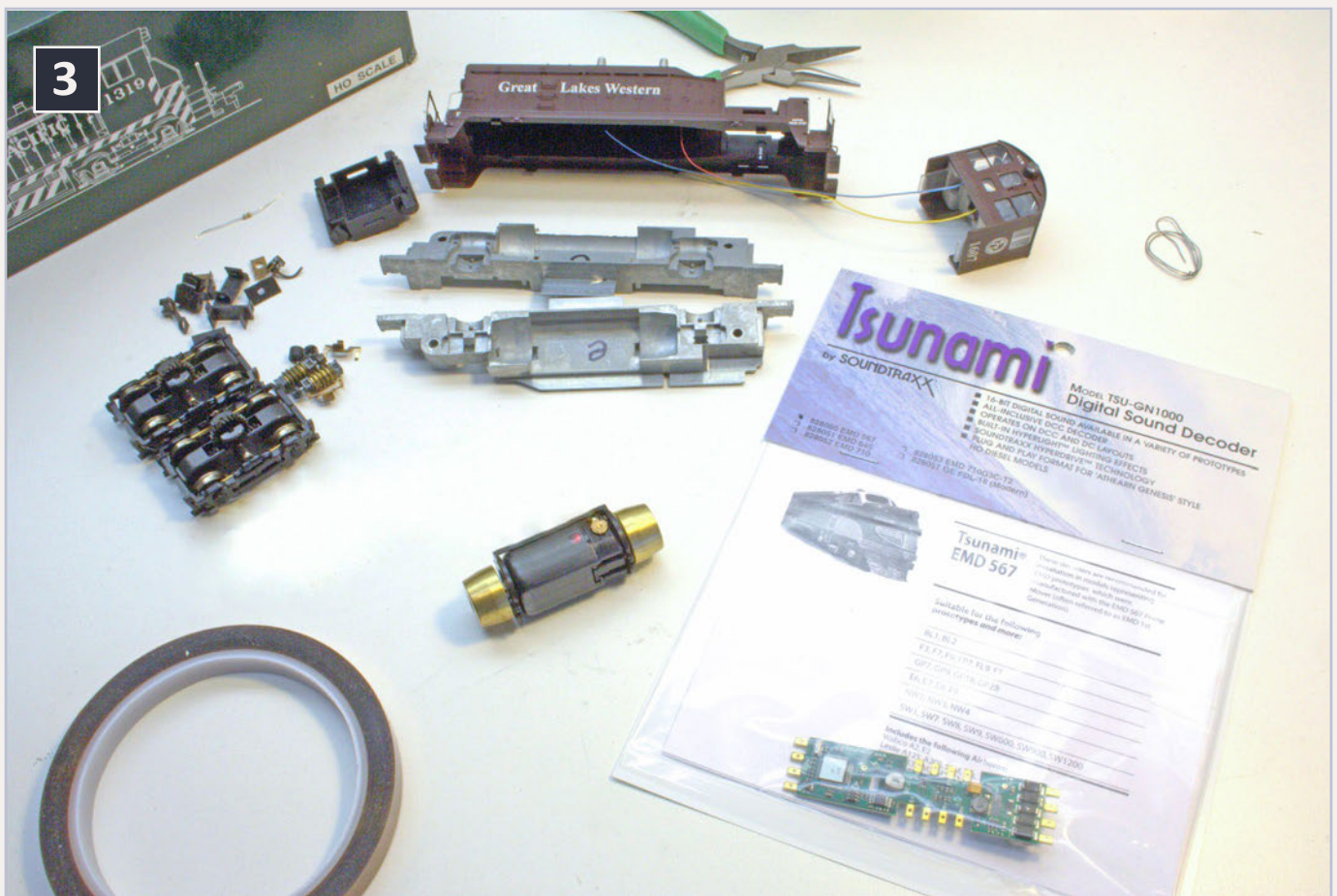

3: HO scale Kato NW2 ready to reassemble with Tsunami decoder.

can be done with a mill or belt sander. The photo also shows some of the cab floor removed to have a place for the decoder.

Early in 2012, I found installation notes on the web from George at TVW Miniatures (mrhmag.com/url/tvw-nw2). His approach appeared to have merit. Since it uses a small (N-scale appropriate) speaker in a small enclosure, I didn't have hopes for room filling sound. When the loco was done, I was pleasantly surprised to find that it had a reasonable sound from a Tsunami GN series decoder. Since it is a yard switcher, this localized sound is fine.

I had George machine the frames for six of these units and what follows are notes, photos and video from assembling these locos. Some had DCC installed previously, as shown in (2), so



contents



index

some cab repair was needed, too. Don't be confused by the different locos in the photos, ok?

You may want to contact George about machining your frame before you start. Together you can work out details. Contact him at mrhmag.com/url/tvw-contact.

The locomotive disassembled and ready to start reassembly is shown in figure 3. If you don't feel confident building a locomotive from this starting point, I suggest you don't want to even get started on this installation. Have a professional do it!

1.0 First steps

Before you can remove the shell, you need to get the couplers out.

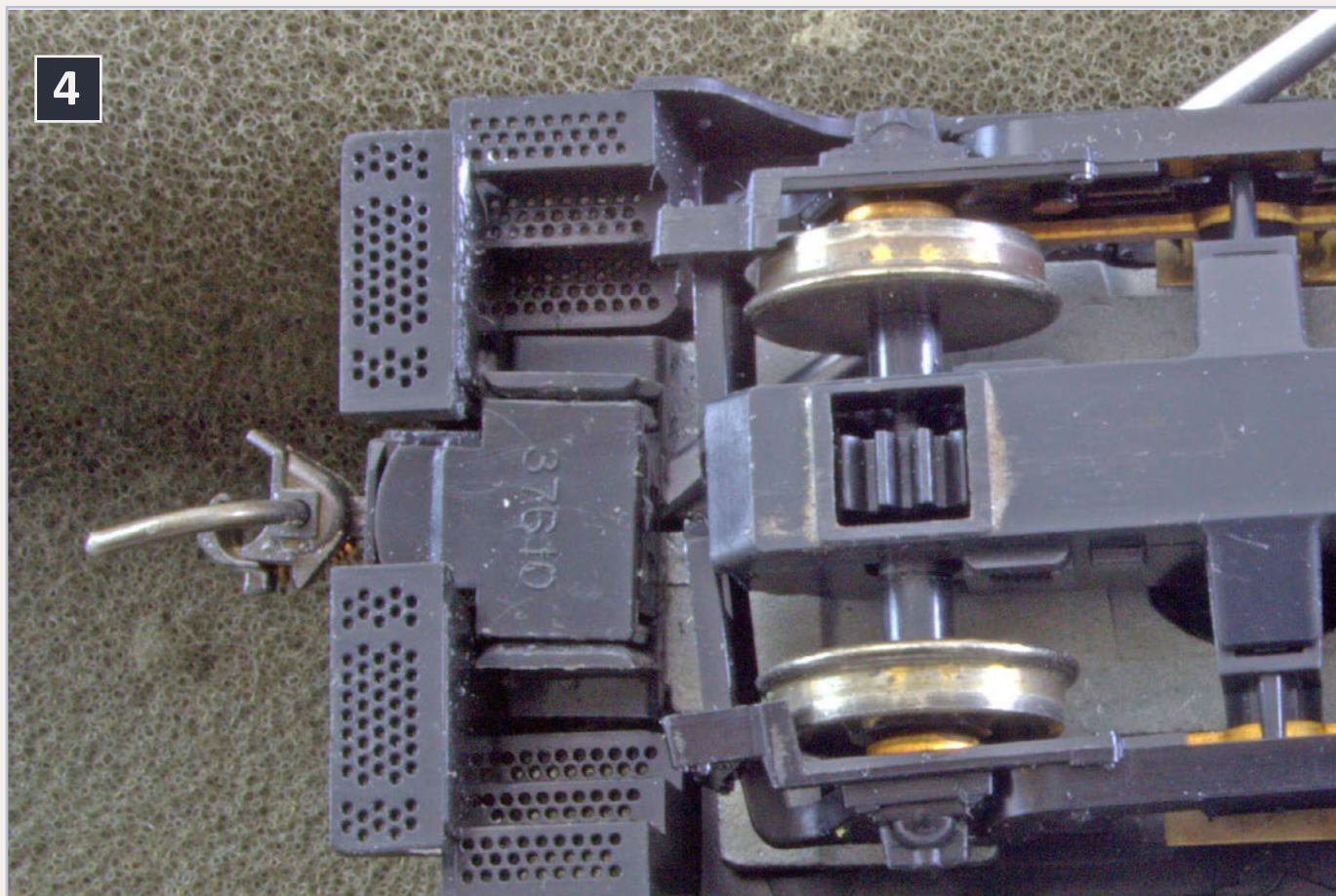

4: Pry coupler loose from frame with a flat screwdriver.

5: Video showing coupler removal.



Playback problems? [Click to try a different version.](#)

1.1 Coupler removal

The approved way is to snap the top off the coupler box; remove the coupler and spring; then remove the (upper) box holder.

I prefer to take them out in one piece, as shown on my video (5). I cannot provide a ready 1, 2, 3 method to do this. There is not enough clearance around the coupler box to directly remove it. It needs to be encouraged to twist and turn until it comes out.

Pop the coupler mount off the frame with a screwdriver (4) and then just worry the entire assembly out of the loco, working it past the pilot steps and the truck mechanism.



contents



index

Store the parts in a container for reassembly. You will understand why I prefer to remove the entire assembly at that time.

Figure 5 is an excerpt from the full-length video showing how to remove the couplers.

1.2 Separate shell from frame

Slide the fuel tank shell off and set it into the storage container.

The shell is just a friction fit on the frame. Once the couplers are removed, a screwdriver can pry between the frame and the shell to get it started (6). There is a metal tab on each end of the loco to pry GENTLY against.

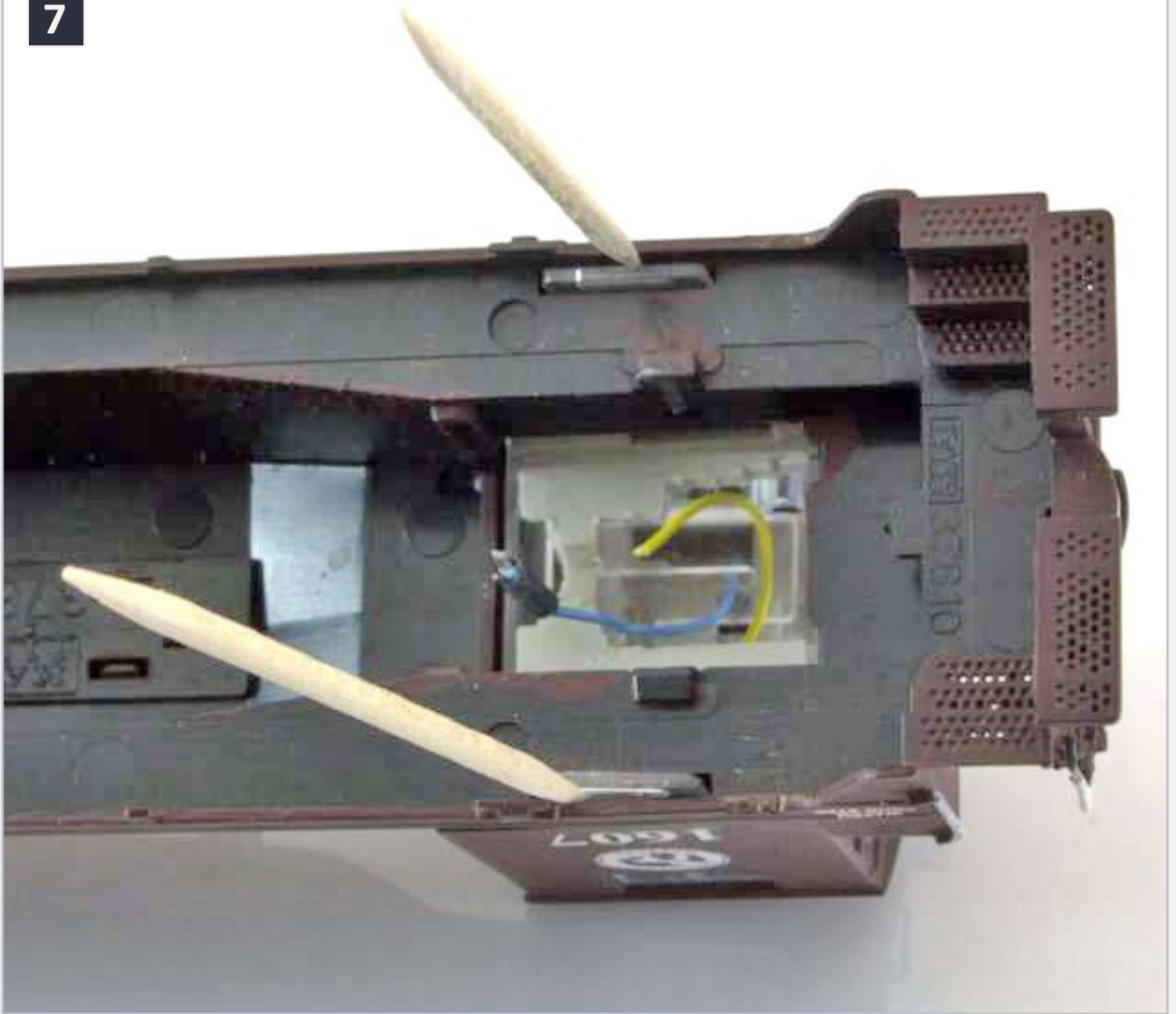

6: Prying the shell off the frame.

7

7: Insert toothpicks to remove cab from shell.

Once you have the separation started, just pull straight up on the shell. It should slide off the frame. Be aware, if the loco already has had a DCC decoder installed, there may be wires between the shell and the frame to power the rear light. For the ease of following steps, I recommend cutting these wires as far from the decoder as possible.

1.3 Remove cab from shell

The next step is to remove the cab from the rest of the shell. If the railings are installed in the rear of the locomotive, gently

[contents](#)[index](#)

pull them from their connection to the cab. Then you release the tabs that are holding the cab into the shell.

It is a simple matter, once you know where to pry. Look at the bottom of the shell assembly (7) and insert a toothpick or screwdriver between the clear plastic side window extension and the edge of the shell. A bit of coercion and the cab pulls up and away from the shell (8).

1.4 Disassemble cab

The loco was built with yellow LEDs for the front and rear lights. Newer technology allows us to replace these LEDs with “incandescent” white LEDs. To do so, the cab needs to be disassembled. This is shown better in a video (9) than in still photos. Once again, this video is just a portion of the full length version.

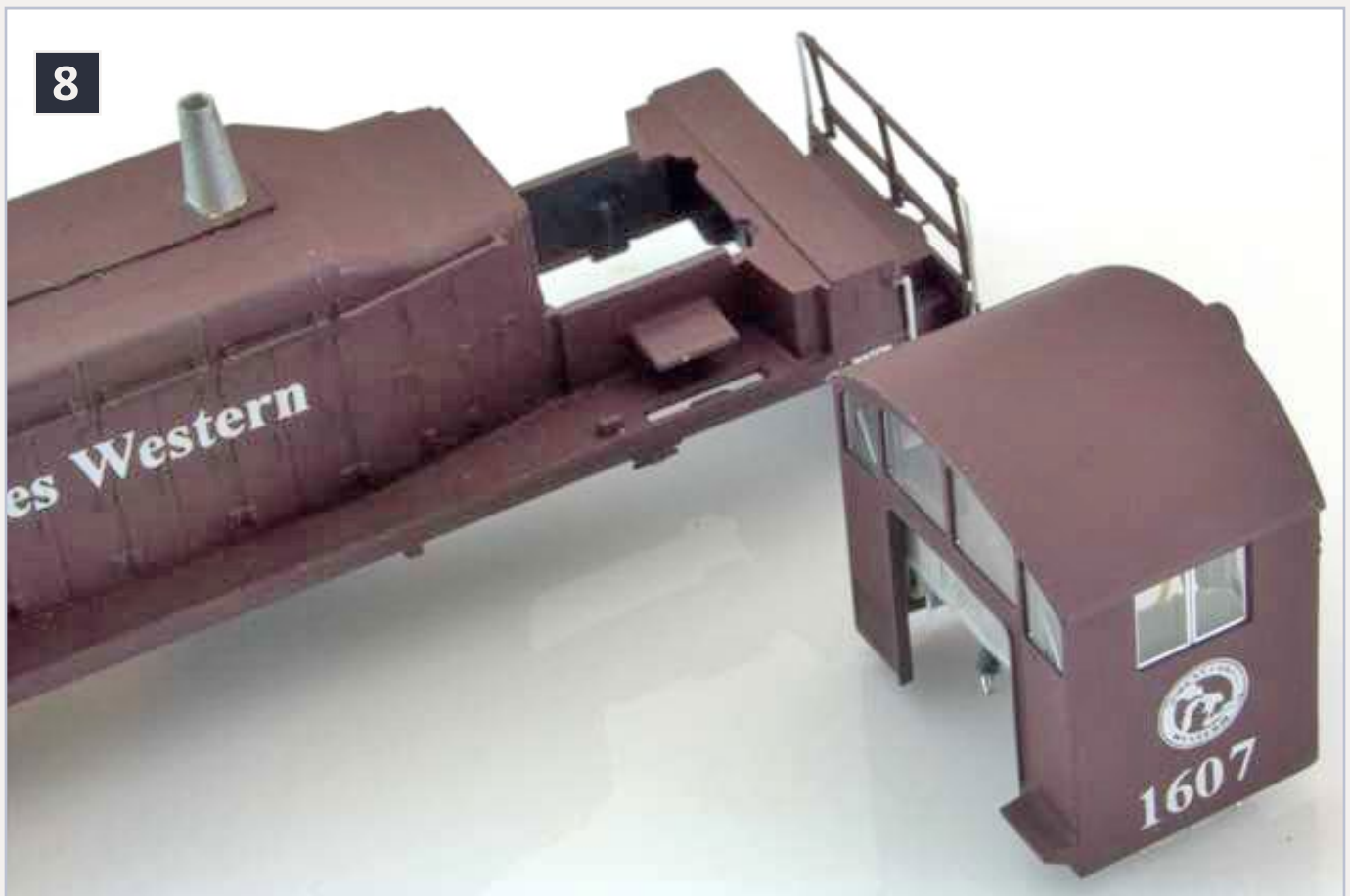

8: Cab separated from shell.

9: Video of cab disassembly.



Playback problems? [Click to try a different version.](#)

There are only a few steps, but it helps to see them done, hence the video.

- Remove floor
- Remove side windows
- Remove front and back windows
- Remove rear light assembly

2.0 Preparation

Before you disassemble the drive train, you will want to mark the motor so that the loco runs the correct direction when you hook the decoder up. If you forget to do this, you can wing it later: if the loco runs backward when you test it, you only need to reverse the connections to the decoder.



contents



index

2.1 Marking the motor

Before you split the frame completely apart, note that the top motor brush connects to the right-hand frame half (10). Mark the motor near this brush holder in some way that you will be able to use later during the reassembly process. I use a red or orange paint marker. Since this dot is on top of the motor, it tells me which way is up when I reassemble the loco.

The motor, shown in figure 10, has had DCC connected to it, so the tab had been removed. I soldered a tab in place so that you can see the idea. The tab comes toward you in figure 10 and is covered with solder. A factory fresh loco won't have the solder, just the copper parts.

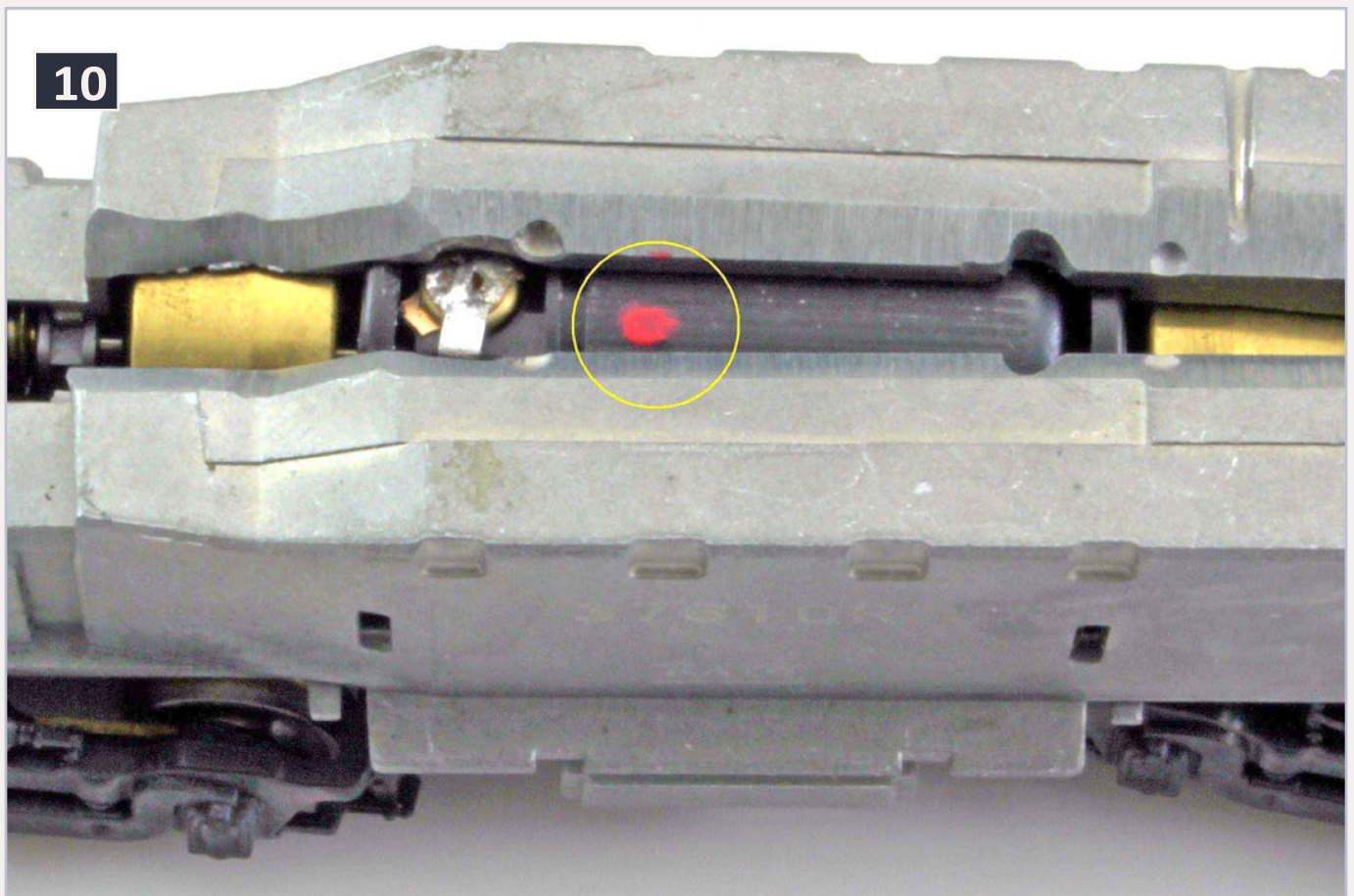

10: Marking the motor brush connected to the right rail.

2.2 Disassemble the drive train

The next step is to disassemble the “guts” of the locomotive. Here is where you will really appreciate the details on my video (see photo 11).

Corral the parts in a box or something that can be covered, especially if you are sending the frame off to be milled and won't be reassembling the loco in a few hours.

- Remove the copper pick-up strips and the headlight board. They will not be used in the final loco assembly.
- Remove the screws and nuts.
- Split the frame slightly and mark the motor as explained in section 2.1
- Set the trucks aside. Some folks like to mark front and rear trucks for reassembly in the same location. I haven't seen much variation in these locos; so I don't worry about it, at least with this model.
- Remove and store the pieces of the drive train – don't overlook or lose the adapter bushings inside the flywheels.
- Remove the insulating bushings from the frame halves.
- Remove the (copper) bearing retainer clips from the right frame half.

You should now have two pieces of gray metal (the frame halves) with nothing on them. Now is a good time to use some denatured alcohol and a stiff brush and some Q-tip(s) to clean the frame halves of built-up lubricants and dirt.

The frame halves are ready to be machined.



contents



index

3.0 Preliminary Assembly

My next step is to install the new lights in the shell. This way, the glue can be setting up while you are doing other tasks. If you send the frame halves to George for machining, it will be a few days to a couple of weeks before you have them back to reassemble the loco. If you machine the frame yourself, count on a few hours work in the shop, see section 4.

3.1 Rear light

Find the rear light assembly you removed from the cab. The rear light assembly comes apart by pulling the circuit board out from the gray plastic housing.

Remove the copper strips, the 270-ohm resistor and the yellow LED from the board. Install a 750-ohm 1/4-watt or 1/8-watt resistor and a Golden White 3 mm LED from Richmond Controls. Don't worry about polarity on either item at this point. The resistor has no polarity issues and we'll determine the LED's polarity later.

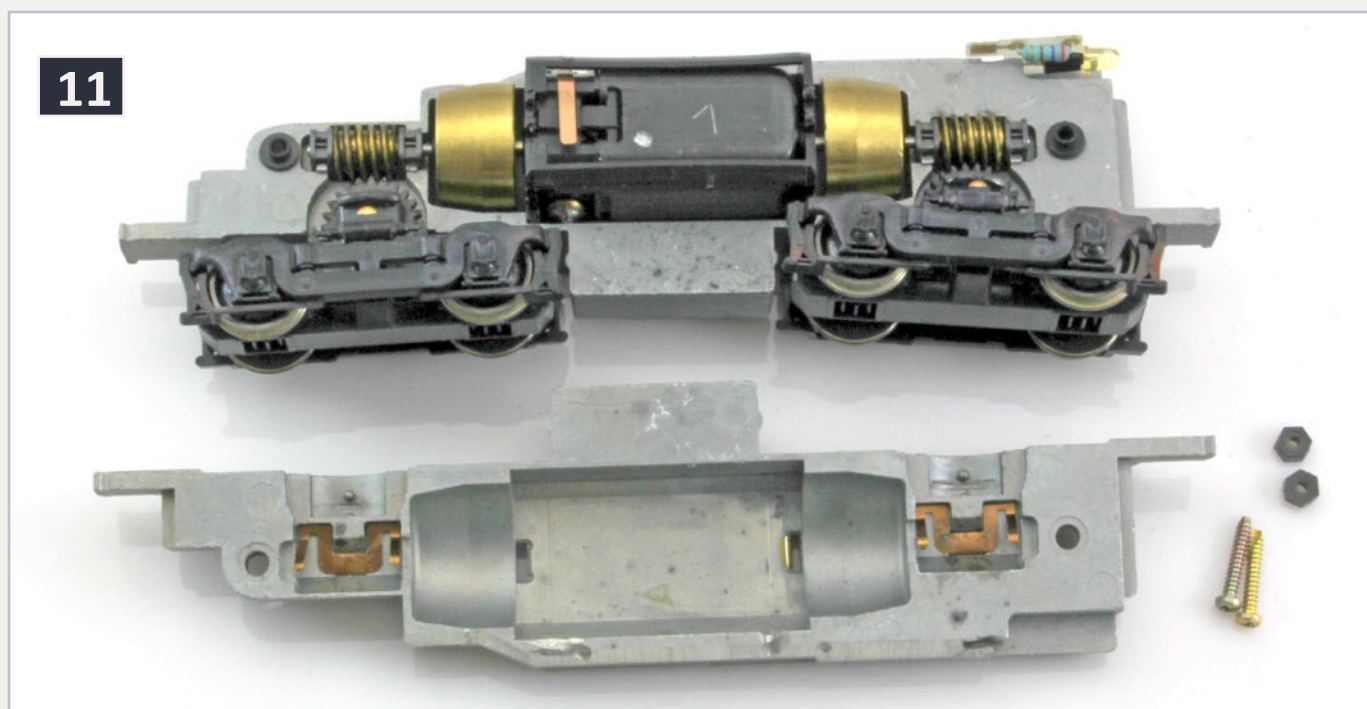

11: The frame halves split before drive train removal.

12

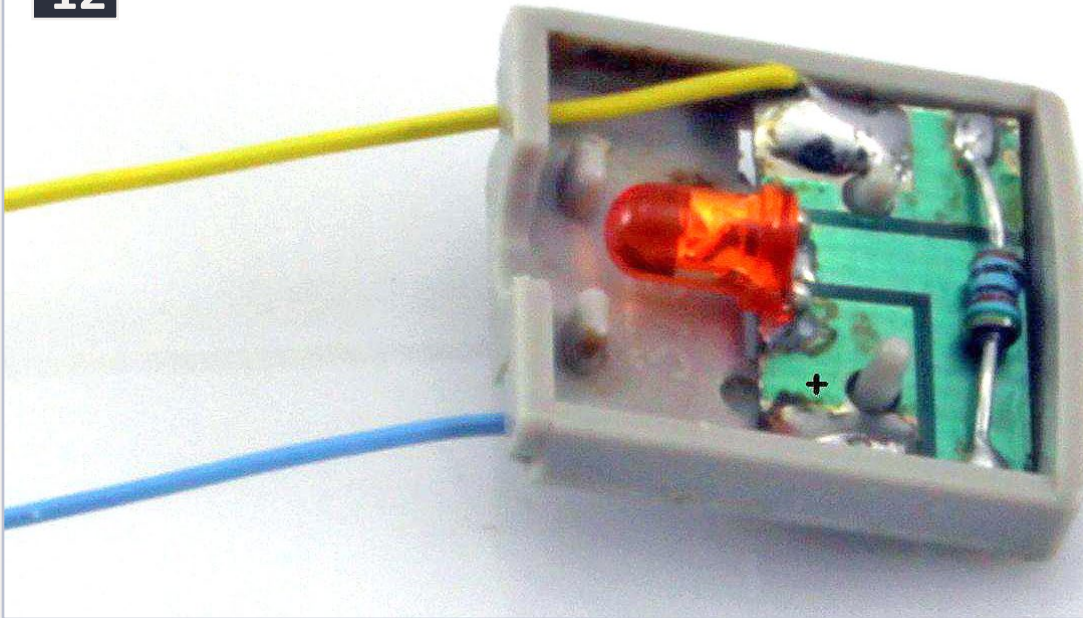

12: Rear light assembly with blue wire tab marked (+).

I selected the Richmond Controls Golden White LED for the rear to have a color balance with their SMD LED in the headlight.

Once the LED and resistor are in place, I use a 9-volt battery to test for operation. With one polarity, the LED should light. With the opposite polarity, it should be dark. Note or mark the tab that is connected to the positive battery lead when the LED lights (12).

Install about 6 inches of blue wire to the tab that was positive when the LED lit. Install about 6 inches of yellow wire on the other tab. I used the 30 AWG wire from TCS.

Route the wires out through the gray plastic holder (12). Save this assembly for use when the loco is put back together.

3.2 Front light

I selected a Richmond Controls Golden White SMD LED for the front light, as it saves valuable room inside the loco. Now is the time to install that LED, so that the glue can dry. Richmond sells



contents



index

them with a 6-inch long set of wires connected, so there is no fancy soldering needed to get wires on the LED.

I like to connect the LED to a buzzer (9 volt battery and buzzer combination) that limits the current through the LED and allows me to view the light, as I'm installing the LED. For information on the buzzer, see my January 2012 column (mrhmag.com/jan-2011-dcc-impulses).

One of the best-kept secrets in model railroading is Formula 560 Canopy Glue. This glue is well known to the RC plane folks. They use it hold the canopy onto their planes, hence the name. It bonds almost anything and dries clear. I've even made windows out of it. It also dries quickly, so I use it instead of white glue for wood structures, as you can slap things together quickly and they will hold their shape. It will take 24 or more hours for the glue to be fully cured, hard and clear.



13: Front SMD LED held in place with blue tape while Canopy Glue dries.

A piece of blue painters' tape holds the LED in place by its wires in the top of the shell. Slide the LED into place and observe that it is positioned to shine out through the lens. Then put a drop of Canopy Glue to hold it in place, as in figure 13. Set it aside to dry for at least a few hours before working on the shell again.

3.3 Fix Cab Floor

Several of the locos I did in this batch had had DCC decoders installed previously. The cab detail floor had been cut away to provide a place for a very small decoder to reside. I fixed the cab floor by cutting a piece of 0.02-inch thick plastic (black, in this case) to fit over the hole. I glued it in place and spray painted it with Krylon gray primer. You will only need to do this if your loco has had the integrity of the cab details damaged in a prior installation. Set it aside to let the paint dry. We won't use it until the final assembly. See figure 14.

4.0 Machine frame

The key to this installation is to get enough room in the frame for the decoder, speaker and wires. This requires a bit of fancy milling. George at TVW Miniatures (mrhmag.com/url/tvw-nw2) designed this version and offers frame machining services. Even though I have a mill, I had him do the machining. Kato no longer has stock of the frames, so if you mess up your frame, you may never get your loco back running.

If you are going to machine them yourself, there are dimensions on my web site (mrhmag.com/url/mrdccu-nw2).



contents



index

5.0 Wire motor

Okay, we are through tearing things down. Time to start putting them back together.

First we will isolate the motor and attach wires to it. More TCS 30 AWG wire is needed, this time in gray and orange.

The trick in isolating the motor is to get the copper clip that connected the motor to the frame half off and a wire soldered onto the brush cap without melting the motor body. There are two ways to do this:

1) Remove the brush holder from the plastic motor housing – pry it up with a flat bladed screwdriver, without loosing the parts inside. Remove the copper contact strip. Solder the wire to the cap of the brush holder. Reassemble the brush unit into the motor. The upside of this is that you have the brush holder out of the motor and cannot melt the plastic frame. The downside is that you have to keep track of the brush holder, the cap, the spring and the brush and reassemble them correctly.

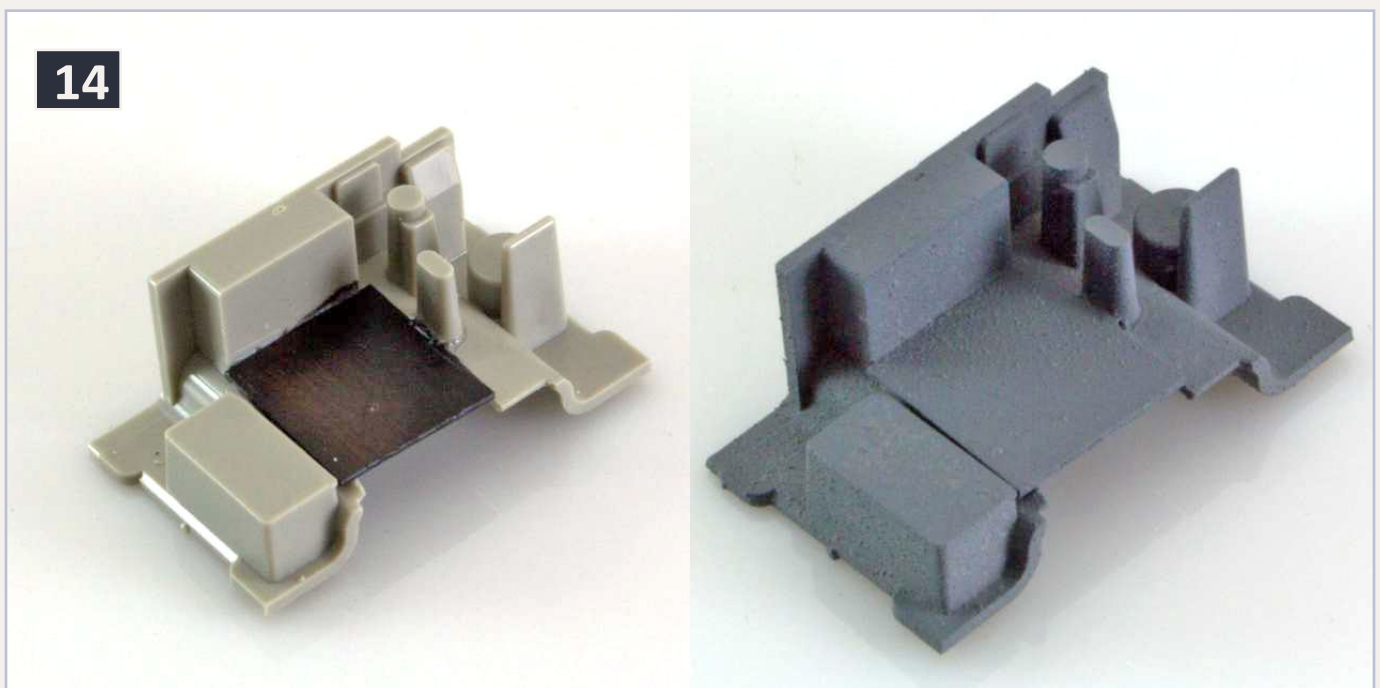

14: Cab floor replacement and painting – repairing damage from prior DCC installations.

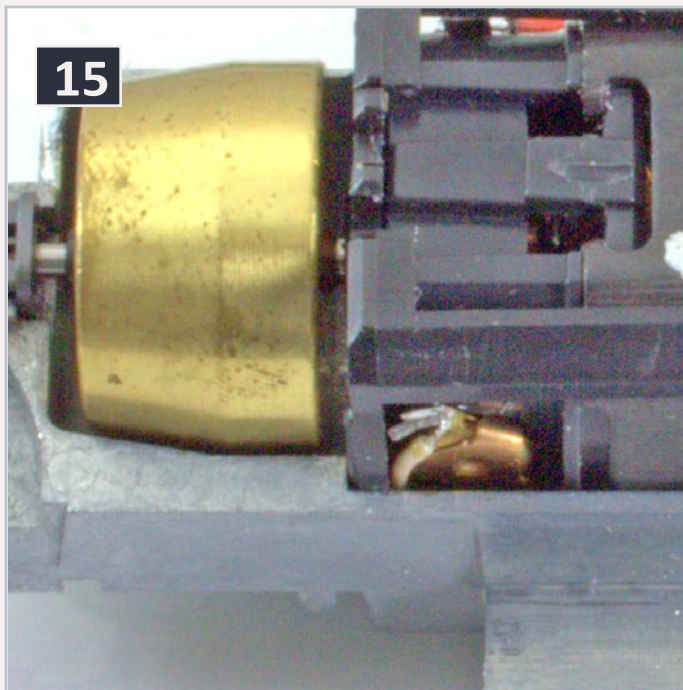

15: Motor wired, sitting in the left frame half.

2) Cut the copper strip off as close to the brush holder as you possibly can and solder quickly to the brush cap. Advantage: don't have to chase a bunch of parts and rebuild the motor. Disadvantage: good soldering technique is necessary to keep from melting the motor frame. If you cannot solder feeder wires to your track without melting ties, I suggest you don't try this at home.

Wire the orange wire to the top (marked) brush. Connect the gray wire to the bottom brush. Cut the wires to about 2 inches long. Figure 15 shows the motor reassembled into the frame so that you can get an idea of how the wires will eventually be routed. Note that the plastic frame clip is positioned to help keep the wires and brush caps from contacting the frame halves.

6.0 Assemble drive train

The next step in reassembling this loco is to put the drive train back together. However, at this time we have all of the parts out of the loco. It is a perfect time to clean and lube the loco.



contents



index

While we are doing all this, why not bring it into this millennium with technology?

St. Claire's Nano-Oil is a Model Railroad Hobbyist sponsor (mrhmag.com/url/nano-oil). They offer high-tech oil designed to minimize friction, reducing running current and make low speed operation more reliable. Well, with a switcher, what is more important than low speed operation? In order to take best advantage of the Nano-Oil (16), first the existing lubricant and debris must be cleaned out.

I was initially skeptical about the claims about Nano-Oil. However, my experiments have shown significant improvement in low speed operation. You are gonna need to lube it with something, why not go for the best? For this installation, I used only the 10- and 85- weight Nano-Oil.

[... On to next page of text →](#)



16: Nano-Oil, available in easy applicators in three weights.

**New
Innovation**



Nano Technology Lubricants

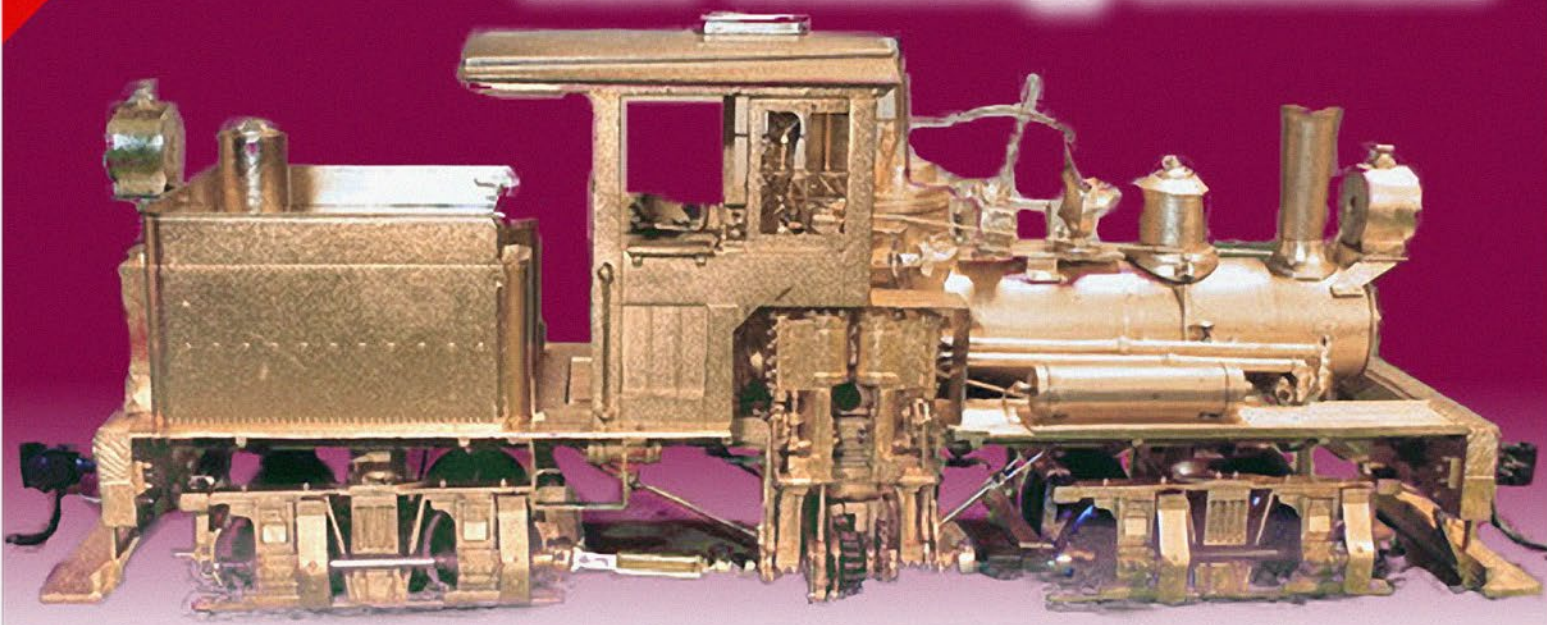

"I was skeptical, but my experiments show significant improvement with Nano Oil ... why not lube it with the best?"

- Bruce Petrarca, MRH DCC columnist

Nano-Grease

THE SHAY FIXER 

VISIT US AT... 
SHAYFIXER.COM

Specializing in brass Pacific Fast Mail / United geared locomotives

**For more details
click here ...**





17: Cleaning the truck assemblies with a motor tool and brass brush wheel.

[← back to previous page of text ...](#)

6.1 Clean trucks

If this loco has been used, there will probably be an accumulation of dirt and debris on the wheels. I use a brass brush in my rotary tool to clean the wheels of the trucks before reassembly, as shown in figure 17. I use my finger to limit the rotation of the wheel assembly, while the motor tool is trying to accelerate the wheels. The difference in speed between the brush and wheel allows the brass brush to remove or loosen debris on the wheels and polish them. Then, I use a Q-tip soaked in denatured alcohol to remove the remainder or send them through the ultrasonic cleaning explained in section 6.2.

If this loco is brand new, the wheels will be blackened overall. This brass brush technique will allow you to remove the blackening and expose new metal, making the electrical connection between the wheels and track more reliable.

6.2 Clean the drive train

I took the drive train parts and the truck assemblies and immersed them in a degreasing solution and ran them through

my ultrasonic cleaner. My formula for the degreasing solution is half isopropyl alcohol and half water. To this mixture I add about 10% (an ounce to a cup full) Simple Green degreaser. I fill the ultrasonic cleaner bowl with water and put the parts in a stainless steel cup with the degreasing solution. I float the cup in the ultrasonic cleaner and run one 3-minute cycle. I examine the parts. If they still have grease and dirt hanging on, I send them through again. When they seem pretty clean by inspection, I finish them off, using my fingernail and a paper towel, as well as a stiff acid brush to clean them. When they seem clean to the eye, I rinse them and allow them to dry – overnight, if possible.

6.3 Reassemble the drive train

Once the parts are clean and dry, I reassemble the drive train. I put a drop of 10-weight Nano-Oil on every sliding surface: the bearings, the worm gear and the motor bearings. I assemble



18: Cleaning drive train parts in ultrasonic cleaner.



contents



index

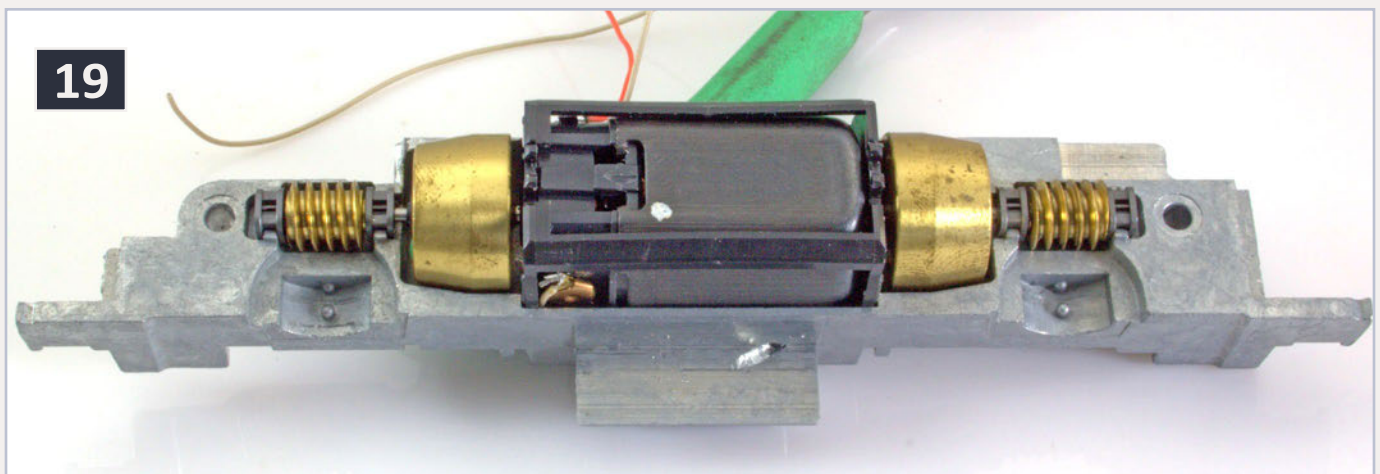

19: Drive train reassembly ready for trucks and insulators.

the worm gears, the adapter sleeves and the motor into the left frame half, as shown in figure 19.

6.4 Position motor wires

The motor wires need to be routed out the top of the frame in such a way that they won't be cut by the frame. The wires need to be positioned so that they won't contact either frame half. See figures 15, 19 and 20. If you have any questions, use a piece of Kapton tape to prevent a short. The motor in figure 19 didn't have any clearance issues. The one in 20 might, so I used Kapton tape, just to be sure. After the photo (20) was taken, the motor mounting clip was rotated around the motor shafts until it was in the position shown in figure 19.

6.5 Assemble frame halves and trucks

The next step is to put the cleaned trucks into the left frame half and put a drop of 10- weight Nano-Oil where the truck slides on the frame.

6.6 Lightly tighten screws

Once you have the parts positioned as shown in figure 21, slide the other frame half over the drive train and tighten the

screws, very lightly. If you understand the goal of these screws, you won't over tighten them. They are to hold the frame halves and trucks together long enough for you to slip the shell over the assembly. The shell is what eventually holds the loco together. The plastic nuts won't support a lot of tension before they strip. Be gentle.

Alternatively, I'll assemble the frame halves without the trucks in place. The screws are started, but not tightened. Then the frame halves can be split slightly and the trucks slid into place. Finger pressure will hold the frame half together while you tighten the screws very lightly. Remember to put a drop of oil (21) on the frame halves before assembly.

7.0 Apply Kapton tape to top of frame

The Tsunami decoder selected for this installation is an un-insulated board. So, to prevent fatal shorts either to components on the board or our connections to the decoder, the entire channel where the decoder will rest will be covered with a layer of Kapton tape (22).

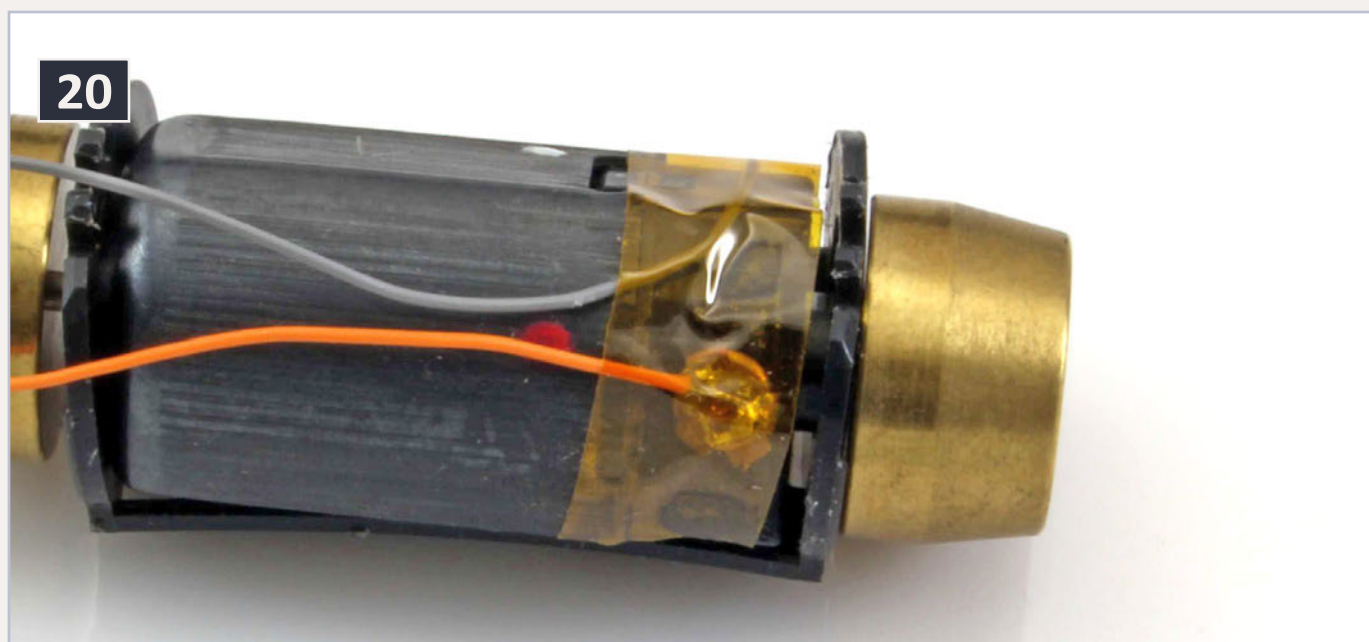

20: Kapton tape insulating motor brush contacts..



contents



index

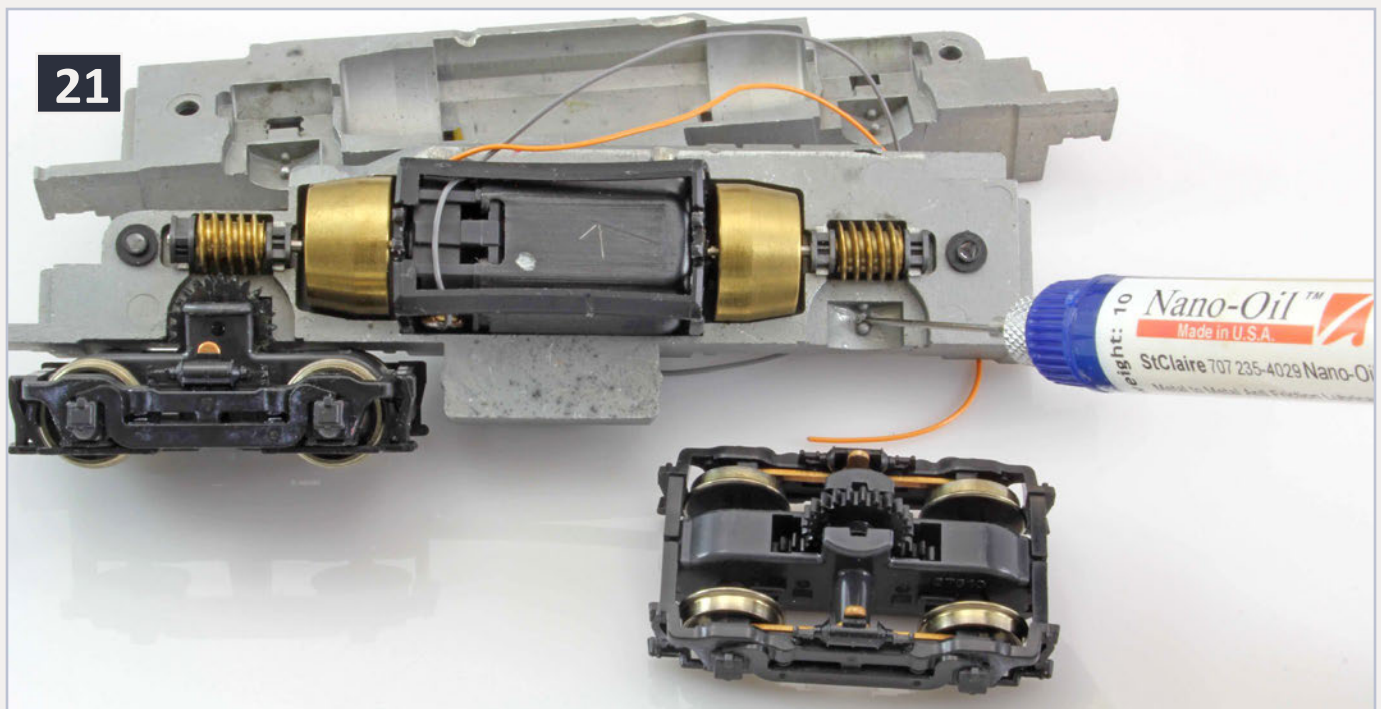

21: Lubricating the frame half where the trucks rotate.

We need to cover the entire decoder relief with Kapton tape, including the sides. I find that having multiple widths makes the job easier. One of the nice things about Kapton tape is that, being only 0.001 inch thick, it can be overlapped without excessive thickness build up.

Run 3/8-inch Kapton tape down the length of the channel on the right side. Route the motor wires over this tape and through the wire relief hole in the right front of the frame. Use blue painters tape (less messy than traditional masking tape) to secure the orange and gray motor wires out the right front cable relief, as shown in figure 22. Run a length of the 3/8-inch Kapton tape down the left side, slightly overlapping the right piece – the motor wires should emerge from the frame between these pieces of tape. Use two pieces of 1/4-inch Kapton tape, one down each of the two sides to complete the insulation of the decoder cavity.

Make hobby knife slices through the vertical tape at the cable troughs to allow room for the wires to connect the trucks and speaker to the decoder.

8.0 Install speaker into fuel tank and route wires up right front channel

Now things are moving quickly. The next step is to mount the speaker into the fuel tank relief. I selected a speaker from another Model Railroad Hobbyist sponsor, Railmaster Hobbies (railmasterhobbies.com). It is a 14 x 25 mm unit with its own enclosure – DS1425-8. The speaker enclosure is just a bit longer than the fuel tank boss on the frame.

Put some caulk in the bottom of the relief and then position the speaker front to rear so that an equal amount of the enclosure extends beyond the boss on each end.

It would be best if you set this aside for overnight or for a few hours to cure. If you must press on right now, keep checking back that the speaker enclosure hasn't shifted as you work.

Figure 23 was taken after the trucks were wired and the wires secured per step 9. At this time you wouldn't have the Kapton

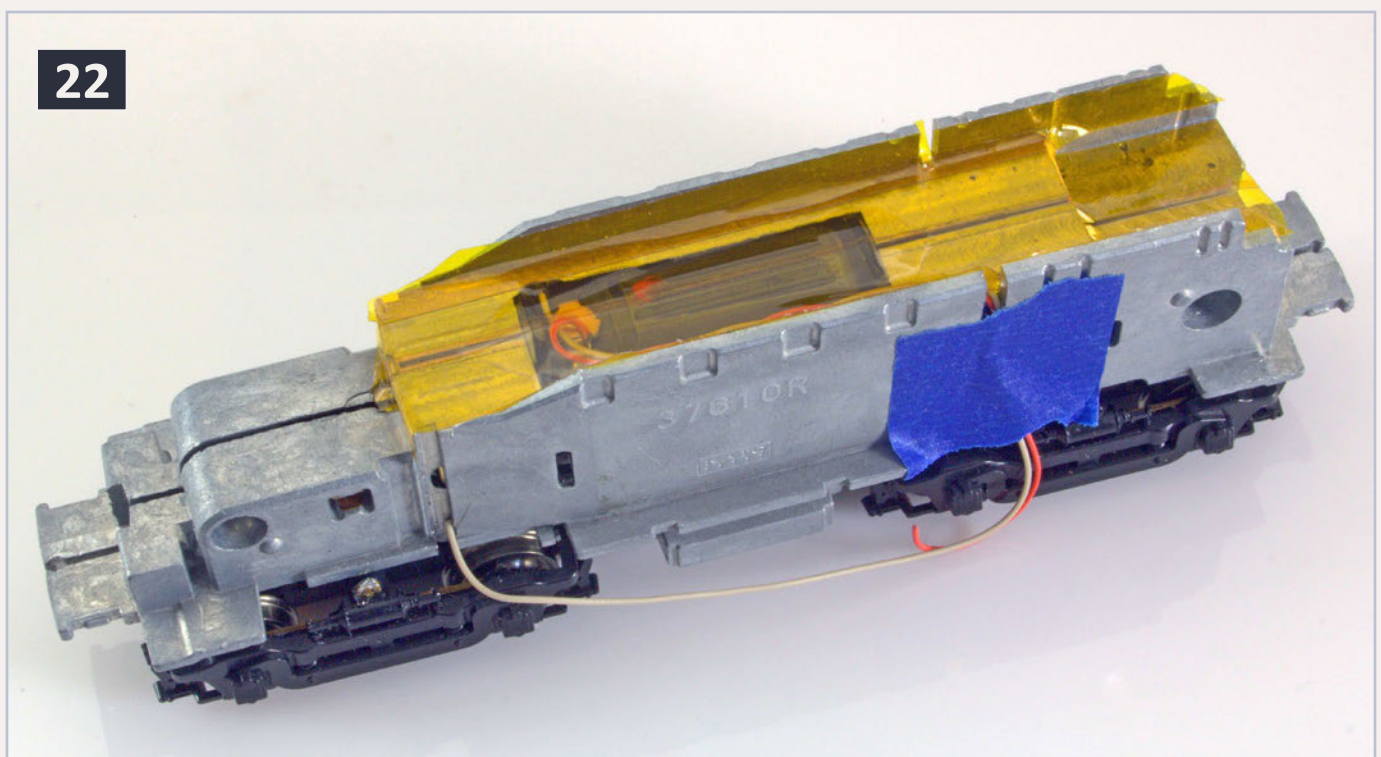

22: Decoder channel insulated with Kapton tape.



contents



index

23

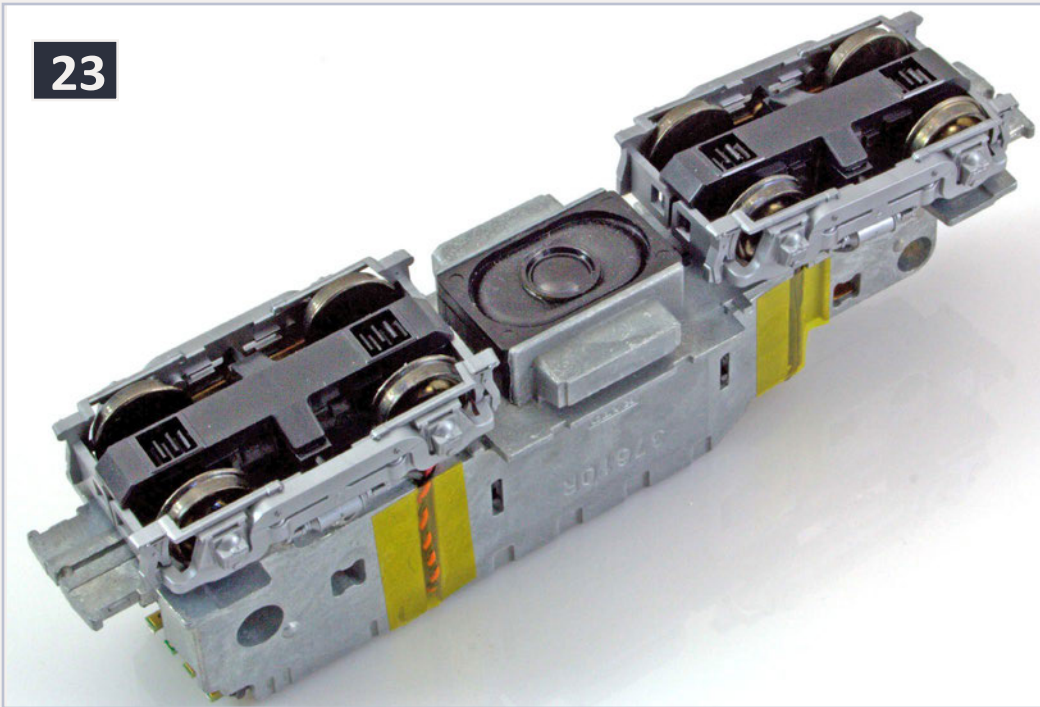

23:
Railmaster
DS1425-8
speaker
mounted
in the fuel
tank relief.

tape covering the wire troughs running up the sides of the loco or the trucks in place.

Position the speaker leads up the right front trough and hold them in place with a bit of blue tape. Hint: you don't need to hold the motor wires down the same trough now – the Kapton on top of the loco is holding the motor wires in place.

9.0 Wire trucks

I like really flexible wire to connect the trucks to the decoder. At Litchfield Station we sold a product that has 51 strands of very small wire to get up to 29 AWG. It had very flexible rubber insulation. We called it Wire-2951. When I first stocked it, it was available through Northwest Short Line. When they were transitioning owners, it went out of stock. I believed so strongly in it that I found an alternate supplier, even though I had to buy thousands of feet of it. Northwest Short Line has a similar, but possibly less flexible wire now. It is 44 strands, making up 28-gauge (part number 10010-9).

Soldering wire directly to the trucks helps in many ways. It isolates the frame from the rails. It also eliminates several

potentially troublesome contact locations: the sliding contact between the trucks and the copper strips and the non-sliding contact between the copper strips and the frame halves. This should improve your operational reliability.

9.1 Solder wires to trucks

Use a motor tool and a brass brush to clean off the contact point at the top of the truck. Quickly tin the point. Strip and tin some Wire-2951 and quickly solder it to the tinned contact point. You need to be quick with your soldering so as to not melt the plastic details on the truck side frame. Cut the wire about 2 inches above the frame. This is a bit long, but I don't want to be short and need to redo the solder joint on the trucks (24).

9.2 Secure truck wires to frame with 3/8" Kapton tape

Once you have all four truck pickups wired, apply 3/8-inch Kapton tape to hold the wires in their channels. When you are done with this step, your loco should look like figure 25.

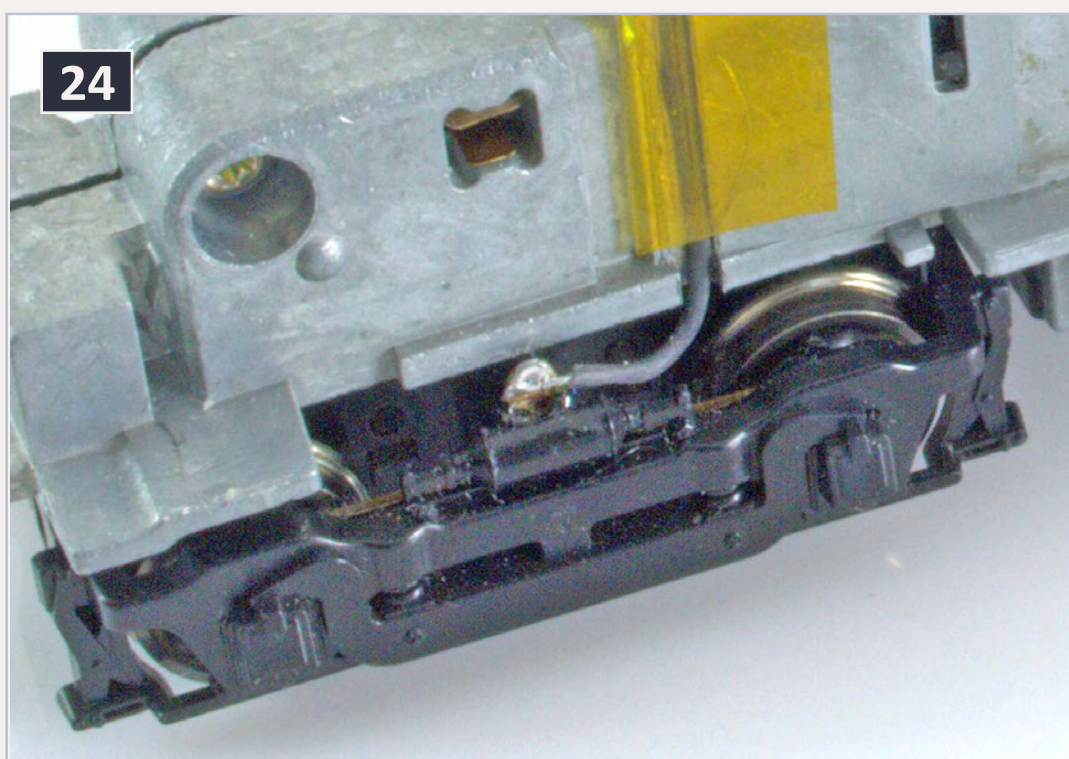

24: Close in photo of the wired truck after step 9.2 is done.



contents



index

25

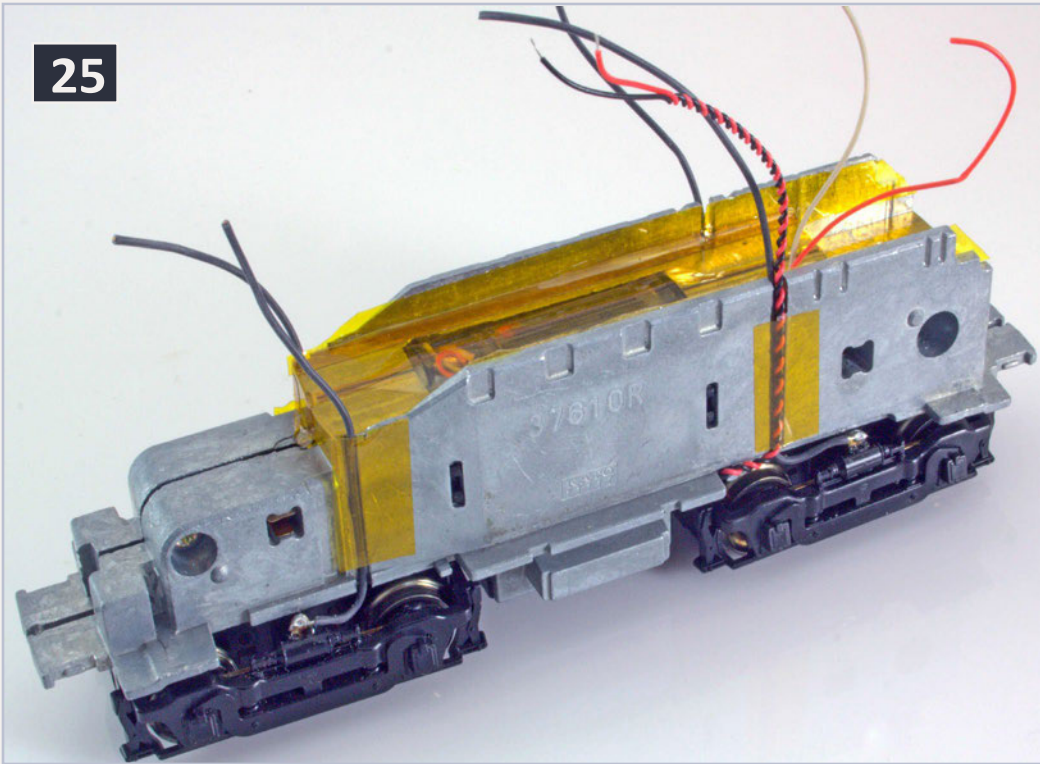

25: Top view of the trucks wired, after Kapton tape has been applied to hold the wires in place.

10.0 Install and wire decoder

Now, we get down to the fun part. You can see the locomotive return to running condition. Figure 26 shows the locomotive at the end of the work here in section 10.

10.1 Set decoder in position and secure

In the end, the decoder is not held in place by any mechanical method. The sides of the frame will keep it in line (that's why we put Kapton tape on them). The wires will hold it front to back.

This installation is designed for the SoundTraxx TSU-GN1000 decoder (part number 678-828050 with the EMD 567 sound file). The decoder needs to be installed with the FRONT lettering toward the back of the loco and the power supply capacitors in the well behind the headlight. Hold it temporarily in place with a bit of blue tape, as shown in figure 26.

10.2 Wire motor

Cut the orange and gray wires to length and solder them to the motor pads. If you observed polarity when removing the

motor, the orange wire will go to the M+ pad and the gray wire to the M-pad.

If you are at all unsure as to whether you got the motor polarity right, leave the wires long and just tack solder them into the motor pads. After you test the loco, you can cut them to length and dress them.

10.3 Wire speaker

Make sure the speaker wires are dressed such that they won't interfere with the swing of the front truck. I like to hook them around the boss that previously held the copper contact strip for the right side of the trucks. If the wires are a bit stubborn, I will even put a dab of caulk between the wires and the enclosure and clamp them in place to keep them out of the way of the wheels.

Solder the speaker wires to the speaker terminals on the decoder. The polarity makes no difference, since this is a single

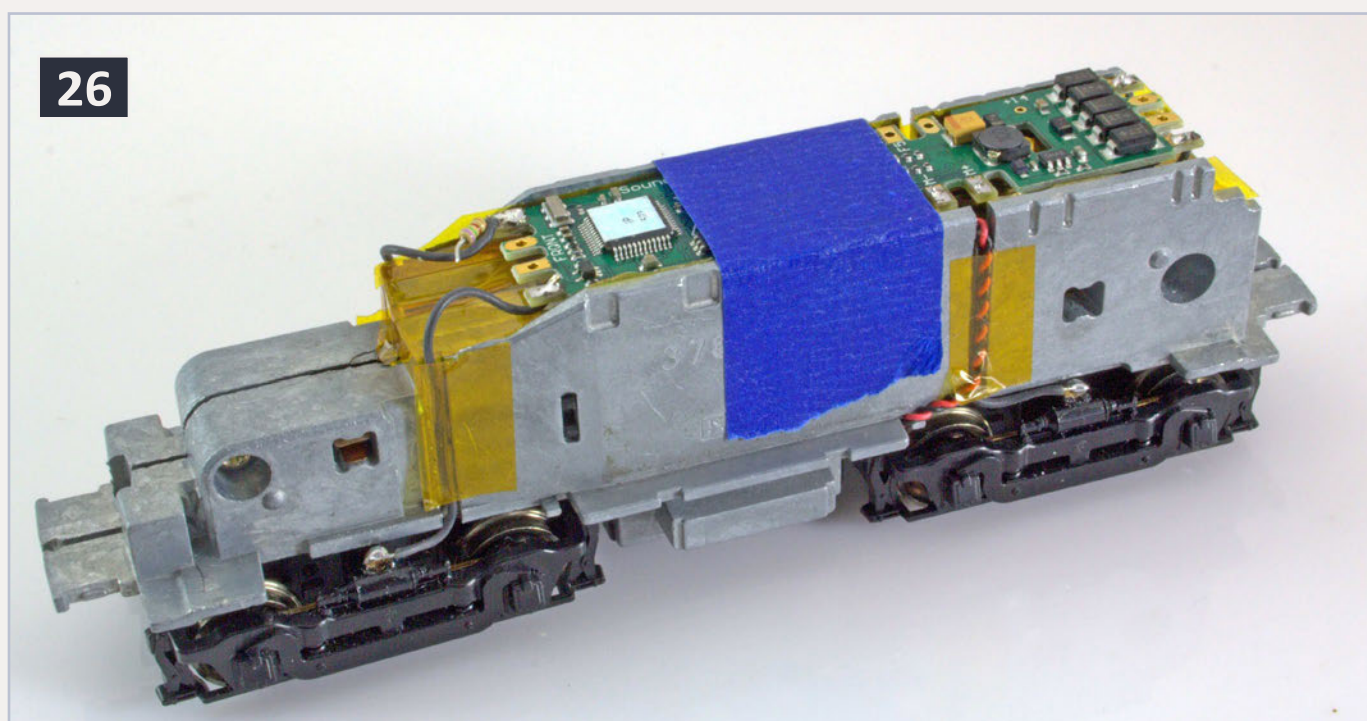

26: TSU-GN1000 decoder held temporarily in place with blue tape.



contents



index

speaker installation. However, I'm anal retentive enough that I wire red to the S+ terminal and black to the S- terminal.

10.4 Wire Trucks

Connect the Wire-2951 leads from the trucks to the terminals on the decoder. If you are going to use this loco on DC, you will want to observe proper polarity and wire the right hand truck wires to the left side terminals on the decoder. Since I don't plan DC operation, I just ran the wires to the nearest track pad, as seen in figure 26.

To facilitate the installation of the lights, wire one end of the remaining 750-ohm resistor to one of the track pads, along with the truck wire. On the end of the decoder labeled FRONT, you can choose either side. Figure 26 shows it connected to the left track pad.

Your loco should look like Figure 26 now. Time to remove the blue tape that is holding the decoder on.

11.0 Test

You should now have a functional loco, minus the lights. So, let's go and test our work.

Go to your programming track. Do not put the loco on track with full power applied until you verify your installation on the programming track. If you need a programming track booster (mrhmag.com/url/mrdccu-ptb) to read CVs with your system, make sure it is in place and functional.

Read the short address. It should be 3. Write a different short address and read it back. If you want a long address, write and verify it at this time. I like to do this in DecoderPro and create a file for the new loco at this time. Then future tweaks can be

made on the main, where you can hear and see the results of your changes.

If you are unable to read from the decoder, carefully check your wiring for any shorts. Use a buzzer to verify that there is no path from the motor leads to either frame half. Likewise, there should be no continuity between the trucks and the frame halves. Check the speaker, too. It should be totally isolated. Check for continuity between the wheels and the rail contacts on the decoder. Check for motor continuity between the M+ pad and the M–pad.

If you are able to read and write CVs on the programming track, then you can operate the loco to the main track and you should get sound and motion, but no lights, yet. Make sure the loco goes forward when the DCC system tells it to do so. If the loco runs backwards, reverse the M+ and M– leads at the decoder and retest.

12.0 Final Assembly

Let's get this guy back together. Finalize the motor wiring and lead dress, if necessary.

12.1 Rebuild Cab

To reassemble the cab, start by hooking the rear light board assembly over the tabs on the rear lens inside the cab roof. Then install the rear window set, snaking the yellow and blue wires through the troughs molded in it for the original contact strips. Slide the front window set into place. The side windows snap in place securing the front and rear windows and the gray LED housing. Some adjustment may be necessary to seat the front and rear windows so that the side window assembly will seat correctly and hold them all in place. Snap the cab floor



contents



index

into place, hooking its tabs into the holes in the side window assembly.

12.2 Wire the headlight

By now the Canopy Glue should have set up. Remove the blue tape and hold the LED down with a bit of 3/8-inch Kapton tape, as shown in figure 28.

Since we are wiring the headlight, The LED needs to connect to the end of the decoder that is marked FRONT, even though those contacts are in the rear of the loco. The long lead on the LED, the one that lit up when the + buzzer lead was connected to it, goes to the resistor you have hanging off the rear of the decoder. The short lead goes to the rectangular pad on the FRONT end of the decoder.

In figure 27, the wires are wrapped around the pad and the resistor, ready to be soldered. Solder the wires in place.

This is what is known as Half Wave Lighting. Instead of the positive voltage coming from the blue lead, it comes from one of the track pickups. They are the same voltage for this purpose, but the rail voltage is only turned on about half the time (see the DCC waveform in my December 2012 column - mrhmag.com/dec-2012-dcc-impulses). With LEDs this makes a very small difference in the total light output, but makes the wiring so much easier. You'll see why later. This technique is frequently used in brass steamers, where the front LED or light is connected to the right rail in the boiler and the decoder is located in the tender. This saves one wire running between the tender and the loco.

12.3 Wire rear LED

The oval shaped pads on this decoder have 1.5 volts on them, as this decoder was designed to replace the light board in the

Athearn Genesis locos (hence the GN in the model number). However, SoundTraxx provided a +14 (volt) terminal on the decoder. A LED and resistor combination (designed for 14 volts) can be connected between there and the function terminal.

Cut, strip and tin the wires from the cab assembly. Solder the blue wire to the +14 terminal and the yellow wire to the rectangular pad on the end of the decoder that is not marked FRONT (28).

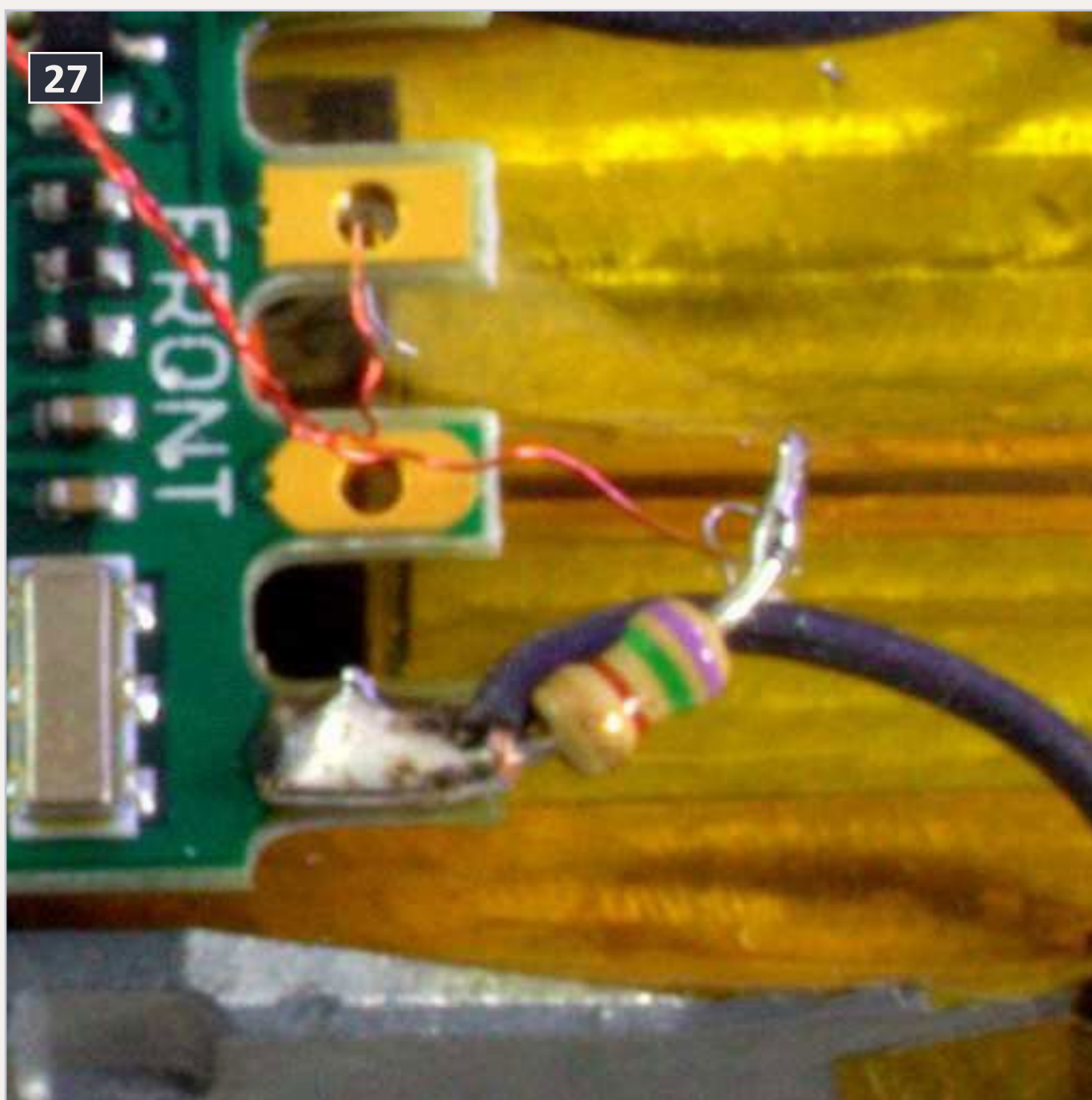

27: Headlight wiring in place.



contents



index

12.4 Slip shell over frame and test lights

Be very careful not to pinch wires, while you slip the shell over the top of the frame. Push it down a bit until the bottom of the shell just touches the nubs on the frame that will hold it in place. The shell is now keeping the frame halves together, not the clamping screws.

Running the loco on the main track, it should be totally functional. If a LED doesn't light, make sure that you have F0 selected and that the LEDs are wired correctly. In a pinch, reverse the leads to the non-functional LED and see if that fixes the problem.

Since it has not been programmed yet, the loco may run faster than you desire and have a really quick start.

13.0 Program

Program the loco to have the personality you wish. On my web site I have the DecoderPro file that I used for this loco. You may wish to copy it to your computer and use it as a starting point (mrdccu.com/install/hods/Kato-NW2-828050.htm). Rename the file to what your loco should be called. Go to the basic tab and input the address(es) you want. Use the programming track to Write All Sheets from this file. Once that is done, then programming on the main will work just fine to make final adjustments.

This file limits top speed to about 40 SMPH. It has a bit of momentum, but not too much, as this is a switcher. With a bit of practice, I can get the loco to coast into a coupler and just latch and then pull away. There are adjustments to the equalizer and reverb. A single chime horn is selected and sounds adjusted.

Locos differ and yours will probably have different motor responses. The file I have posted had the motor parameters adjusted for the specific loco, so that it just starts about speed step 2 or 3 (using 128 speed steps, as I recommend). If you want to tweak the starting response, that is covered on my web site (mrhmag.com/url/mrdccu-tsunami-slow).

14.0 Finish installation

Just a few more steps and you will be done.

14.1 Seat shell on frame

Go ahead and seat the shell firmly down onto the frame.

14.2 Fuel tank

We've got the speaker in the fuel tank, but it doesn't look pretty. Also, the speaker magnet will attract iron and steel

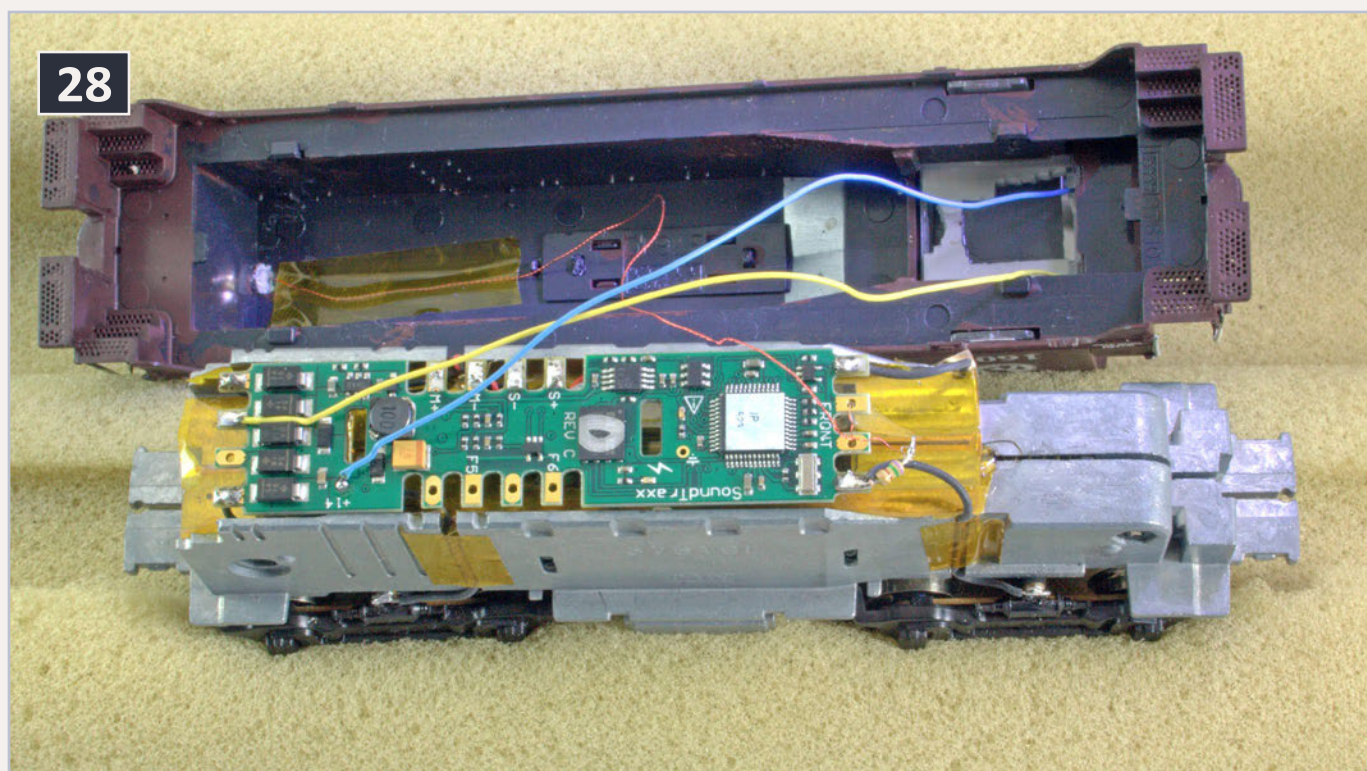

28: View inside loco with both LEDs wired to the decoder – note the slack so that the shell can lie next to the loco on the foam cradle.



contents



index

items from your roadbed. If they bounce around on the speaker cone, the sound gets really bad.

Now it is time for the black panty hose. I'm sure that those of you who looked at the parts list ahead of time have been scratching your head on that one.

Remember that the speaker enclosure was a bit longer than the boss molded into the frame to hold the fuel tank? Okay, here's how we deal with that one.

Cut the sides off the plastic fuel tank detail part. Check the sides to fit against the metal bosses on the frames. Make sure you have the correct detail part on the correct side of the loco. They are not the same. The left hand side has a piece that extends fairly far forward. The right side piece doesn't extend as far back.

Cut a piece of black panty hose to cover the speaker from front to rear and to extend side-to-side about half way down the air tanks. Carefully (I use a toothpick) apply a bit of caulk all the way around the speaker. Don't get any on the cone, as it will dampen the sound. Slightly stretch the panty hose material and press it down onto the bead of caulk you created. Apply a fairly large bead of caulk on the air tank area and press the sides in place and down against the frame. Use a one-handed bar clamp (29) to hold them in place for a few hours until the caulk sets up – I recommend overnight.

Now you have some grille cloth on top of your speaker to help control the debris pickup. It won't prevent the pick up, but will help keep the debris away from the speaker cone. I recommend checking for accumulation from time to time.

While the caulk is setting up, we can do some of the final work with the loco in the foam cradle. Just be careful not to bump the clamp.

14.3 Final lubrication

Remember that we only put light (10) weight Nano-Oil on the gears? Well, it is time to provide longer-term lubrication with heavier weight Nano-Oil. With the loco still in the cradle, put one drop of the 85-weight Nano-Oil on each of the four exposed gears on the bottom of the loco. When you run the loco, this will get distributed throughout the entire gear train, all the way up to the worm gear.

Dirt and corrosion are enemies of electrical contact, making for irregular sound and performance. Daylight Sales provides the electrical equivalent of Nano-Oil, called Never Stall. It lubricates and cleans electrical contacts and inhibits corrosion. Put a drop of Never Stall on each wheel bearing where it contacts the copper pickup plate.

14.4 Reinstall couplers

Now you will understand why I wanted to take the couplers out in one assembly for each end of the loco. You can just snake



29: Finish the fuel tank with speaker grille cloth and modified plastic parts. [... On to next page of text →](#)



contents



index

Sound decoder installation video

By MRH DCC Columnist,
Bruce Petrarca

90 minutes, step-by-step

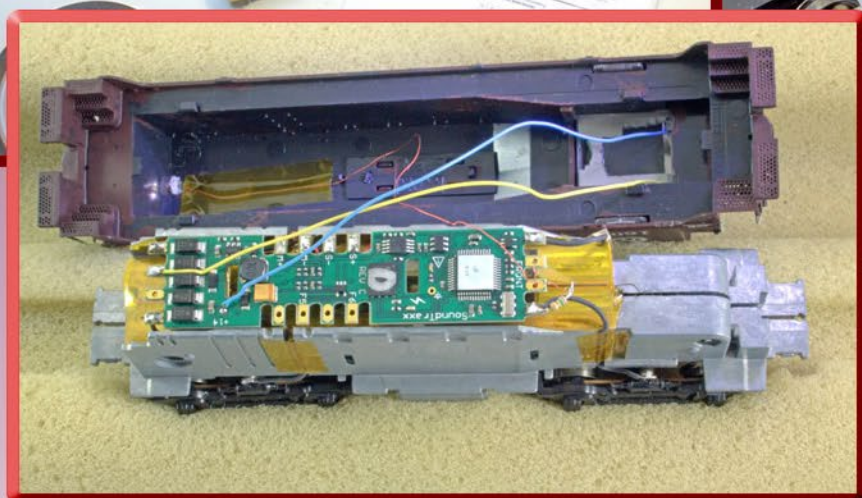
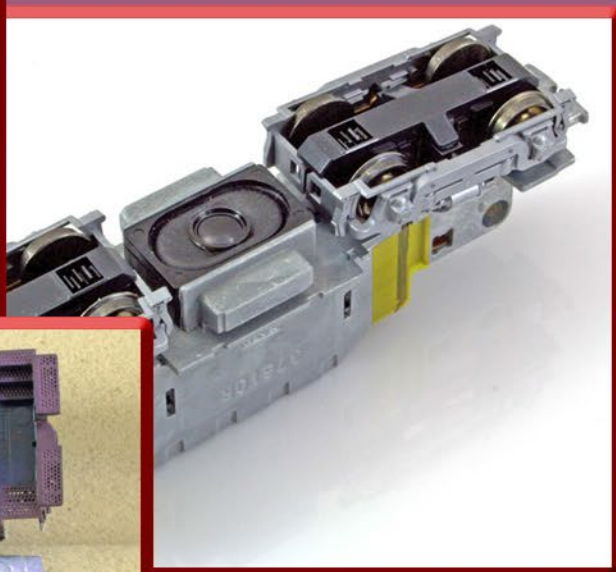

**Available for immediate download
January 21st!**

\$4.99 STD
\$5.99 HD

Learn more...



[← back to previous page of text ...](#)

the assembly back in, somewhat as you did to get it out. Once in place, just press it down with a screwdriver.

If you disassembled the couplers, you will need to reassemble them onto the frame working around the shell details. That is more difficult, in my opinion.

Now you have a NW2 switcher with sound, you lucky person!

Non-sound decoder

This same design could be used with a non-sound decoder. You wouldn't have to split the fuel tank or install the speaker. If you used an insulated decoder, you wouldn't have to apply Kapton tape to the frame. However, the installation would be very much the same. But once you have the frame machined, why not put a Tsunami in it and have sound? The cost differential is just a couple of R-T-R boxcars.

I hope you got something out of this column. There are a bunch of tricks and tools that won't fit into this column that I cover in the feature-length video.

This will probably provoke a bunch of comments on the MRH blog site. Click on the Reader Feedback link below and join the discussion. I hope you are inspired enough to rate the article Awesome on your way by!

I wish you green boards until next month! Don't forget to look at the discussion of the long awaited NCE PowerCab upgrade (version 1.65) in this month's "From Mr. DCC's Workbench" sidebar. 

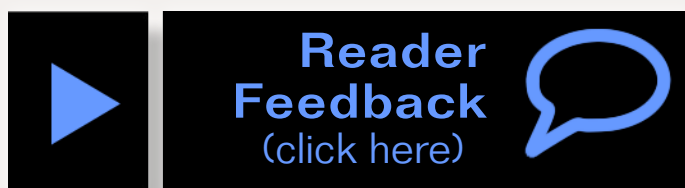

contents



index



30: Lubricate the entire gear train with one drop of 85-weight Nano-Oil on each exposed gear.

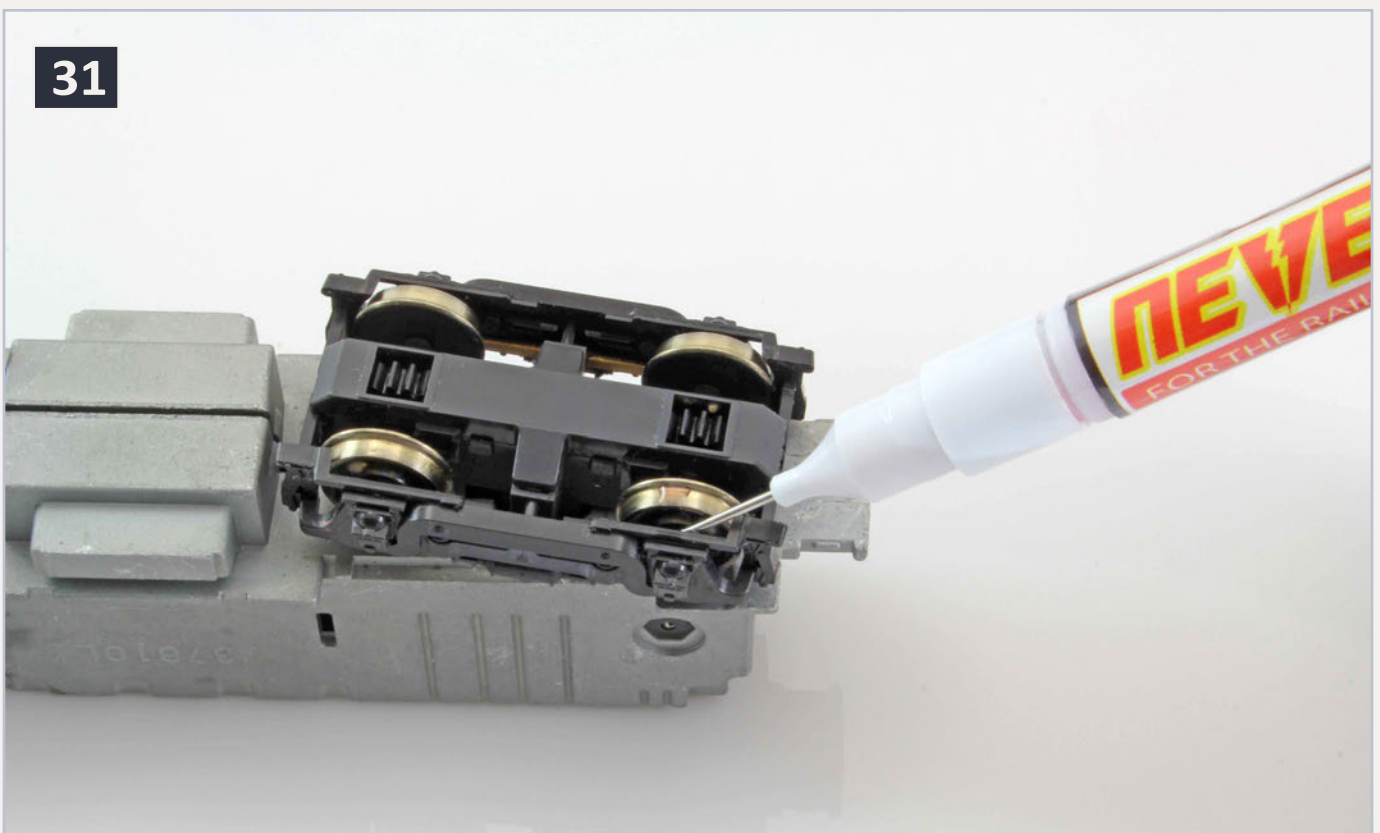

31: Apply one drop of Never Stall to each wheel bearing.

Parts, Supplies and Tools

The frame will need to be milled out to provide room for the decoder and speaker, as well as relief to get the wires from the trucks and speaker to the decoder. I had George at TVW Miniatures (tvwminiatures.com/contact.html) do the ones that I used for this column. The raw frames are no longer available from Kato's parts department, so I didn't want to screw one up experimenting with it.

Parts

All of the parts (except the panty hose) and most of the supplies for this installation are available from Model Railroad Hobbyist sponsor Litchfield Station (litchfieldstation.com).

- Decoder – SoundTraxx TSU-GN1000 with EMD 567 sound file part 678-828050
- Speaker – Railmaster Hobbies DS1425-8
- Rear LED – Richmond Controls 3mm Golden White LED
- Front LED – Richmond Controls SMD Golden White LED with 6 inch leads
- Resistors – two each 750 ohm 1/8 or 1/4-watt
- Cab floor replacement, if needed – Styrene about 1 inch by 1 inch, 0.020 inch thick
- Truck wires – Super flexible 29 AWG rubber insulated wire (Wire-2951)
- Motor and rear light wires – 30 AWG wire from TCS in colors:
 - Orange
 - Gray
 - Yellow
 - Blue
- Black panty hose – see text – don't just steal your wife's



contents



index

Supplies

- Kapton tape (if you can only have one size, I recommend 3/8-inch wide)
 - 3/8 inch wide
 - 1/4-inch wide
- Blue painters tape
- Styrene cement – I use MEK or Faller Expert
- Gray Krylon primer spray paint
- Clear acrylic bathtub caulk – I use Polyseamseal
- Formula 560 Canopy Glue
- Denatured alcohol or Ethyl rubbing alcohol
- Never Stall – electrical lubricant and corrosion inhibitor
- Nano-Oil – a MRH sponsor
 - 10 weight
 - 85 wieght

Tools

In addition to normal modeling hand and soldering tools, I recommend:

- A foam cradle
- Storage box for parts – with cover
- Small one-handed bar clamp
- Ultrasonic cleaner.

[... On to next page of text →](#)

Advertisement



A well
juiced
frog is a
happy
frog

Click here to keep your
trains rolling with our
Frog Juicers...

TamValleyDepot.com



Email

From Train Set To Club

NCE Covers ALL Your DCC Needs



NEW

DCC Twin

Includes power supply - Use Optional Cabs
- Perfect for Train Sets -

UPDATED PowerCab UPDATED
Includes power supply
- Great way to start DCC on your railroad -
Optional Cabs available

SB5 Smart Booster
5 Amps - Six Optional Cabs
Includes Power Supply

NEW

PH Pro
- 5 Amps of power for Z, N, HO, S Scales -
Optional Cabs

PH Pro R
- 5 Amps of power for Z, N, HO, S Scales -
Optional Cabs
Wireless Operation



PH10
10 Amps of power for
O and G Scale layouts

PH10 R
PH10 with Wireless Operation

585.265.0230
9am-4pm EST.
www.ncedcc.com

NCE

The Power of DCC

Call or Email
for FREE Brochure
support@ncecorporation.com



Look for these **NEW NCE PRODUCTS** at your local dealer



PB5 - New version 5 Amp Booster
Includes power supply

UTP-CAT5 Panel
Use common CAT5 cable
to hook up your Cab Bus



NCE Corporation builds products in Upstate New York - Right here in the U.S.A
We build our products to the NMRA Standards and Recommended Practices where applicable



From Mr. DCC's Workbench

Release of new software for the NCE PowerCab – Version 1.65

In November 2012, NCE announced the long-awaited release of its upgrade software for the PowerCab. Version 1.65 replaces 1.28C, which has stood for quite some time. NCE is supplying the upgrade free of charge to folks who bought their PowerCab in the last 20 months. If yours is older, \$25 will fix you up.

This software upgrade is a real boost to folks who use the PowerCab as the basis for a small to medium layout, as I do. If you are mostly using your PowerCab on the workbench and as a Pro Cab on a larger NCE system, there is very little in this upgrade for you. So you may not want to upgrade if you have an older unit and need to pay for the software. Here are NCE's claims for the new version:

- 1) Support for up to 6 recalls – two recalls remains the default
- 2) Support for 3 external throttles, using addresses 3, 4 and 5
- 3) Support for 3 AIU, USB or Mini-Panels in addition to the extra throttles
- 4) New thumbwheel control of CV programming values. For example, when programming on the main, you can select the CV value for the volume on your sound decoder and ramp it up or down with the knob or the speed buttons. I like this one a lot.
- 5) Easy operation of the last thrown turnout – press the SELECT ACCY twice in a row and the last used accessory will toggle to the opposite position.
- 6) Programmable ProCab mode timeout so multiple PowerCabs can be used together more easily.

7) Support for Analog Fast Clocks – I don't know what this means and haven't gotten a response from NCE yet. They are swamped getting the upgrade out to all the users.

8) New, improved USB/computer commands

I got the upgrade for my PowerCab and installation is a breeze.

First, note any of the settings that you have in your unit, per the instructions. These settings are stored in the chip you are going to replace, so they won't be there once you change to the new chip.

The hardest part is taking all nine screws out of the back of the PowerCab. Once you have it open, a small screwdriver pry under the ROM chip on the main board will remove the old one. I recommend a slight bend of the new leads, as shown in the accompanying NCE documentation, before you insert the new chip. A quick visual check that all 28 legs are in the correct socket and you are ready to put the cab back together and enjoy your new functions. ■

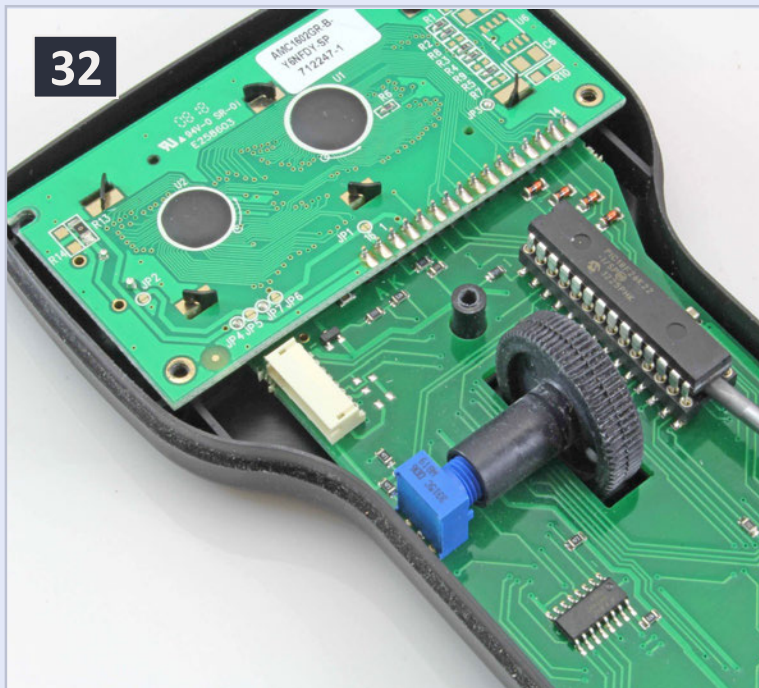

32: Removing the PowerCab chip to upgrade software.

Advertisement



THE "MOLE"

Saves Money ... AND
Saves Space ... AND
Saves all that CRAWLING
Under the Layout





Southern Digital

Specializing in DCC Since 1992



**20% Discount
on most Items!**

WWW.sodigi.com
(770) 929-1888

(Photo from our N-Scale layout)



DigiFrame Kit



Complete Train Control



**Click here for
more info ...**



contents



index



The Amherst Railway Society Railroad Hobby Show

Our 2013 Show will be

January 26 & 27, 2013

Save the dates!



About The Show

Every year late in January or early in February, the Amherst Railway Society holds its Railroad Hobby Show at the Eastern States Exposition Fairgrounds (The home of The Big E) in West Springfield Massachusetts. More than 25,000 railfans and public attended the Show each of the past three years.

The event features real life railroads and scale model railroads, historical societies, travel agencies, art shows, flea market dealers, importers, manufacturers and photographers. You have to see it to believe it!

[Click to
learn
more ...](#)





Mainline south, continued

Doing roadbed, backdrop, and lighting



Getting Real column: Adventures in prototype modeling
by Nick Muff

Modeling the Kansas City Terminal Railway and the Kansas City Southern ...

My last column documented the creation of the new benchwork for the mainline addition to my Kansas City Southern Railroad. I have reviewed some comments on the previous article about the relative inflexibility of the modular plywood benchwork, that I created, including some scenic contours. Those comments are certainly correct.

There is a spectrum of philosophy about this. It varies from John Allen who planned meticulously in advance, installing wiring for signals which would not be installed until 10 years later! On the other end of the spectrum is George Sellios, who does not do elaborate planning in advance, but the layout takes shape as it is constructed.

Obviously I tend toward the John Allen end of the scale. That said, there is very little in my current benchwork that could not be changed by removing screws and using a jigsaw and hammer!



1: Helix, lower level.

The Helix

The next step on my layout was to complete the four levels of the helix. The lowest level is the return loop at the far end of trackwork, behind Shreveport Union Station. The second level up shows where the benchwork, to the right, connects to the lowest level of the helix, leading to the left, with a piece of one-quarter inch Masonite. Four-and-one-half turns above this reaches track level on the upper deck, at Siloam Springs, Arkansas (1).

The helix starts its descent at Siloam Springs in the back distance curving to the left and around into the foreground. Fabricated plywood support arches stabilize the plywood benchwork in the center of the helix (2).

The helix then curves around to the right and ducks beneath the plywood deck at Siloam Springs (3).



contents



index



2: Helix upper level.

Figure 4 shows the helix as viewed from the platform track area of Shreveport Union Station. The Union Station, and backdrop, will hide the helix. The platform tracks extend through the station and the center of the helix enabling the station to handle longer trains.

Supports for the helix were adapted where the tracks from the return loop enter and exit. Half-inch plywood, 1" PVC pipe, and threaded rod were used to create this custom support (5).

Fitting the bridges

Once the helix was completed, I spent some time planning for and fitting the various bridges into the plywood sub-roadbed. A Micro-Engineering double track through girder bridge was fitted in place at Grandview, Missouri (6).

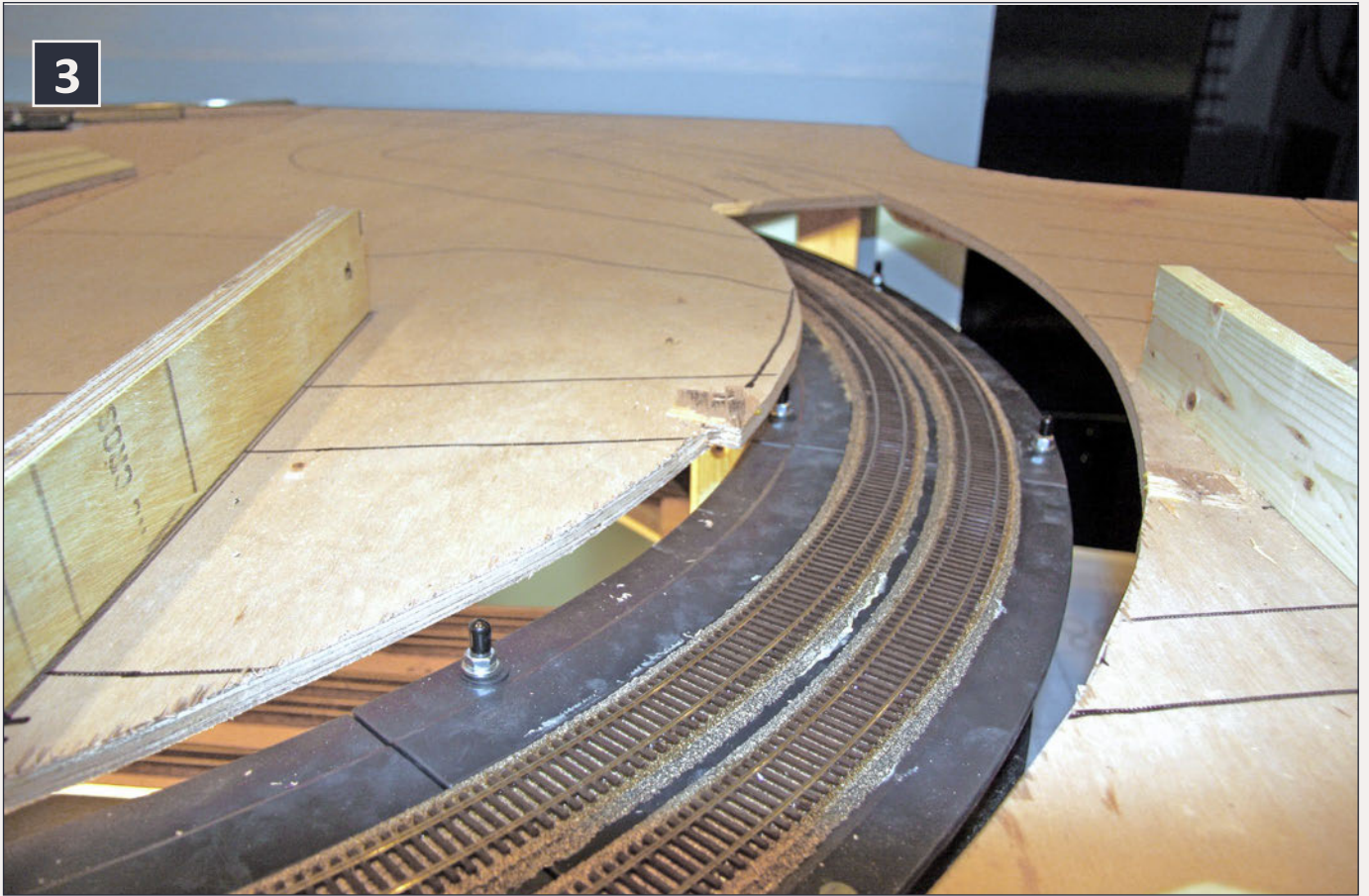

3: Helix dives beneath the upper deck.

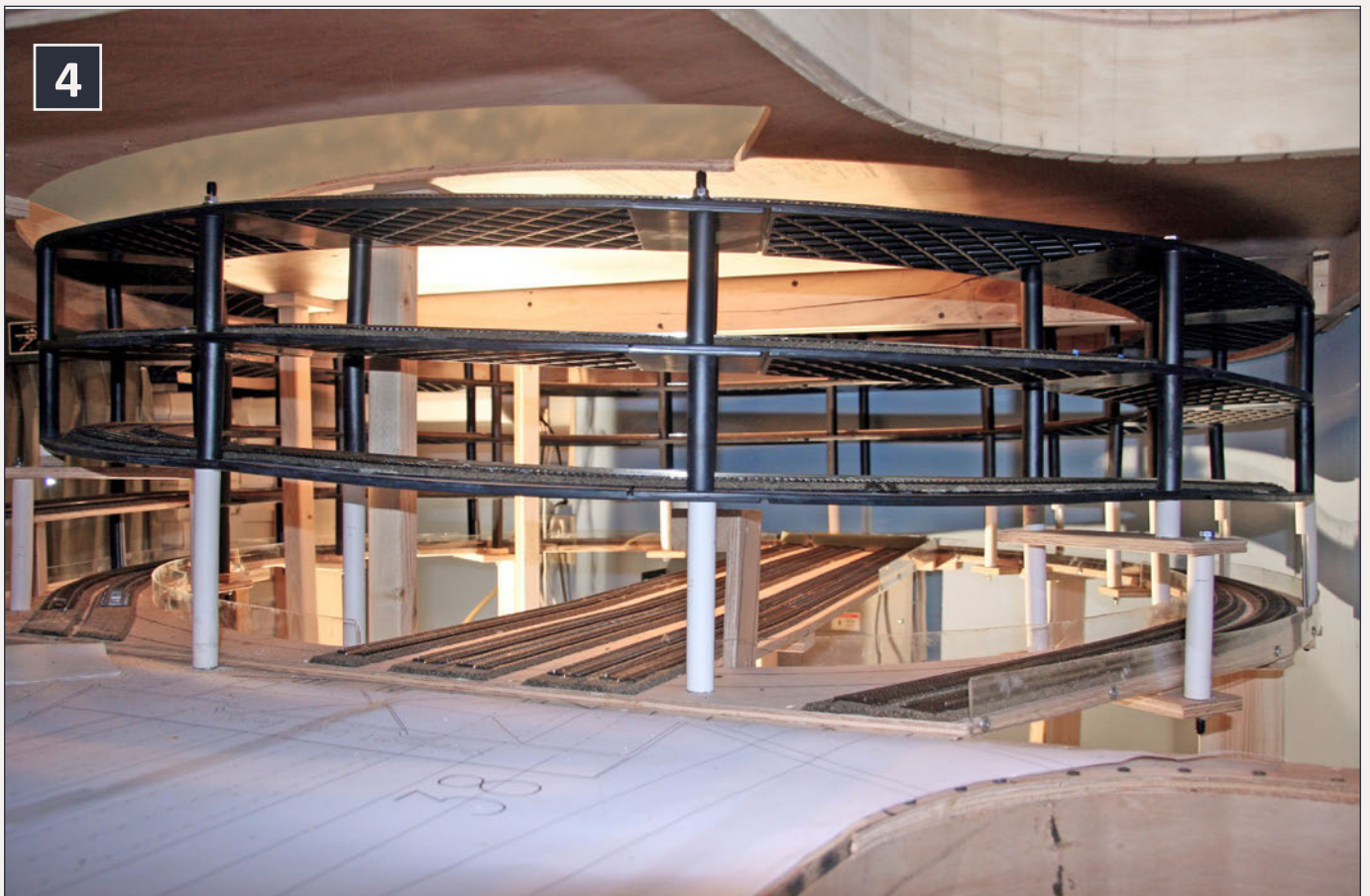

4: The helix at Shreveport Union Station.



contents



index



5: Custom helix support over return loop.

A Central Valley through truss bridge was placed over Spavinaw Creek, north of Siloam Springs. The model bridge was constructed for a different application. If you look carefully, you'll see that the photograph of the actual bridge shows two short through truss spans. The Central Valley bridge will be cut and adapted to match this configuration (7).

Figure 8 is a closer view of the Grandview bridge. The prototype featured a great Southern Belle sign on the bridge. One of the reasons for modeling the bridge here in the first place is to provide a location for that sign! It is an excellent way of establishing era and locale.

The upper bridge over Spavinaw Creek will be created using five Micro-Engineering deck girder sections (9).

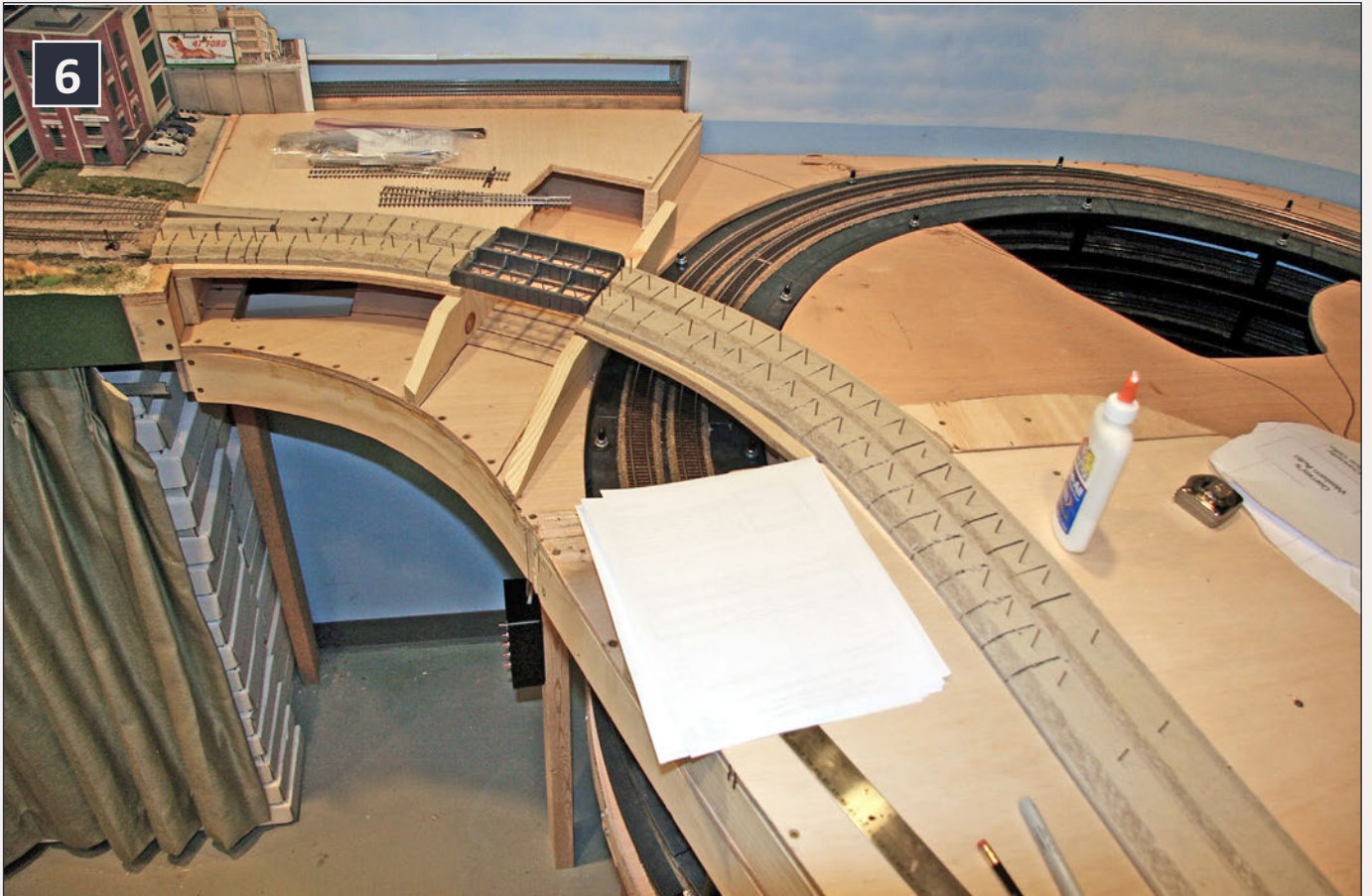

6: Trackwork, Grandview, Missouri.



7: Spavinaw Creek.



contents



index

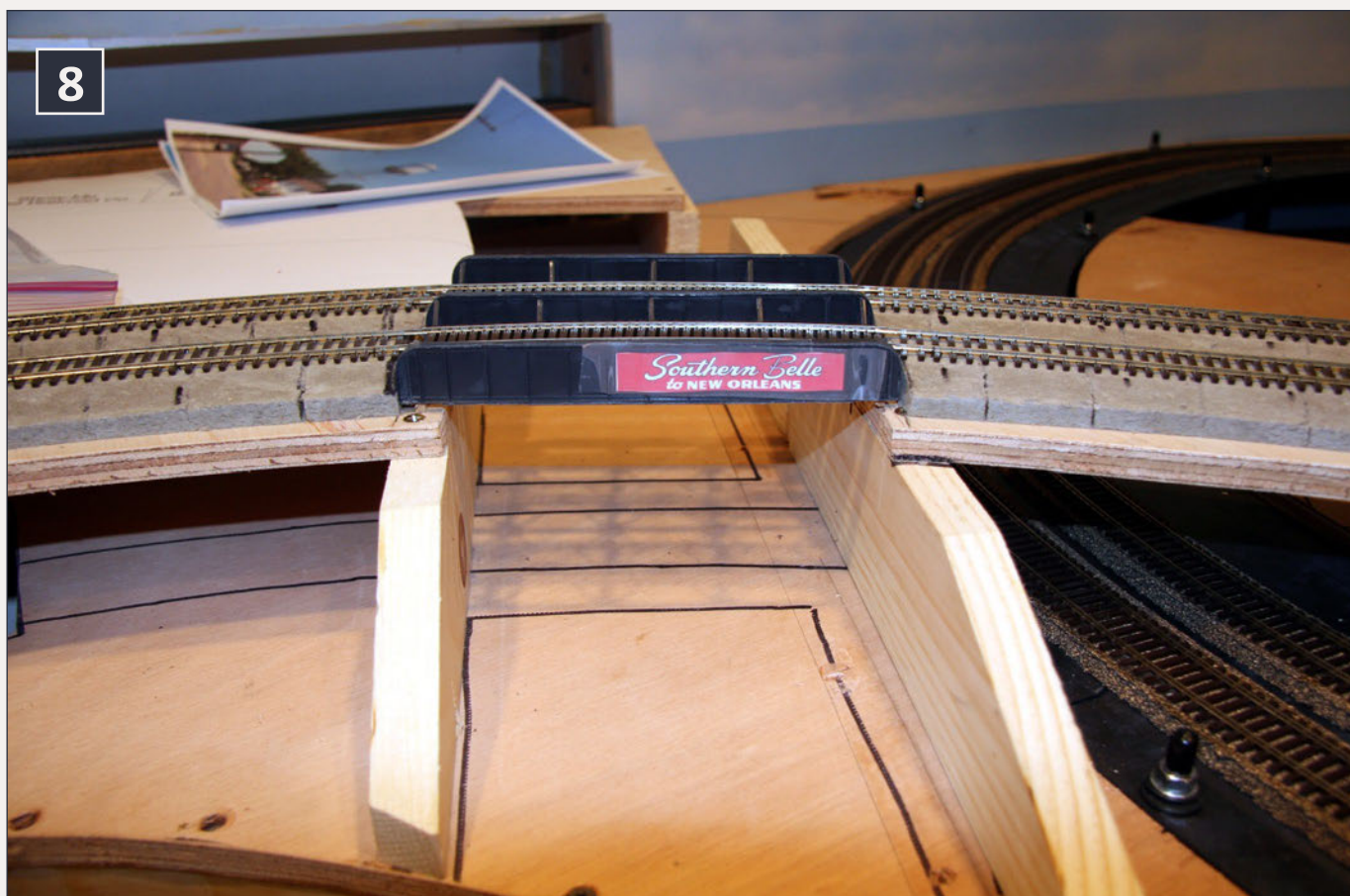

8: KCS bridge at Grandview, Missouri.

Cutting and laying the roadbed

Having established the basic configuration for the major bridges, the next step was to create and lay the roadbed. Having had good success with this technique in a previous layout I chose to use Celotex (also called sound board, or Homasote, a similar product). It is easy to work with and has excellent sound deadening qualities. The cost per sheet is about \$15. Roadbed for this section of the layout consumed two 4' x 8' sheets.

Orv Dunn published an excellent article in "Model Railroader" of May and June of 1967, "From Floor to Rail" (45 years ago, my how time flies! That's the year I married my wife). His sub-roadbed was created using the spline technique. On top of this he glued roadbed created from Celotex/Homasote using the

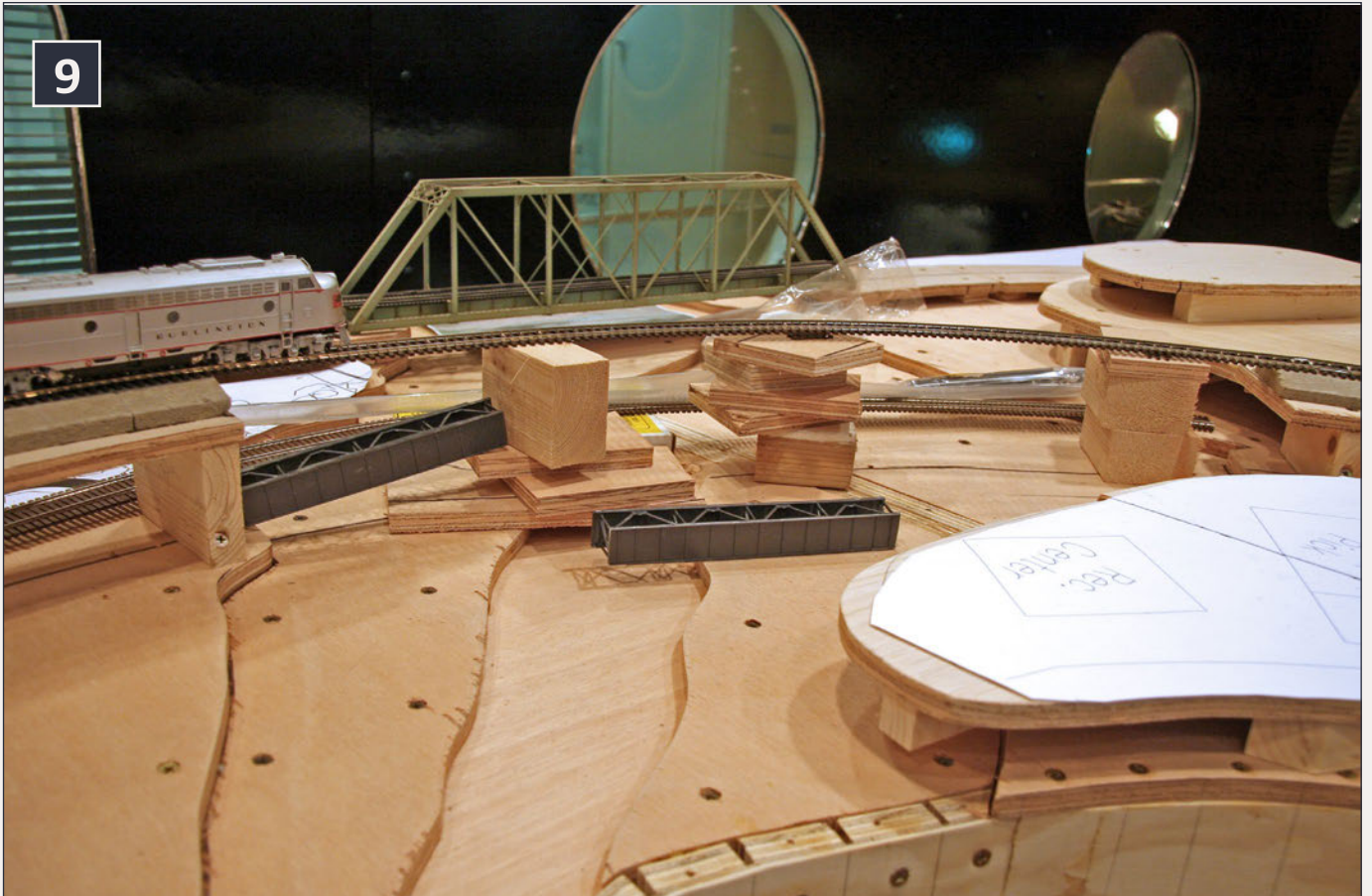

9: The high bridge above Spavinaw Creek.



10: Celotex roadbed cross section.



contents



index

11



11: Jig for cutting roadbed.

technique described below. Figure 10 shows the completed cross section of the Celotex roadbed. Diagrams A and B show how the profile was created.

The basic measurements for HO scale are shown in Diagram A. The dimensions for other scales are included in the original article. Diagram B shows how a length of 2 x 4 was used to create a jig to cut the ballast slopes. This jig covers the large portion of blade exposed in making these angle cuts (see diagrams A-B).

The 2 x 4 jig is fastened to the saw fence with screws (11). A second piece of 2 x 4 was clamped to the saw table to hold the length of Celotex against the jig and blade. Also a strip of wood was screwed to the top of the jig to hold the piece down on the

A

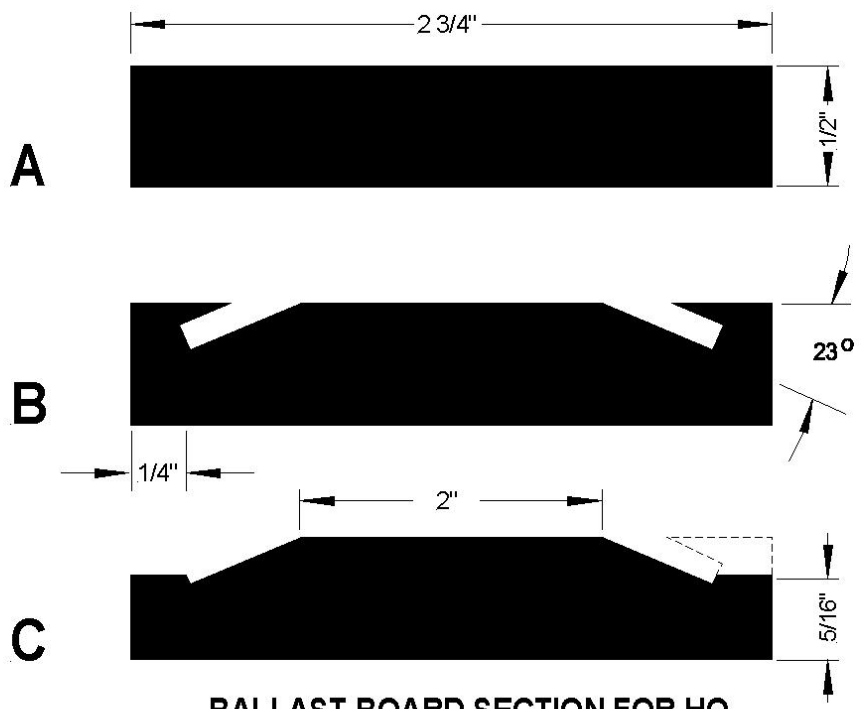

BALLAST BOARD SECTION FOR HO
(Using 1/2" Homasote or Celotex)

A: Roadbed cutting steps.

B

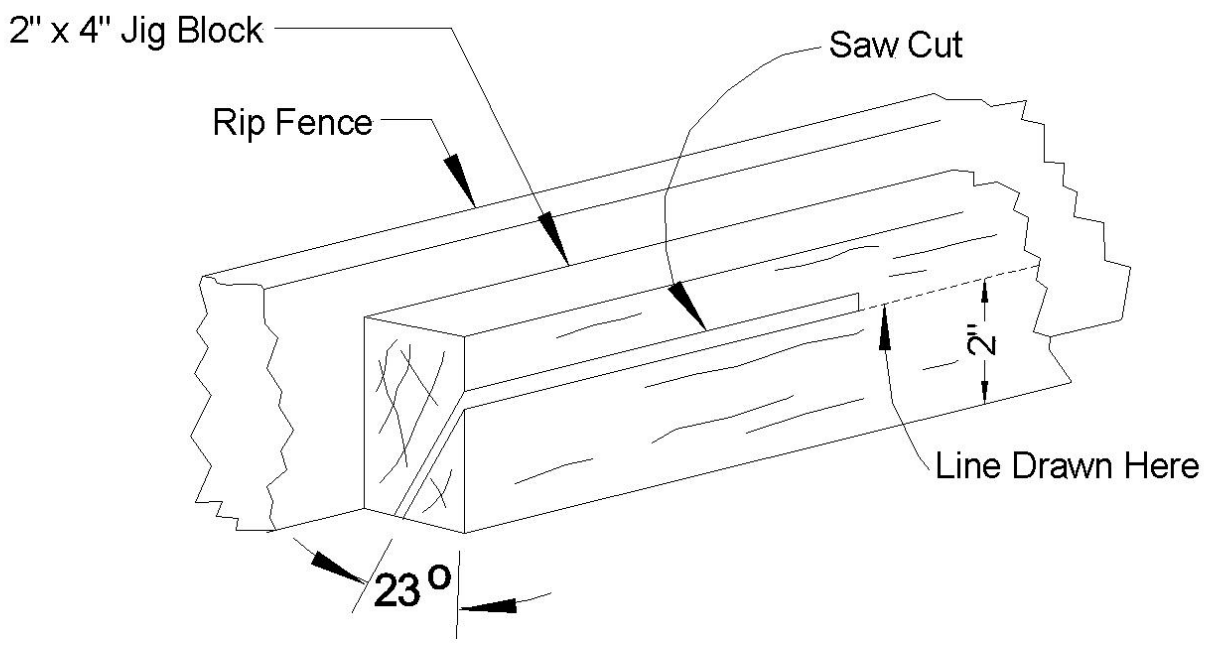

B: Cutting the 2" x 4" jig.

table. This keeps the work in accurate position and provides protection for the operator (12).

A completed length of finished roadbed is shown, on the saw table to the right of cutting jig, in figure 13. To lay curved sections, slots are cut about $\frac{3}{4}$ of the way through the roadbed to allow it to bend. The spacing for the slots is roughly the radius of the curve divided by 12. For a 30" radius $R/12 = 30/12 = 2.5$ " spacing between the slots. Lay the slots on the inside of the curve so that the slots tend to close as the roadbed is bent. A word of caution, cutting the Celotex generates a lot of fine dust! Work outside if you can. I call it clean dust, because it blows down and vacuums up readily. Save half a shopping bag full of the dust; it will be useful later!

For switches, a wedge-shaped section of Celotex is cut to match the number of the switch. For example, the wedge



12: Note the small amount of exposed blade.



13: Hold own pieces in place.

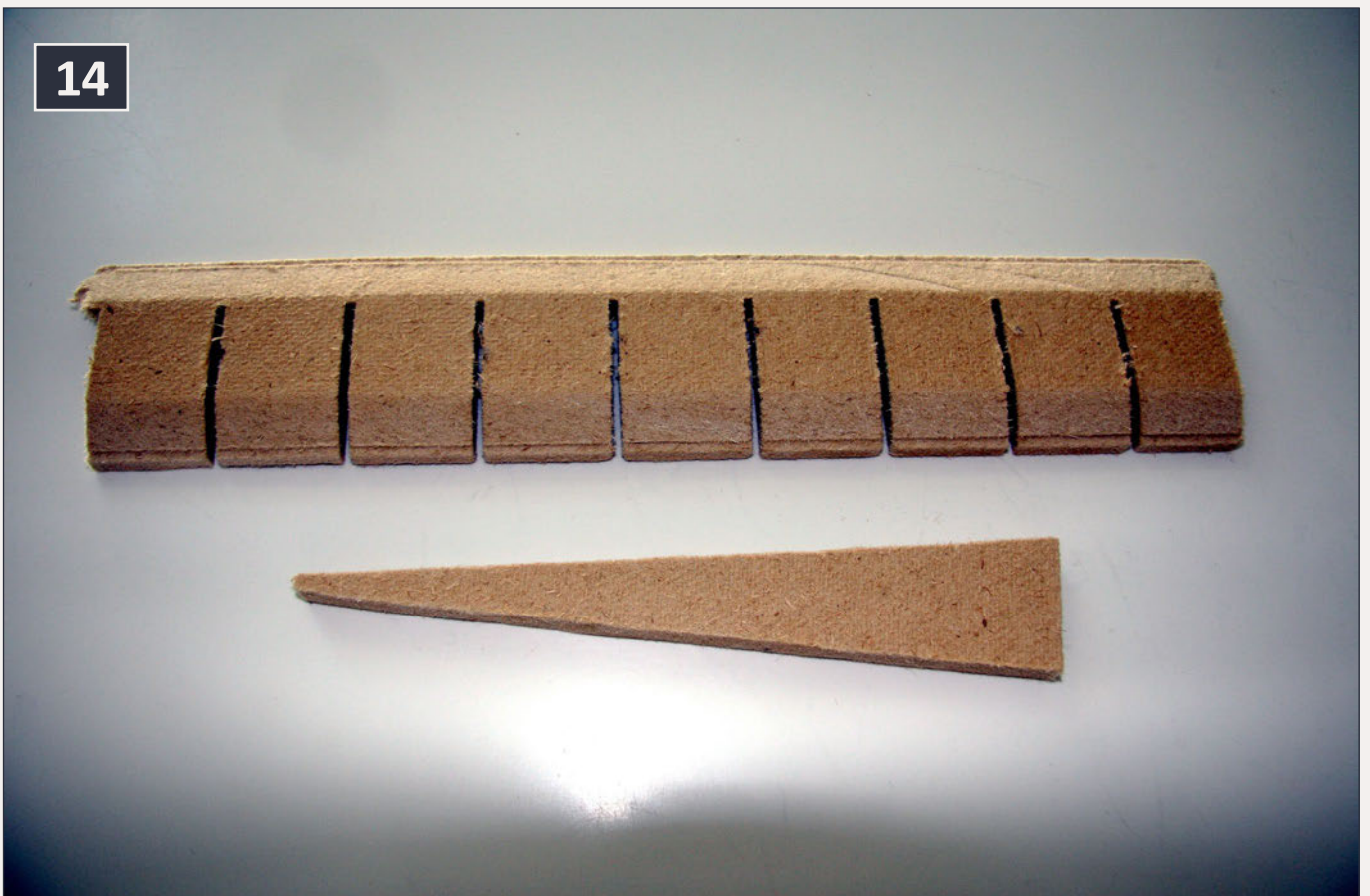

14: Roadbed cut for curving and switch insert.



contents



index

for a Number 6 turnout is 6 inches long and 1 inch wide (14).

To lay the roadbed, I use yellow carpenter's glue and 5d finishing nails. Lay glue along the centerline of the track and then use the finishing nails to hold the roadbed in place until the glue dries. The nails are left protruding, as they will be removed later. If the nails were driven home and left in place, this would defeat the sound-deadening qualities of the Celotex (15).

At the location of a single crossover, the sloped edges of the ballast were trimmed away, and a solid strip of Celotex without sloped edges was inserted (16).

When removing the finishing nails, use a piece of scrap 1/8" Masonite to protect the roadbed you just glued down (17).



15: Laying the roadbed.



16: Special switch work.



17: Removing the nails.



contents



index

Then use a sanding block with medium-grit sandpaper to remove rough edges and ensure that the top of the roadbed is smooth and flat for laying track (18).

Now it's time to use some of that fuzzy dust! Grab a handful and rub it firmly across the top of the roadbed into cracks, to fill the slots in the curved sections. Rub in a circular motion. Then lightly sand again and vacuum up the excess. Filling the gaps will save a lot of ballast when the time comes (19). In figure 20, the turnouts have been temporarily placed on the crossover roadbed. The squared ends of the center insert were then rounded and sloped with a hobby knife.

To lay the roadbed under a switch, a length of roadbed is split and the correct size wedge inserted (21). For the section of the layout which features a sugar mill, and narrow-gauge



18: Sand the roadbed top smooth.

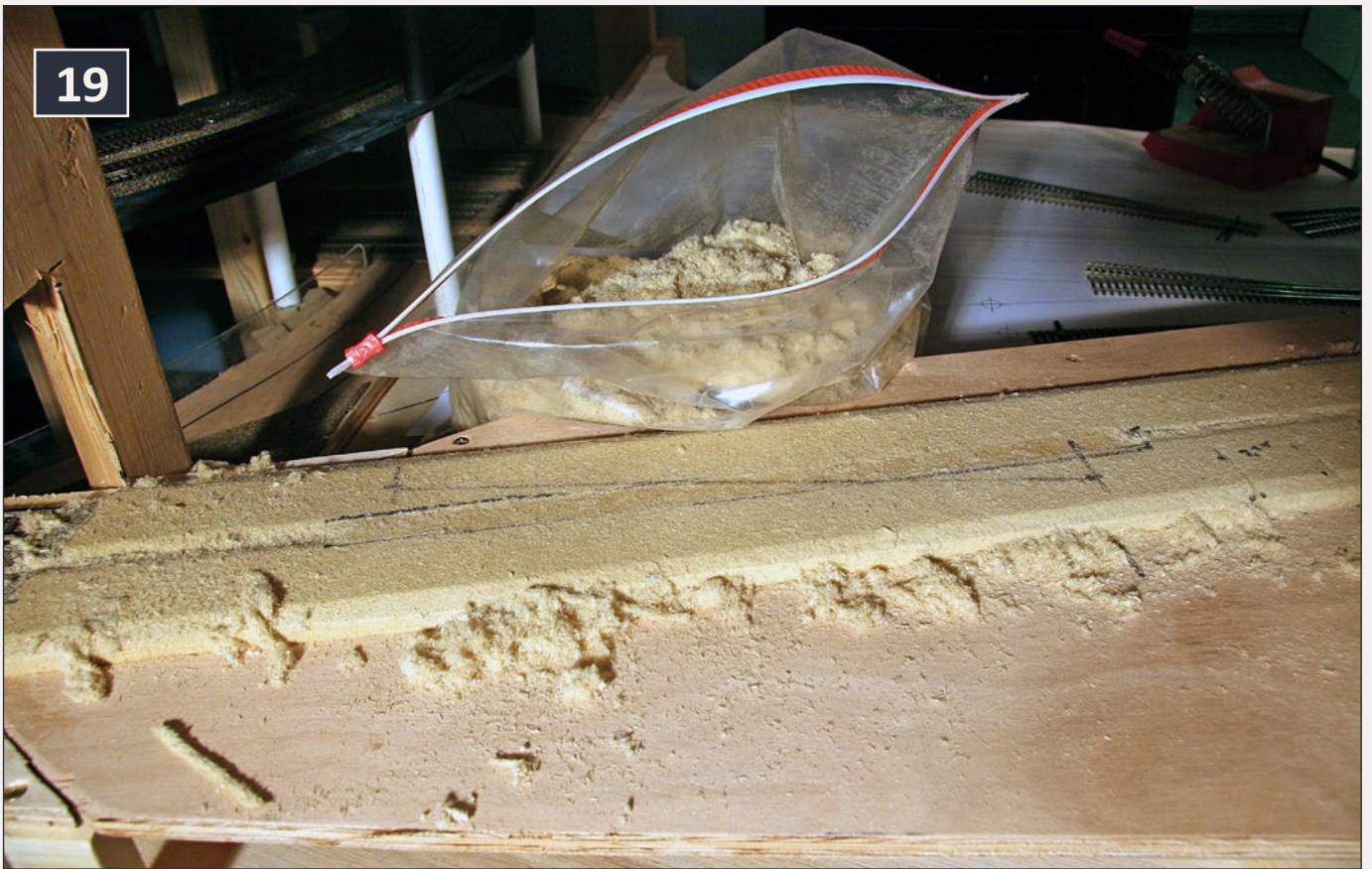

19

19: Fill the gaps with Celotex sawdust.

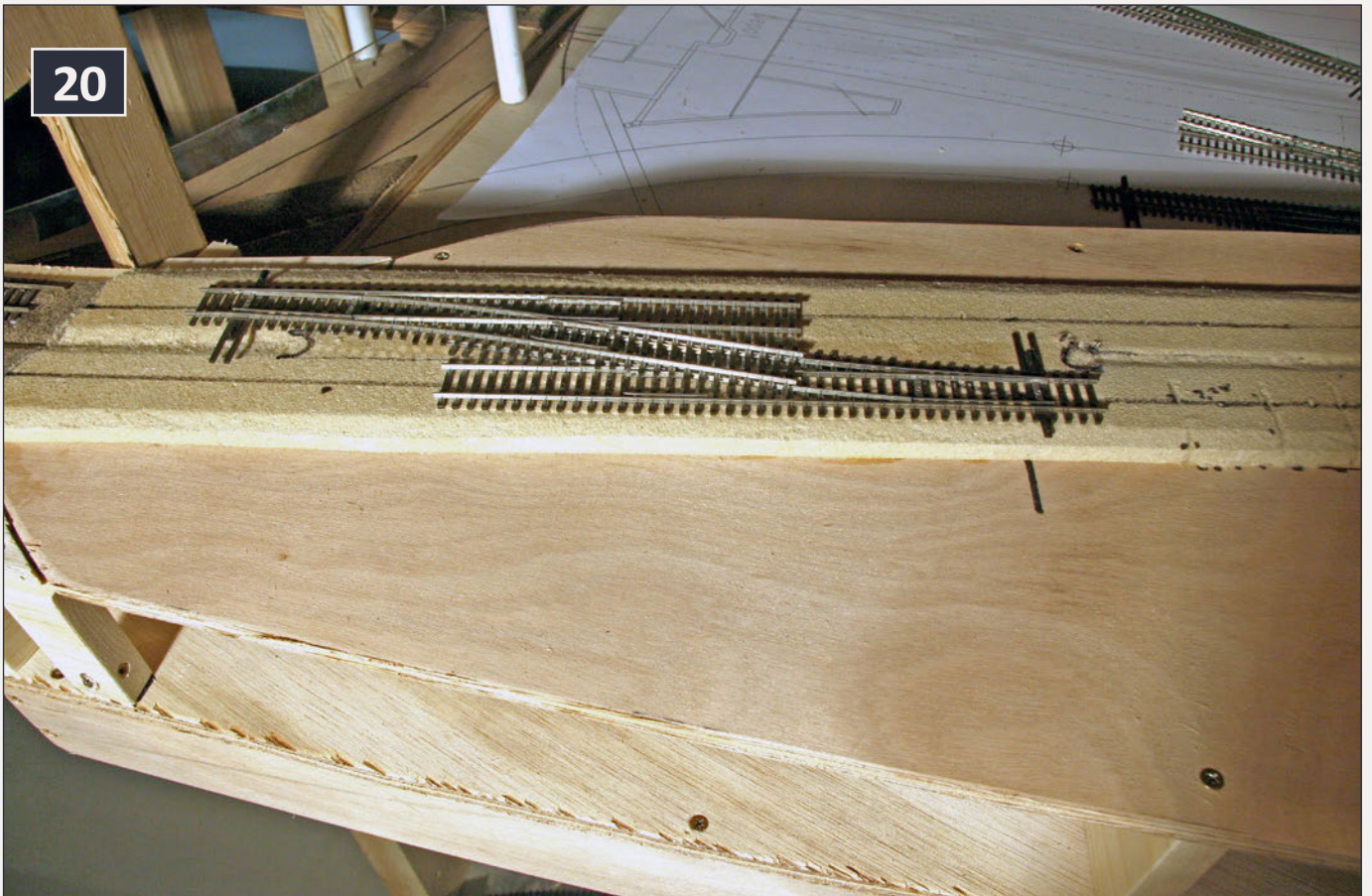

20

20: Turnouts laid temporarily in place.



contents



index

sugarcane railway, I just cut sections of Celotex to match the track plan. The edges were not sloped for this trackage which is basically laid in the dirt (22).

Where the downgrade meets the plywood deck, a tapered foam section from Woodland Scenic's Incline 2% Starter set was used to make the last ½" transition (23). For an area of complex track work, such as the north throat to the Deramus Yard, I started with a paper pattern (24).

The outer edges of this section were created by splitting a length of sloped roadbed in half. The center section was cut from a plain piece of Celotex. The ballast grooves between the track are cut away using a hobby knife (25).

The lower end of the layout required multiple pieces and a lot of cutting and fitted to match the complex track work in the

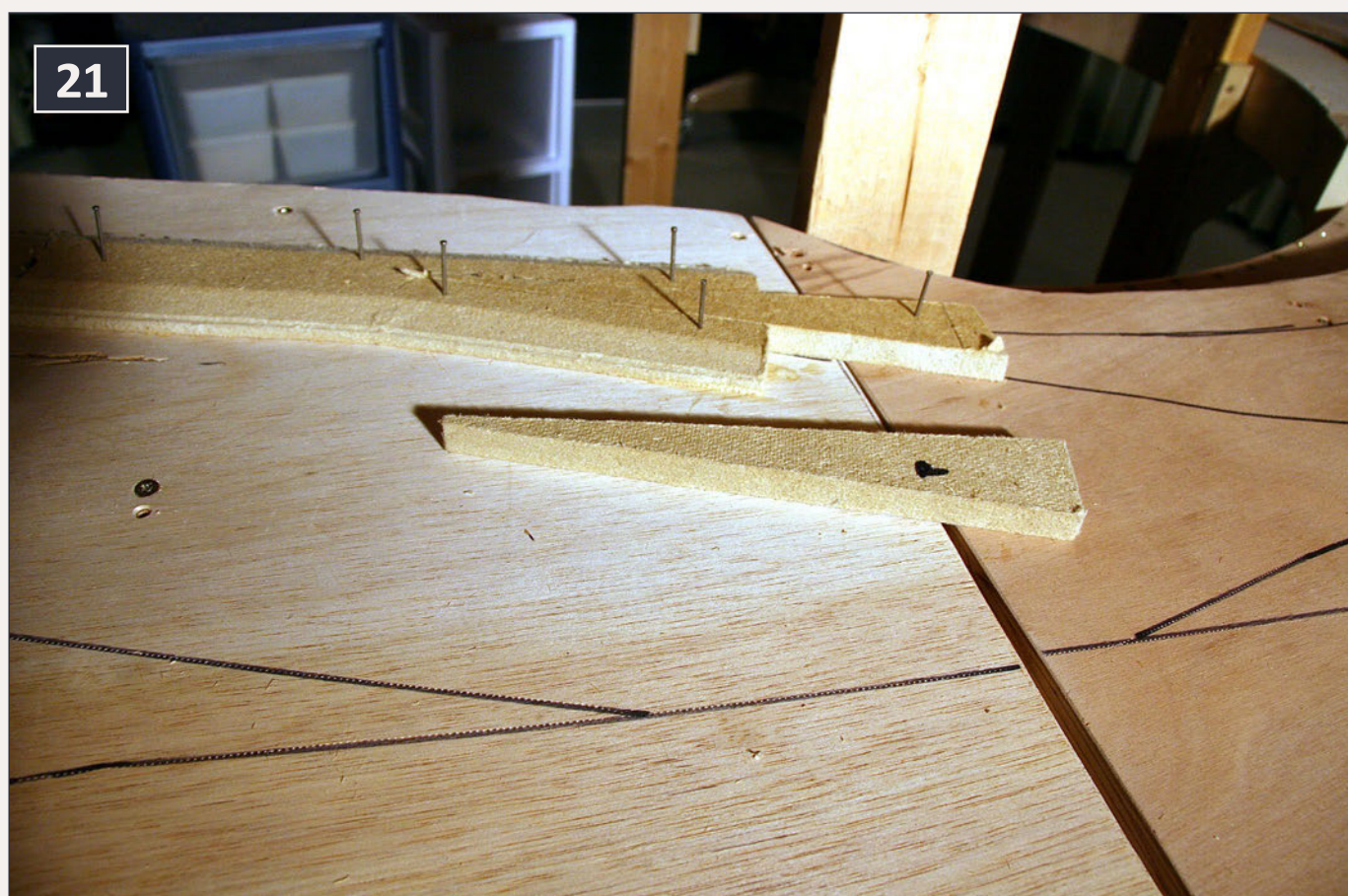

21: Laying roadbed for a turnout.

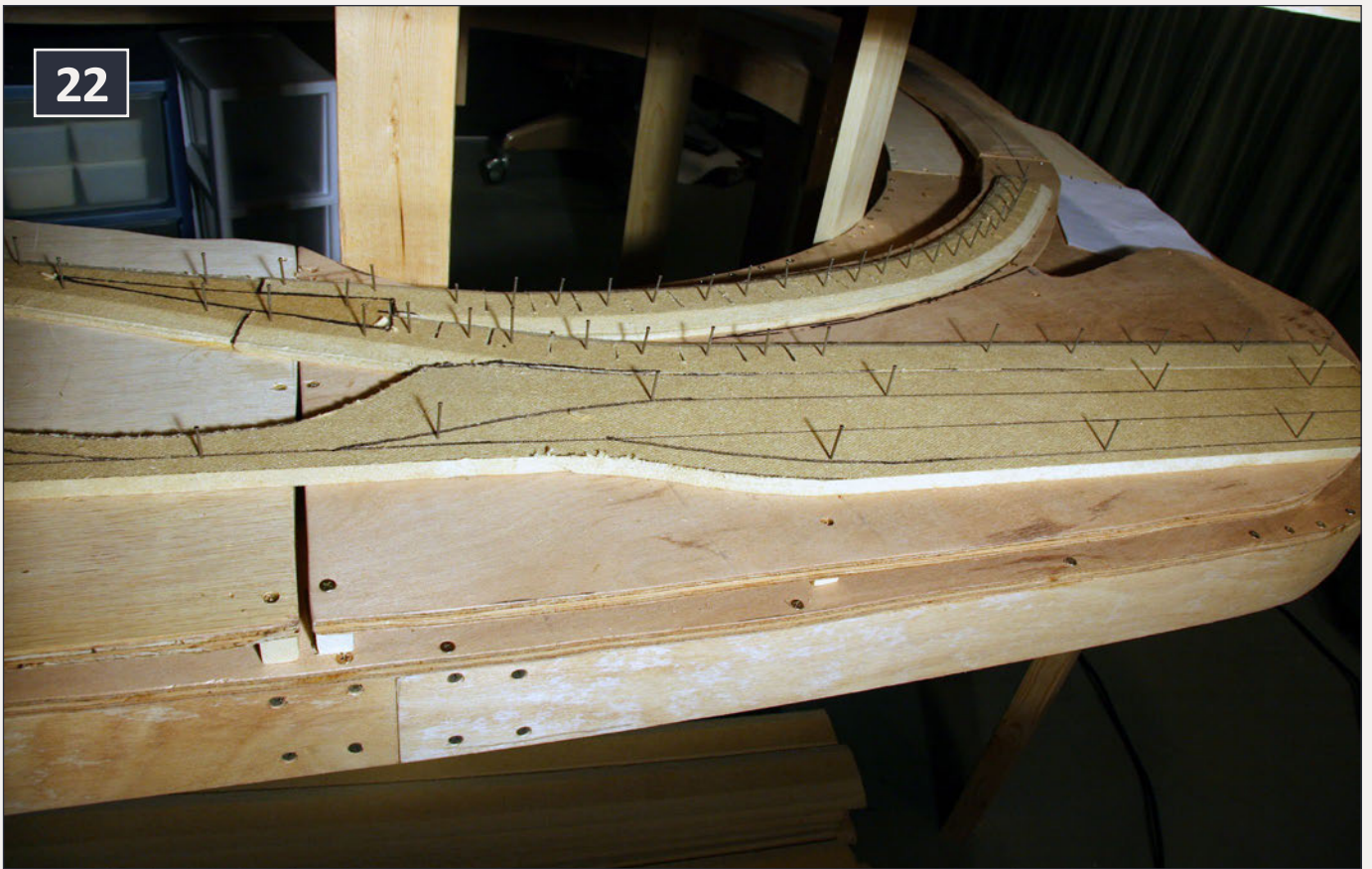

22: A single piece of Celotex is used under the sugar mill.

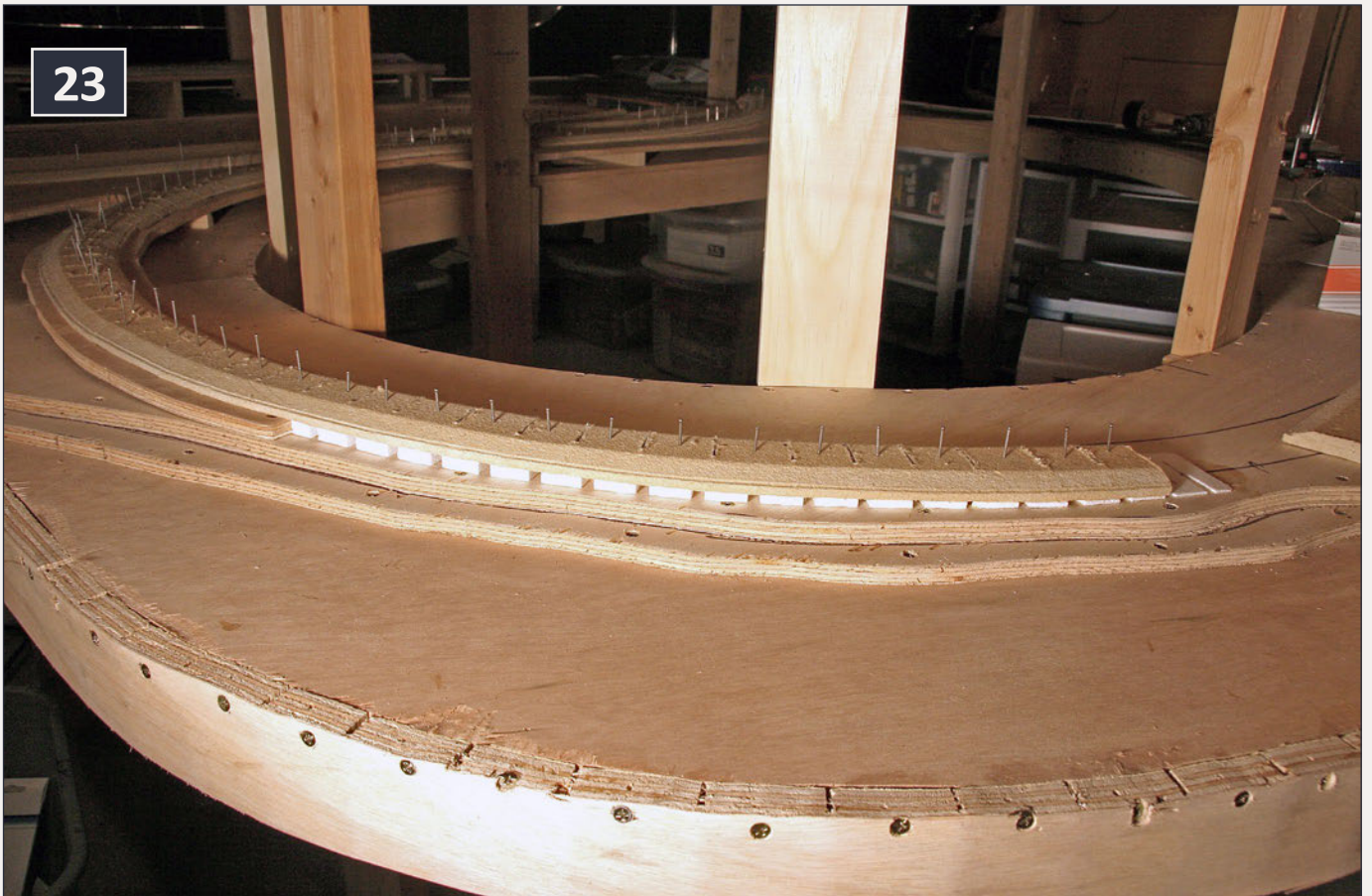

23: Woodland Scenics foam transition piece.



contents



index

area of Shreveport Union Station. It looks complicated but it goes down well; just take it one piece at a time (26).

Backdrop Panels

With the roadbed completely laid, it was time to create the backdrop panels. I use 1/8 inch tempered Masonite. I cut the pieces and temporarily fastened them in place so that they could be removed and taken outside for painting and the application of clouds. I used small blocks of wood at the bottom, occasionally at the top and behind the seams, to hold the pieces in place. This means I will have to hide the seams in the pre-painted pieces once they are installed. This can be done with chimneys, tall trees, buildings etc.

An alternative would be to fasten the backdrop pieces in place permanently, apply putty and sand the seams. This would



24: Paper pattern for complex roadbed section.

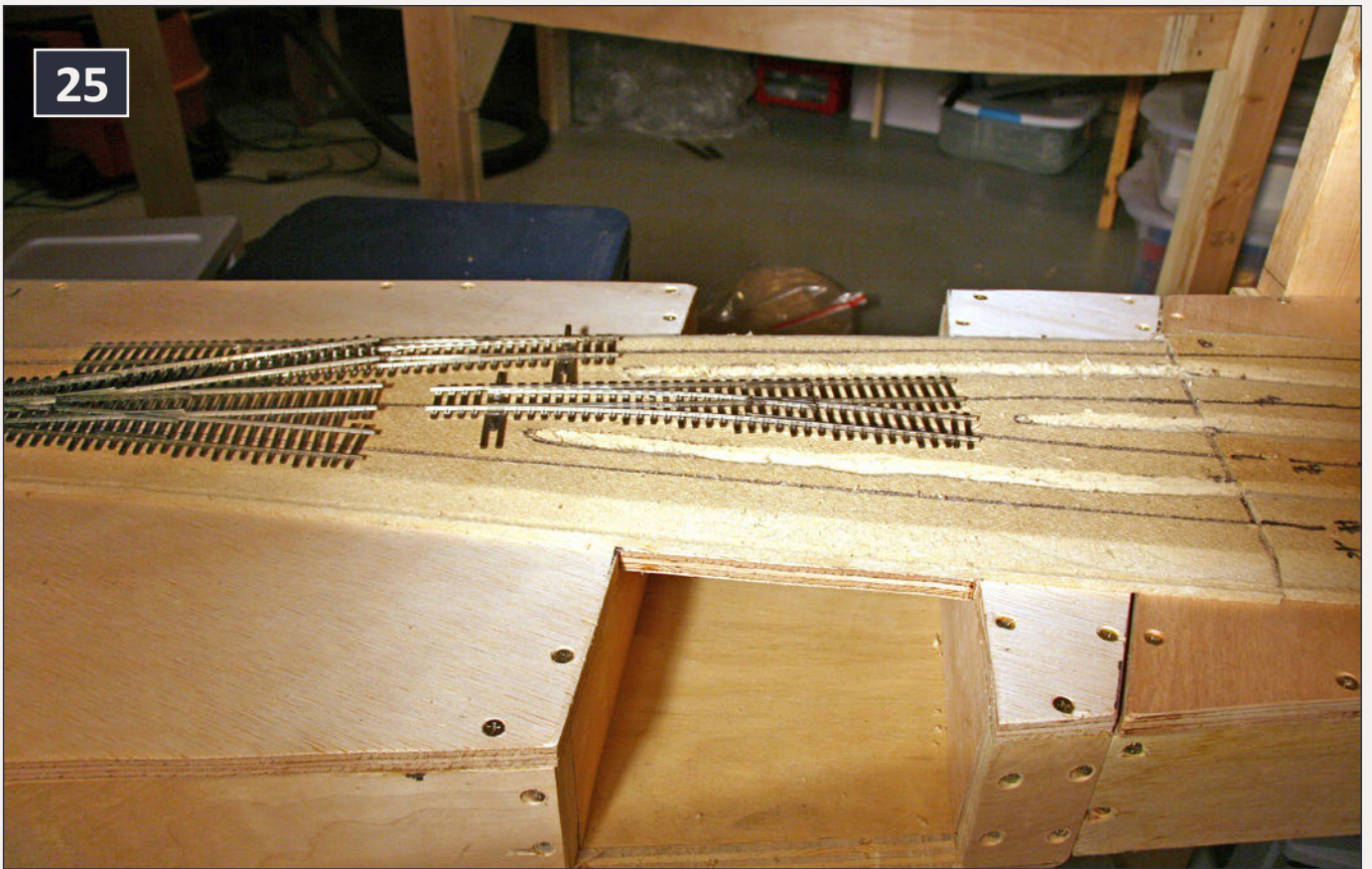

25

25: Deramus yard north throat roadbed complete.



26

26: Roadbed at Shreveport Union Station.



contents



index

mean spray-painting the clouds in the basement, which creates a lot of overspray.

Figure 27 shows the curved end of the backdrop at Watts, Oklahoma. The opening cut in the backdrop leads to the helix. A rock cut and tunnel portal will hide this opening. In figure 28 you can see the three support blocks of wood screwed around the bottom, at the top-left, and a vertical support piece mounted behind the right end of the Masonite panel. The blocks at the bottom will be hidden by scenery. If one or more create a problem, they can be unscrewed and removed.

Creating the fascia

With the backdrop pieces cut and fitted the next step was to fabricate and apply the 1/8" tempered Masonite fascia pieces. I cut the fascia pieces into long strips to the approximate



27: Backdrop at Watts, Oklahoma.



28: Backdrop supports at bottom and behind joint.



29: Backdrop support at the top.



contents



index

height. I then brought them down to the layout room and clamped them temporarily to the face of the layout. I marked the scenic contours onto the Masonite pieces following the contours of the benchwork and the overall plan for the scenery. Next I removed the fascia sections and took the pieces to the shop. I used a jigsaw to cut them to shape. Back down in the layout room again, the pieces were glued and clamped to the layout using Liquid Nails Project Cement. Let the cement dry overnight (31).

An overview of the layout with fascia and backdrop pieces in place is shown in figure 32.

At the sharp front corners of the layout, the edges of the Masonite pieces were mitered (33). The 1/8" Masonite is very flexible and fits nicely into the curved sections of the



30: Backdrop supports between Shreveport and Watts.



31

31: Installing the fascia.



32

32: Fascia installation complete.



contents



index

benchwork as seen in figure 34. I then painted the new fascia a dark forest-green to match the existing fascia (31). Dark brown or gray would also be suitable. The main thing is to use a color which will not stand out and distract the viewer from the layout above!

Painting the sky and clouds

Now it was time to remove the backdrop pieces from the layout. I placed a drop cloth on the shop floor, laid the pieces out and painted them “blue.” The original article on spray-painting clouds appeared in *Railroad Model Craftsman*, April 2001, by Fran and Miles Hale, with John Lawrence, “Stencil Painting Clouds.” They specified Sherwin Williams “Universe Blue.” This is not currently a valid color name with Sherman Williams. I took a piece of Masonite which was painted with the original color down to be matched in Parker Paint. The



33: A clear 1” acrylic rod supports the corner.



34: Curved fascia sections.

match was excellent. Below are the color specifications for that match (35).

Parker Paint; Base:Wht 3650, Interior/Latex Flat Wall Kolor

	Ounces	Shots	Hair Shots
B		33	1
D		23	
E	2	18	

I also found the following Sherwin Williams formula online;
Per John Lowrance at New London Industries

RECOMMENDED BLUE PAINT FOR BACKDROPS:



contents



index

*Sherwin Williams, Super paint Interior Flat Latex “Tint-A-Color” base #6405-12877 “Extra White” mixed to custom color #1792*R BONNET BLUE. The colorant mixture for this paint listed on the can is:*

*Tint-A-Color 1792*R Bonnet Blue*EW*

COLORANT 02 32 64 128

R3 Magenta - 13 1 1

L1 Blue - 52 - -

This paint color is recommended for the following reasons:

1. It contains no green pigments (green gives a “sick” unnatural look to sky backdrops)
2. It is dark enough that the white clouds will show even when painted with very thin sprays of white paint



35: Backdrop section painted “blue”.



36: Custom cloud stencils.

3. It starts dark enough to allow backdrops to be darker at top (where few clouds are painted) to lighter at horizon (where more clouds and white paint over-sprays of cities, mountains, hills, etc. will lighten the sky at the horizon level)
4. It is dark enough (even at lightened horizon line) that it does not “wash out” when exposed to photo lights, flashes, etc.
5. It is available anywhere in the United States of America and many foreign countries



I then painted the clouds using Krylon flat white spray paint as described in the original article. The detail in commercially-available stencils seems too coarse for the multiple puffy clouds of the Midwest and South. I created stencils by projecting a slide with clouds from that region onto card stock. I then cut the pieces apart in layers and affixed them to additional pieces of card stock. The layers are numbered in sequence so that I can start with the top larger clouds first and work my way down to the smaller flatter clouds at the bottom. I made two different sets (36).

It was very convenient to take the pieces outside and to fasten them temporarily in place on our white fence. Also it's a great way to dissipate the fumes and white overspray, on a white fence, will be not be a problem. The exception was my first effort to paint storm clouds using light and dark gray spray paint on the left (Watts, OK) end of the backdrop. I used a drop cloth behind the Masonite in this area to protect the fence from dark gray overspray (37).



37: Painting the clouds, storm clouds to the left.

Start with the stencils with the largest clouds toward the top, holding them an inch or two away from the backdrop to soften the edges. Spray along the edge of the stencil, shaping the tops of the clouds, and allowing the lower portion of the cloud



38: White cloud backdrop section.

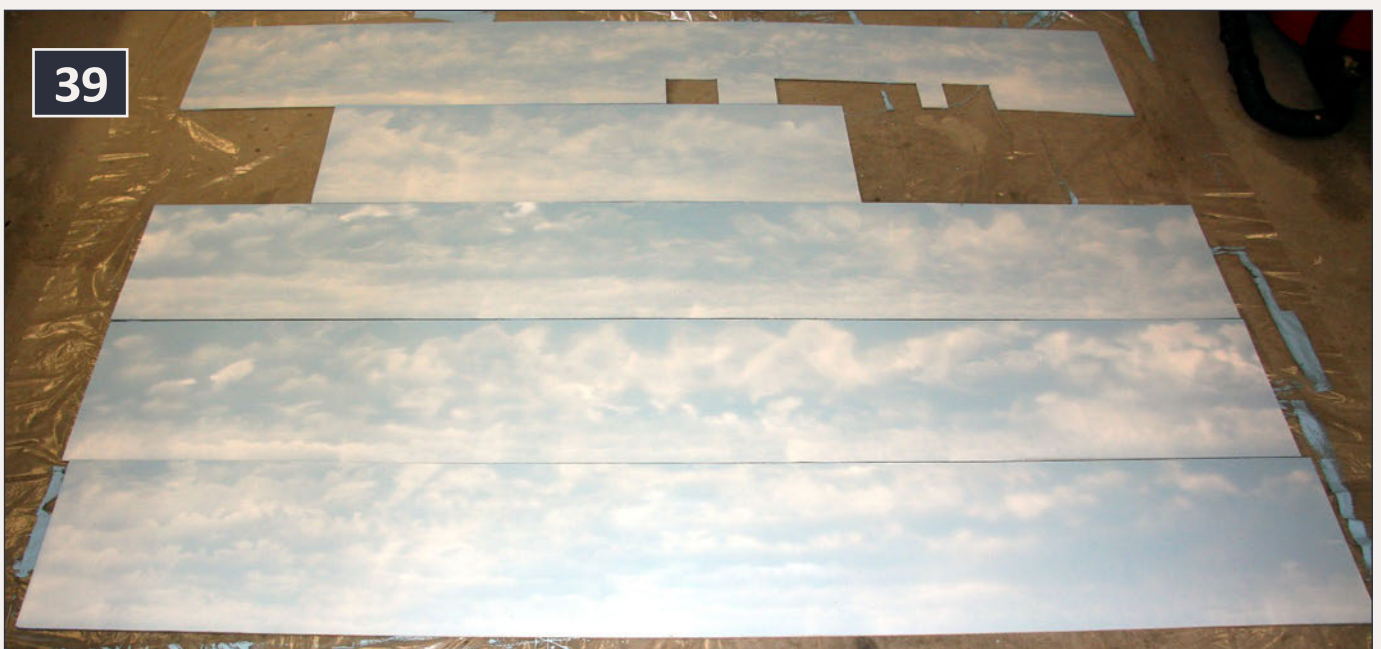

39: Finished backdrop sections.



contents



index

to remain soft as created by the falling overspray. Using the stencils in order, keep moving down the backdrop to smaller and flatter clouds. Mistakes will happen and they can usually be fixed with a little freehand work with the spray can. I use a detachable handle on the spray cans. It makes them easier to control, and the built-in trigger helps to relieve hand fatigue (37).

I use sticky notes above the sections of the backdrop, to mark locations on the layout, so that if I wanted more clouds over the swamp and fewer clouds over Vivian, Louisiana, I could tell where that should occur (38). I try to vary the cloud patterns as I move across the backdrop so they do not all look the same. I create bigger clouds in one section, smaller clouds in the next. More clouds here, fewer clouds there.

Light the lower level

The next step was to provide lighting for the lower level of the layout. I had thought repeatedly of how to do this. The main layout room is lighted using incandescent fixtures which are easy to dim, and to my mind provide a nice feeling of warm bright sunlight. However, under the upper deck of the layout there really isn't a lot of room for incandescent fixtures, the heat they generate would be a problem, and I have pretty much used up the amps available on the breaker panel!

My good friend Al Carter came to the rescue, encouraging me to try the new LED strip lights. The Warm White color, which is available now, is a nice match for the incandescent light in the room. The strips come in 16' (5 m) lengths. The cost is approximately \$8, or about 50¢ a foot. The LEDs are divided into groups of three, and the strips can be cut apart at any of these junctions. Power for the strips is 12 V DC (40).

40



40: LED strip lights, 15' long.

41

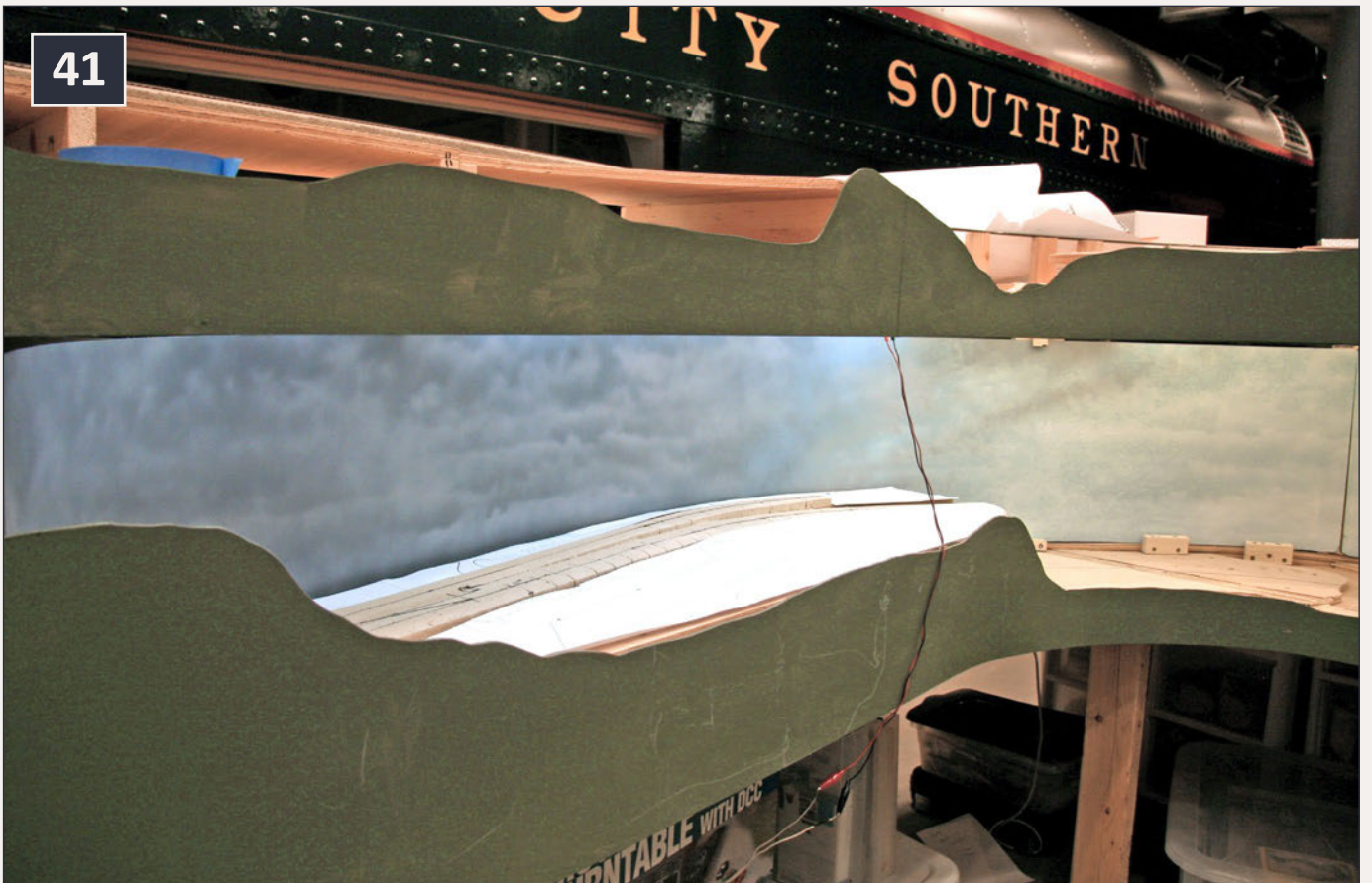

41: Cool white LED's, left fade to warm white LED's, right.



contents



index

What I learned is, that with the Golden White LEDs, the strips must be placed about 6 inches apart to produce a lighting level on the lower deck that matches the overall lighting level in the room. This means that for the average section about 18 inches deep, a strip is required at the front, middle, and back of the upper benchwork to provide adequate lighting. The peel-and-stick backing does NOT hold well. Put it up in the evening and it has fallen down by morning. I used a staple gun and 3/8" staples to fix the strips in place. I placed the staples between the LEDs to avoid damaging the LEDs. In all the strips I stapled in place, I damaged only two LEDs.

One change in plan involved the stormy sky over Watts, Oklahoma. This area will be set in the winter season with snow on the ground. Normally I avoid "White" LEDs. They tend to have a blue tint and overall cold-white appearance. But for this section I used the White LED strips which give an



42: Completed backdrop section under warm white LED lighting.



43: Warm white LED strips 6” apart to light the lower deck.

overall cold wintery feeling to this area. See figure 41 with the Blue White LEDs at the left, transitioning to Warm White at the right. Overall Warm White lighting balance is shown in figure 42.

The underside of the upper deck, with the three LED light strips installed, is shown in figure 43. The next step was to provide for “Blue” night lighting to match that in the rest of the room. I was surprised to find that, for this application, a single strip of blue LED lights was sufficient (44). I was also surprised to find that the blue light includes quite a bit of ultraviolet. This causes any paint or finish that would glow under “black light” to glow. You could capitalize on this effect, if desired. The great John Allen used black-light effects extensively in the Port area of his Gorre & Daphetid layout.

Last, I decided to add red lighting to match the red dawn and dusk lighting in the rest of the layout room. In this case, a last-minute decision was made to put the red lights on the layout deck shining up instead of on the top facing down. This will require careful consideration in the placement buildings and



scenery, but I think the effect of sunrise behind trees/buildings/hills will be worth the effort. All this was made possible because of the ½” width of the LED strip. Incandescent or fluorescent red lights, would require a much greater depth to accomplish this. I have placed some boxes in front of the red LED strip (in the center of the photo) to simulate what the glow on the horizon would look like behind buildings and hills with the LED strip hidden behind them (45).

A serendipitous result was achieved turning on both the blue lights above and the red light below. This provides a very nice red/violet/blue transition between night and dawn lighting (46). I was also amazed to discover that the Warm White, Red and Blue strips make up a total of about 10,000 LED’s! Only today’s cheaper prices make this cost-effective. On an average, using three Warm White strips, one Blue and one Red strip per foot works out to about \$3 per lineal foot.

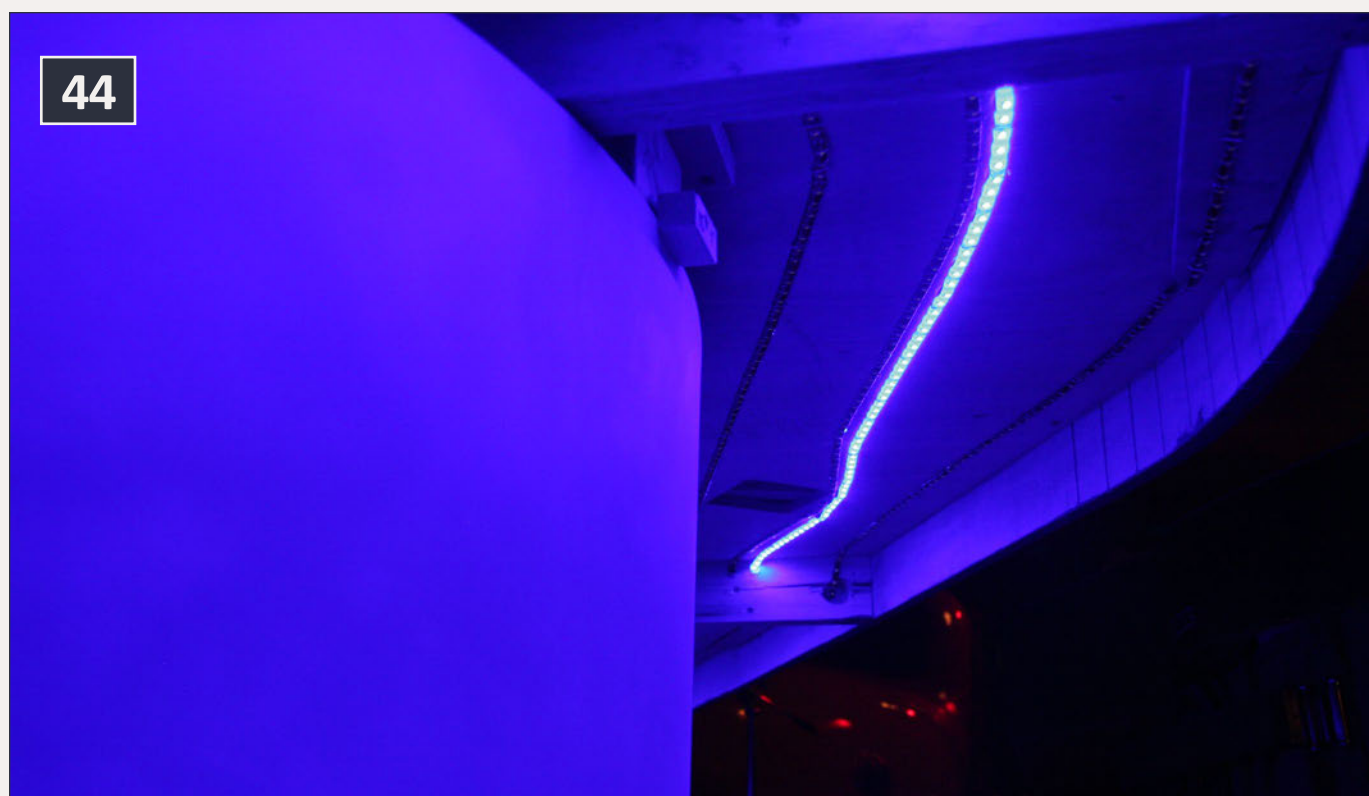

44: Blue LED strip for “night lighting”.

45



45: Red LED up lighting for dawn and dusk sequence.

46



46: Red and blue LED lighting together yields the “purple shades of night”.



contents



index

The last issue is providing power and dimming for the LEDs. That's not much of a problem for the single strip red and blue LEDs. For these I purchased two 12 vdc 2 amp power supplies for six dollars each. However to power the 6000 Warm white LEDs at 1 milliamp per LED works out to 6 amps! So the usual 3A RadioShack wall adapter won't handle the load! A 12 vdc 20 amp switching power supply costs \$33. The three dimmers will handle up to 8A and cost \$5.50 each. I ordered all of the LED strips, power supplies and dimmers from Amazon.com.

On to track laying

So with this installment, the benchwork, roadbed, backdrop, fascia, and lighting are complete. Now it's time to lay track, install wiring, and ballast. Did I miss something? Oh yes, run trains! 

Advertisement

RailPro™

NEW TECHNOLOGY



**Click here
to watch
our videos!**

New Products

- Accessory Module
- Auto Reverse Module
- New Sounds and more!

For more information visit our Internet site: www.RingEngineering.com



Email



Phone



contents



index

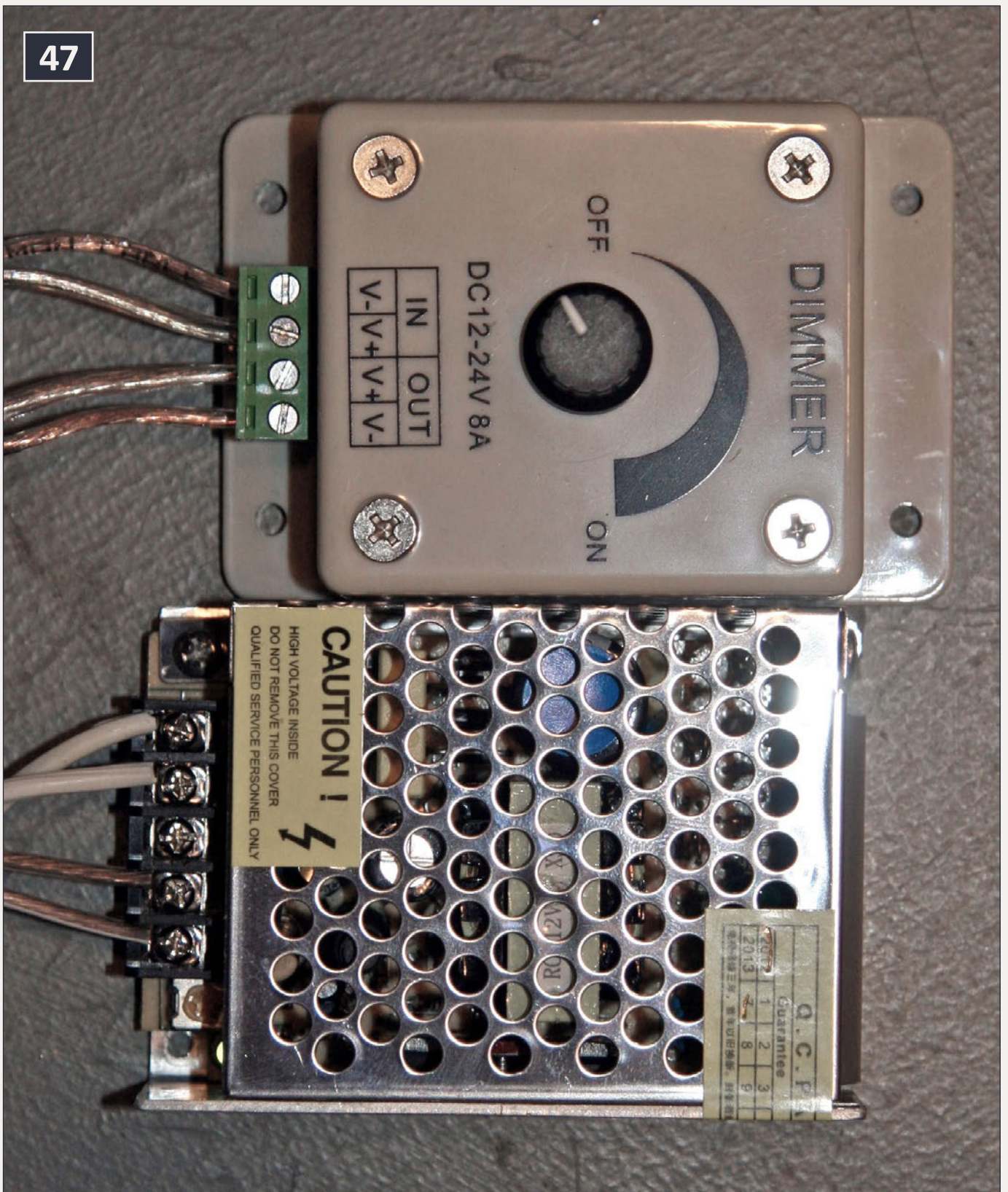

47: LED dimmer and power supply.



Reader
Feedback
(click here)



contents



index

Bowser

EXECUTIVE LINE

New Product Announcements!!

HO C430 Locomotive



HO H30 Covered Hopper Cars

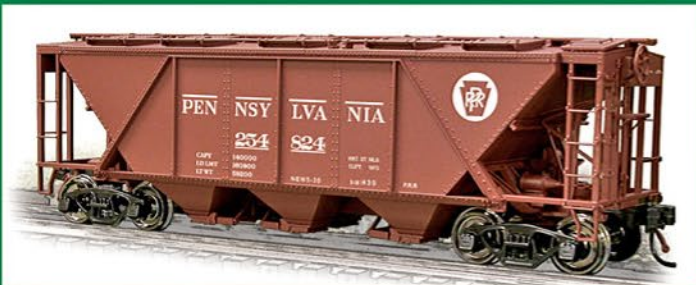

HO New Orleans Streetcar



Click here for more information and to sign up for our email newsletter to get the latest news about these and other great Bowser products



Get Better Sound from your Locomotives

Can't get a good sound from your sound decoder?
Give our speakers a test drive with your ears.



RAILMASTER HOBBIES
9815 WALNUT ST #106
BELFLOWER, CA 90706

Bass Reflex
Speakers



High Bass
Speakers



When it comes to speakers we have high quality speakers to fit many different applications. We are also a full line hobby shop. Need anything? We are an authorized dealer for Soundtraxx, Digitrax, Athearn, Walthers and many others. We provide quality speakers for your DCC sound systems and quality service.

**Click here for
the *sound* answer ...**





Freight cars of Jeff Meyer

Photos and video of awesome models

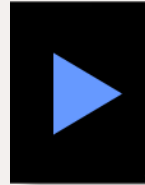

**Reader
Feedback**
(click here)



What's neat this week column

by *Ken Patterson*

1



1: In this column I'm showing off Jeff Meyer's freight cars in modeled scenes. Click on the feedback button above to encourage Jeff to do an MRH article on freight car weathering ...



I first met Jeff Meyers at the 2011 Railroad Prototype Modelers (RPM) meet in St Louis. Jeff, a locomotive engineer, has been modeling since he can remember, but only got serious about freight car modeling in the past six years.

Jeff acts as a moderator on the **The Weathering Shop – Rust Bucket** website (tw-s-rustbucket.com). He attributes most of his enthusiasm and newly-honed weathering skills to the information he's gained from his association with the Rust Bucket site.

I had the chance to shoot photos and video of Jeff's freight cars in modeled scenes this past summer, so I'm presenting you with the results of our time together, along with a brief description of what went into making these fine looking HO models. I'm also inviting Jeff to write some step-by-step articles for MRH on how he models and weathers his freight cars.

Enjoy these photos and video of some very inspiring modeling!



Playback problems? [Click to try a different version.](#)



contents



index

2



2: This ACF RailBox started life as an Atlas kit before Jeff turned it into this amazing model. He used many details including Sergent draft gear boxes and scale couplers, Plano pin lifters and crossover platforms, Hi-Tech Details air hoses as well as stirrup steps, brake rigging and scale wheelsets! Jeff used a flame to create a bit of a roof bulge per the prototype. This model represents many hours of work.

3



3: Jeff tricked out this Walther's waffle side box car with an array of details that include: tack boards, grab irons, stirrup steps, scale wheelsets, air hoses and coupler pin lifters. Jeff left the factory paint but weathered the car with oils and chalks.



4



4: This DRG&W Box car is an Athearn Genesis model. While already a highly detailed model out of the box, Jeff added still more details such as new wire brake rigging underneath to better match the prototype as well as Hi-Tech Details real rubber air hoses. Jeff added the proper stenciling and weathered the model with oil paints giving a very accurate representation of its prototype.

5



5: Atlas makes this PRR 3 bay ACF hopper. Jeff used Hi-Tech Details air hoses, Plano roof walk, plus grab irons and pin lifters. Jeff weathered this model with oils and powders.



contents



index



6: This PC gondola is one realistic freight car! Jeff's model started as a Tangent kit. He used a flame to soften and buldge the sides of the gondola's panels to represent wear.



Jeff achieved the PC green faded effect using zinc white oil paint. Saw dust and ashes provided the interior debris, and Jeff got the rust effects using oil paints and chalks.



contents



index



7: Jeff's Atlas 89 foot model of a DTI piggy-back flat car looks great with its realistically rusted and weathered deck. He used dry transfers to get the new stenciling for DTI. For this car, Jeff set up the hitches to handle dual 45 foot trailers.

Would you like to see Jeff do some step-by-step articles of his techniques for Model Railroad Hobbyist? If so, click the comments button below and post a note encouraging Jeff to write something up for MRH and send it in!

Reader Feedback



(click here)

NEW FROM ACCURAIL

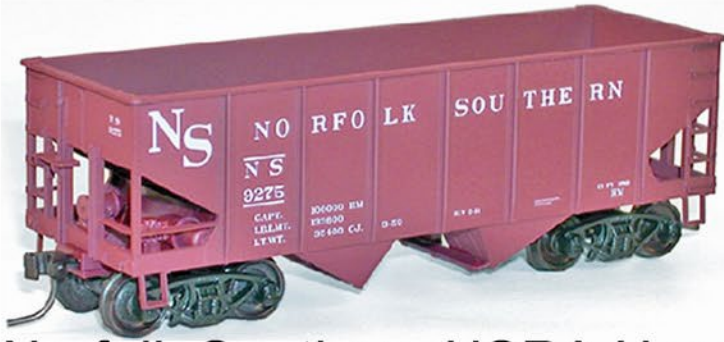

EASY TO ASSEMBLE HO SCALE KITS

Join the Accurail Mailing List for the latest announcements & upcoming releases



Norfolk Southern USRA Hopper
3-Number Set
Also available as singles



Toledo Peoria & Western
50' Box Car



Maine Central
40' Wood Stock Car



Lackawanna 40' Steel Reefer



American Refrigerator Transit
40' Steel Reefer



Limited Run
Union Pacific 3-Number Set
40' PS-1 Steel Box Cars

PLEASE SEE YOUR LOCAL HOBBY DEALER
OR CALL 603-965-1173 FOR DIRECT ORDERS



contents



index

Rslaserkits



On30 Pickle car



click here

Stop by and see us
At the Amherst show
In West Springfield, MA
January 26-27

Pre production photo
Final kit to have more
parts then shown.



Fugate Farm Supply

One of the new kits to be released at the Amherst Show
Let us know if your planning on picking one up at the show
so we will have enough with us.

Custom Laser Cutting and design
Dealers welcome



5145 Gaffin Rd. SE • Salem, OR 9317

(503) 371-4290

• Fax: (503) 585-0850

E-mail: Sales@rslaserkits.com

Web site: www.rslaserkits.com



BI-CENTENNIAL. BECAUSE AGE IS A THING OF BEAUTY. AVAILABLE AT BETTER STOCKED WALTHERS DEALERS \$39.99* for a really limited time. TLT 999002 GTW BI-CENTENNIAL CABOOSE



**Preproduction units shown. Final product may differ*

TRUE LINE TRAINS

QUALITY BEYOND COMPARE

**CP EXPRESS BOX CARS!
WITH AND WITHOUT AN
ACTION RED STIPE!**

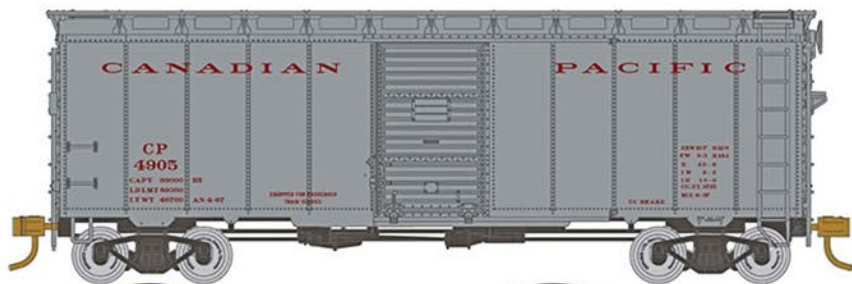
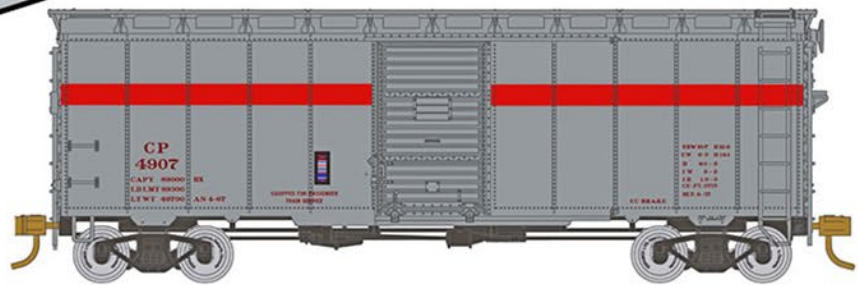

**LIMITED PRODUCTION
(and we mean limited)
AND ONE RUN ONLY!
DON'T MISS YOUR CHANCE TO
REALLY COMPLETE YOUR CANADIAN!**



For More Info, Please Call (905) 738 - 6556

True Line Trains Exclusively distributed in Canada by Canadian Hobbycraft Limited 445 Edgeley Blvd, Unit #1, Concord, Ontario L4G 4K1

Click this ad to visit our website ...



MRH HOBBY MARKETPLACE - 1

CLEVER models LLC
 PAYLOADZ PAYPAL
 O,HO,S,N

CRAFTSMAN CARDSTOCK models
 PRINT, CUT, FOLD & PASTE
 FAST, FUN RESULTS.
Most kits under \$10.00

Order online, DVD's and Instant downloads
www.clevermodels.net
 Finished model exactly as shown no additional weathering required



True Scene Modeling™

NEW FusionFiber™
 Dependable Quality. Easier than Plaster!
SATISFACTION GUARANTEED!
www.truescene.com or 716-523-7305

Backdrop Junction
 Your stop for
Model Railroad Backdrops



[click here to visit our website](http://www.backdropjunction.com)
backdropjunction.com
 N, HO, O Scales • Custom Orders

click here! Recommended installation tool

Goes on easy

All Scales
 All Brands

Make a Tire or Retire

BULLFROG SNOT

SNOT = SAND

99% Know It Works!

Green Grip from a Jar
WWW.BULLFROGSNOT.COM



Minimalist Model Railroading

New Approach to Model Railroad Design

[Click here to learn more...](http://minimalistmodelrailroad.com)

minimalistmodelrailroad.com



REAL CEDAR TRUNKS
Click Here!



Jelsma Graphics
 AMERICA'S NUMBER ONE RAILROAD PRINT SOURCE
 ...America's Railroad Embroiderer

Railroad Art-Prints, Caps, Jackets, Shirts and More ...
 Jackets starting at \$79.95

www.jelsma.com
 1-904-221-3513 • Jacksonville, FL.

Looking for a signaling solution or fast clocks? Look no further!

LOGIC RAIL™ TECHNOLOGIES "Sophisticated Model Railroad Electronics"

Please visit our website and online store!

21175 Tomball Pkwy Suite 287 Houston, TX 77070
 Phone: (281)251-5813
<http://www.logicrailtech.com>
info@logicrailtech.com



MRH HOBBY MARKETPLACE - 2

Affordable custom and modular benchwork.

MODEL RAILROAD

BenchWork.com

You won't **believe** everything this model RR software can do ...

Show me
(click here)

StansTrains.com



The Age of Steam & Steel



RAILROADING 1832-1949 4-DISKS

**CLICK
HERE**

W

GOLDEN AGE LINE
WESTERFIELD
MODELS, LLC

Available Again



#3200 Series H21 / H21A
More RI Stock Versions Soon
westerfieldmodels.com

ON3 - ON30



Click to visit ...
WWW.SANJUANCARCO.COM

HOBBY MARKETPLACE ads are economical and effective.

Click HERE to learn more.



MRH HOBBY MARKETPLACE - 3

STREAMLINED BACKSHOP SERVICES

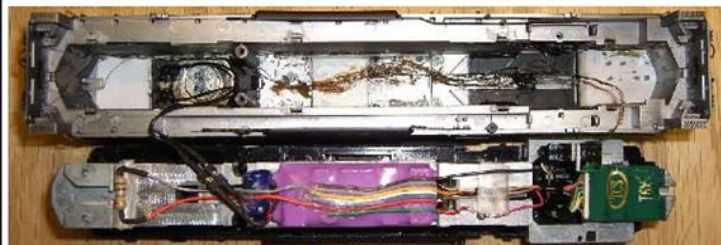
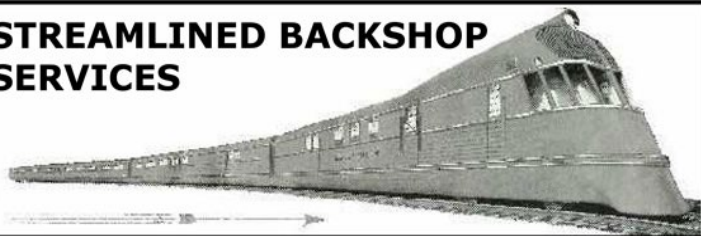

Z-N-HO-G DCC INSTALLATIONS



www.SBS4DCC.com

Great Decals!

is now selling decals produced by *After Hours Graphics* for Midwestern railroads. Roads offered include C&O, Cincinnati Union Terminal, Conrail, CSX, DT&I, Great Miami, Indiana and Ohio, Interstate, NKP, Norfolk and Western, Pere Marquette, Southern, Transkentucky, and private labels Dow and Owensboro Grain.

For the complete list, see:

www.greatdecals.com/AfterHours/AfterHoursList.html

Great Decals!

P. O. Box 994, Herndon, VA 20172

RULERS of the WORLD

Scale Rulers \$4 each

Over **150** scales!

Metric or Imperial

www.rulers-of-the-world.com

Your Text Ad

Could be here for a remarkably affordable price!

mrhmag.com/advertise_with_us

The Proto:87 Stores

21st Century, Model Railroad Miniature Engineering for everyone. Actually making your model track and control systems look and work the way the Prototype does. All without needing craftsman skills, or crawling under your layout.

www.proto87.com

Get your ad here ... click to find out how.





Installing DCC sound just **NOT** your thing?
Trust Traintek for sales and installation of sound
decoders from these fine vendors!



RailPro™

*"Taking model railroad control
to the next level ..."*



traintekllc.com

Click here for more details...



"Traintek **was** the
way to go!"



Visit Tony's Trains

SEE TONY'S AT



"Big E"

W. Springfield, MA, Jan 28-29

- QSI Sound Demos
- Show Specials
- Big DCC Inventory

- * FIRST in DCC Sales & Support
- * Installations and Loco Work
- * Club Demos & Discounts
- * We Guarantee Your Satisfaction



The New Cool NCE DCC Twin Set!

A Cool 3 Amp DCC Starter Set with two throttles in one box. It is great for someone buying their first Train Set. The Twin is designed to grow with your layout. It has an expansion port that allows

List: \$159.95.00



Click here to
Visit Tonys' Website



Exchange Website today!



Pinewood Plaza 2/13
57 River Rd, Box 1023
Essex Jct, VT 05452

info@TonysTrains.com
fax 802-878-5550

Great price!

Great performance!

additional NCE devices such as full featured or engineer style walk around throttles to be added to the system. The DCC Twin also includes an Eco friendly power supply. Wireless and PC upgrades available!
Tony's: \$124.95

- ★ Discount Prices, All Scales
- ★ Digitrax Zephyr \$179.95
- ★ Sup E. BlderX \$284.95, Radio XD \$459.95
- ★ Sup ChiefX \$369.95, Radio XD \$529.95
- ★ NCE PowerPro \$412.95, Radio \$569.95
- ★ NCE PowerCab \$155.95
- ★ MRC Prodigy Advance-2 \$254.95,
- ★ QSI Titans \$103.95
- ★ Soundtraxx Tsunami AT, BW, GN, \$81.96

800-978-3472

INFO, QUESTIONS, CATALOGUE

TonysTrains.com



Click here to Start saving today!





A better jeweler's saw

Tired of jeweler saw blade breakage? Here's one way to minimize expensive blade breakage, permanently ...



by Jack Burgess

Railroad modelers tend to have one or possibly two hand saws. Based on kitbashing articles, it seems that the most popular hand saw is an X-Acto Razor Saw or equivalent. I have one of these saws, but since I don't kitbash, I rarely use it.

The other popular type of saw is the jeweler's adjustable saw. These saws are designed to cut intricate external shapes and interior cutouts. They use thin blades held in an adjustable frame which permits blades to be drawn taut. Since the blade can be removed from the frame, this saw can also be used to cut an opening in the middle of a piece by passing the blade through a hole in the piece and then re-attaching the blade to start cutting.

Like many modelers, I purchased a jeweler's saw many years ago. To use one of saws requires that you first clamp each end of the blade to the frame. But it can be difficult to clamp both ends of the blade so that it is parallel with the frame and thus not unevenly stressed. Once the blade is properly in place, the frame



1: This is the Knew Concepts jeweler's saw. The frame is laser-cut from aluminum. According to the manufacturer, "...red colored handles are used because clinical trials have shown that the color red promotes accuracy."

is extended as needed to put the blade in tension and the frame locked into place. If the saw frame flexes or the blade flexes too much, the blade can easily break. It is exasperating to put a new blade in place, tension it as much as possible, and then have the blade break part way into the project due to flex. Other times, the blade would pop out of the clamps as I tried to tension the saw frame, another aggravation.

The shortcomings of my inexpensive jeweler's saw could probably be overcome by taking more time to carefully position the blade in the clamps and tension the saw frame as much as possible. But I don't have much patience, especially when it comes to the tools that I use. Instead, I prefer to replace the tools that don't meet my expectations. After all, this is a hobby and I don't like to use tools that cause me frustration.

I found a replacement jeweler's saw at Otto Frei, a jeweler's supply company in Oakland, CA. It is a saw frame made by Knew Concepts of Santa Cruz, California. Here is a link to the saw



contents



index

frame (item 149.653): ottofrei.com/Knew-Concepts-Jewelers-Precision-Hand-Saws-with-Knob-Tension.html.

The design of this saw frame is absolutely rigid, minimizing saw blade breakage. Blade placement is simplified by a design in which the ends of the blade are inserted into small holes and clamped into place. This eliminates the problems associated with the blade not being parallel with the frame. Once the blade is clamped into place, it is tensioned by a spring-loaded knob on one end of the frame. Much simpler! These saws are made in the USA using only USA-made parts including the screws. The saws use the same small blades as the hobby-quality jeweler's saws.

These saw frames cost \$47 each compared to about \$15 for the standard hobby-quality saw frame. I think that the differ-

Advertisement



Click Here

FIFER HOBBY SUPPLY LLC

**Your Local Online
HO & N Scale Hobby Shops**

575-523-9743 • fiferhobby.com • fiferhobbyho.com



ence in cost between a quality tool and the less expensive tool is appreciated every time you use the tool.

Disclaimer - I love good tools and don't hesitate to invest in them.

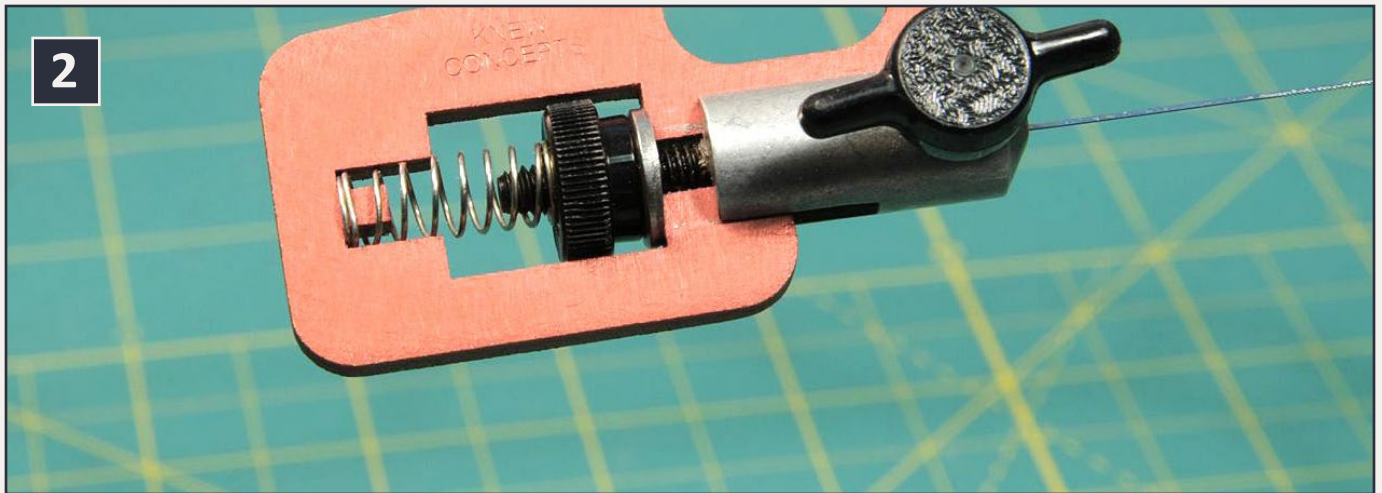

2: A close-up of the blade holder and tension adjustment. The blade is inserted into a small hole in the grey-colored collet and locked in place with the black clamp screw. Blade tension is then adjusted with the spring-loaded adjusting knob. The blade should be adjusted until you are satisfied with the “ping” when the blade is flicked with your finger.



contents



index

Yes, it's a model

**Model Railroad Hobbyist's
monthly photo album**

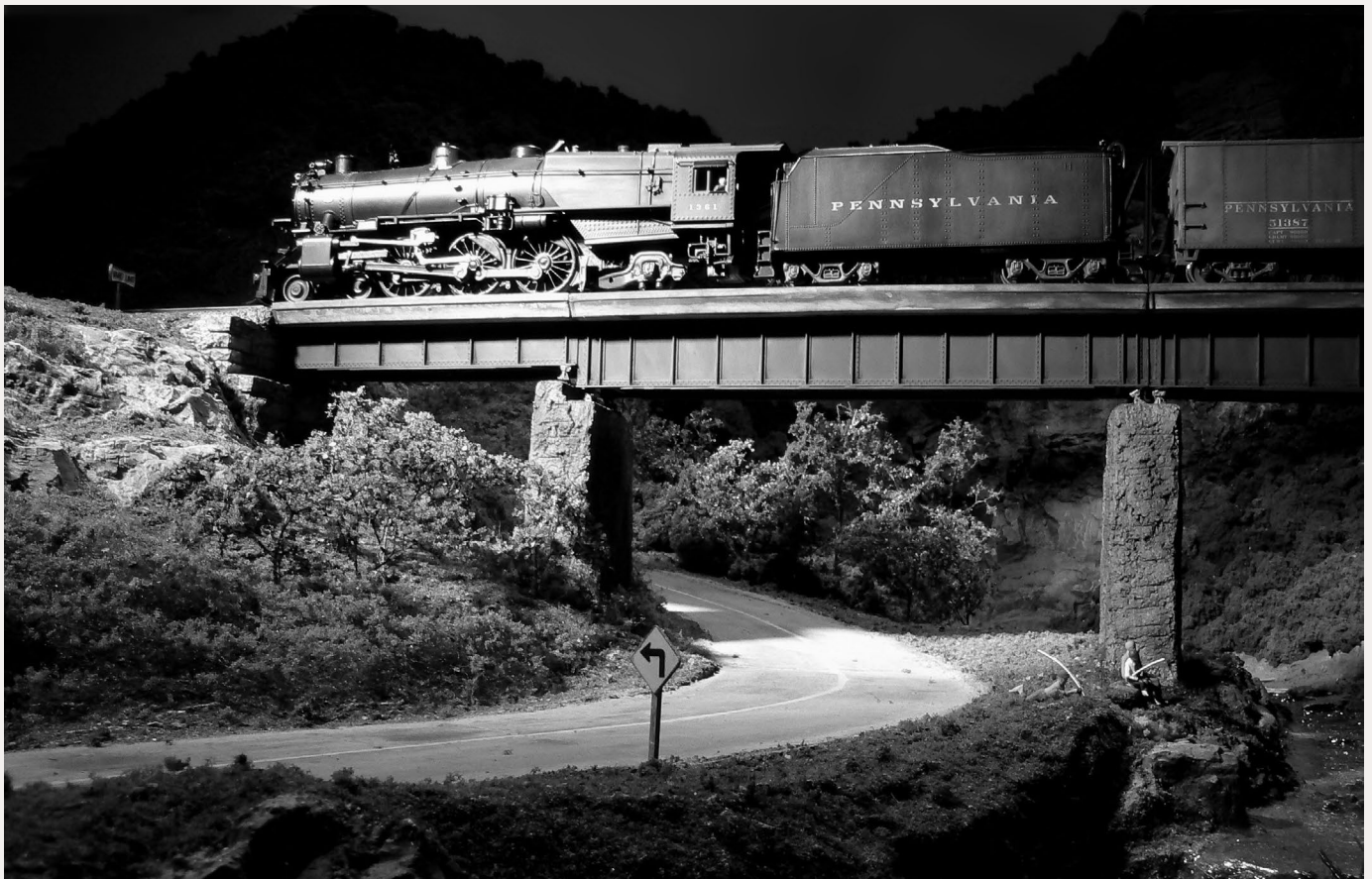

Shades of O. Winston Link's prototype night black and white flash photography, we found this model photo by Jay Herr of his HO layout really jumped out at us. Jay posted this photo on MRH's [Weekend Photo Fun](#) thread recently, and he told us he was "just experimenting" with interesting photographic lighting. Jay had never seen O. Winston's photos, but we think Jay's modeling and photography capture this look superbly for a model. Very nicely done, Jay, and we look forward to seeing more of your layout!





Kevin Packard writes, “This car started out as Walthers’ 50’ Airslide. I was inspired after seeing Tom Zarnock’s incredible Proto:87 Airslide build and used many of his tricks and techniques on this. I completely redid the details on this car, replacing cast-on detail with separate detail all around the car. I traded the stock trucks with semi-scale Athearn Genesis trucks. Finally, I painted and decalled the model.

“I *always* work from a prototype picture when weathering. Even if it isn’t an exact copy of the car, looking at prototype pictures is the *only way* to ensure that your weathering patterns are realistic. [We heartily agree. – MRH]

“Good places to look for pictures are rrpicturearchives.net, locophotos.com, railcarphotos.com, and railpictures.net. There are many other websites that have a bank of prototype pictures including websites like protomodeller.com and theweatheringshop.com.”



contents



index



In the top photo, Canadian National #2000, an ALCo Century 630 variant built by Montreal Locomotive Works (MLW), rolls past MLW RSD-15 while it switches cars at the Ste-Rosalie grain silos. This is “Chemin des Seigneuries” crossing at Ste-Rosalie on the [HO Bonaventure & Chambly \(BOeC\) of Sylvain Duclos](#).

Sylvain’s Bonaventure & Chambly represents the St-Hyacinthe subdivision and also part of the Drummond Sub of the Canadian National. The focus of his layout is freight and passenger operations on the CN, VIA rail, and a fictitious short-line, the SL&C.

Speaking of the SL&C, take a look at the rust weathering on that SL&C cylindrical covered hopper closeup in the second photo. That’s one of the most realistic rust jobs we’ve ever seen on a model, truly meriting MRH’s “Yes, it’s a model” label!



We asked Tom Johnson how he did the realistic grain spills here on his Logansport and Indiana Northern layout and he replied, “I used Z scale Highball ballast which is almost like powder. I made the piles, used an eye dropper to carefully apply the water/detergent wetting agent, and then applied white glue mixed with water. After a day of drying, I painted the piles with a dark yellowish brown color to represent the old rotten corn on the bottom and then added a brighter yellow paint on top of the piles for corn that has not rotted yet.”

This is just one of the many photos Tom has posted of his layout on our website. For lots more photos, [visit Tom’s thread here](#).



contents



index



Texas South East number 3 spots cars at Sabine Brass & Copper. This is Len Turner's Texas South East Railroad, a freelance HO scale urban industrial switching layout set in the early 1950's.

Len says, "I based design and construction of the TSE on Lance Mindheim's series of books on small switching layouts [Even though Lance's examples show contemporary railroading, here's a superb instance of applying Lance's design principles to layouts set in the transition era. – *MRH*].

I designed the track plan for industrial switching operations with a full loop main as the switching lead. I designed the TSE to be simple with straight forward switching – no switching puzzles or 'Time-Savers' and so on. The plan includes a three track staging yard and a full loop with two runarounds. The track plan will continue to evolve as I get further into construction of the layout. I used mostly Micro Engineering code 70 Flex track and ME code 70 #6 turnouts. For the yard trackwork, I used Atlas code 83 with #4 and #6 turnouts. My minimum curve radius is 24". For more on the TSE, [see Len's website](#).



Extra 708 West departs Milton, UT and rolls west over Greasewood Trestle through typical northern Great Basin surroundings on Rob Spangler's HO Western Pacific layout.

Rob says of this photo, "This location is tough to photograph because of the limited available angles that don't show where the backdrop curves out of the scene, plus there are shadows behind the trestle that are hard to avoid because of how close the backdrop is. They disappear into the trees if no train is present."

Rob showed how he built this trestle scene [in this thread on the MRH website](#). Rob is a frequent poster on the MRH site and we hope to see him do some articles for us on his scenery construction techniques. In the meantime, make sure and check out [Rob's blog on the MRH site](#).



contents



index



Thomas Gasior recently posted photos of his HO Delaware and Hudson two-tone gray baggage car on his MRH website blog.

Thomas described how he did this car, “One of the layouts I operate on features the D&H and NYC in Albany, NY. Heavy passenger operations require many headend cars. I offered to create a D&H two-tone grey baggage car that the D&H had for a few years. A Walthers 72’ NYC baggage car was the starting point. I took the car apart and used 91% alcohol to remove the lettering. I washed up the sides and applied a coat of NYC light grey, as I like to paint darker colors over lighter ones. After light grey dried, I masked and painted the darker grey. Once everything dried, I applied Highball Graphics decals – the set had the stripes and the car number I wanted plus the little star logo.”

You can see the entire process [here on Thomas’ MRH blog](#).

The model ...



The prototype ...



Joe Atkinson posted this F-unit model and its prototype inspiration on a [recent MRH Weekend Photo Fun thread](#).

Joe says, “I started with an Intermountain F7A in factory MILW paint. I replaced the forward-facing horn and added new cab roof grab irons, antenna w/conduit running between the windshields, cut levers, nose-top grab irons, platform beneath the engineer’s window, number decals, nose lift rings, and MILW herald.

“I modified the skirts and cut in a new nose-mounted MU connection next to the headlight, per the prototype. I touched up the Milwaukee orange paint on the nose lift rings and platform supports using a custom mix of Floquil Signal Red and Reefer Yellow. I painted the wheels Floquil grimy black then added fading and weathering with oils.” Truly worthy of our new “Yes, it’s a model” feature!



contents



index



Charlie Comstock posted this “old-time” photo of the logging spur at Oak Hill on his Bear Creek & South Jackson, his 1950s-something freelance layout.

Charlie said he was “having fun with Photoshop on some older BC&SJ photos”. If that’s what you call fun, Charlie, then go have yourself a ball and post the results on the MRH website! Learn more about Charlie’s HO Bear Creek & South Jackson [here on the web](#).

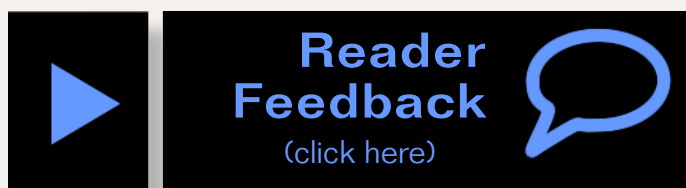

Get your photo here!

Our new *Yes, it's a model* monthly photo feature presents some of the most inspiring modeling and photos from the MRH website. If you'd like to get *your modeling* in our photo feature, just start posting your photos on the MRH website, especially in the [Week-end Photo Fun thread](#) created each weekend.

Most of the photos posted show HO modeling, but we'd like to encourage modelers in other scales to post on the MRH website as well. We don't want this to just be an HO photo feature!

For info on how to post photos to our website, [see this help how-to](#). You need to be an MRH subscriber to post photos to our website, and becoming a subscriber is free, [just fill out this form here](#).

SERIOUS FUN



GREAT PRODUCTS



KATO



EXCEPTIONAL SERVICE



Great products. Exceptional service. Serious fun.™

Find products from over 100 model railroad companies at HorizonHobbyTrains.com. All the brands you love—Athearn,® Lionel, Bachmann and more—are right there. You'll also enjoy:

- Same-day shipping
- Our deal-filled Savings Station
- eGift certificates

Everything we sell is backed by the best customer service and support available. Our service center team is standing by to help you get the most from whatever you buy. At HorizonHobbyTrains.com, we take having fun very seriously.

Visit HorizonHobbyTrains.com. Exclusively Trains.



HORIZON™

HOBBY TRAINS.COM

©2012 Horizon Hobby, Inc. All rights reserved. Athearn, Serious fun and the Horizon Hobby logo are trademarks or registered marks of Horizon Hobby, Inc. All other trademarks, service marks and logos are property of their respective owners. 36139

Click to learn more ...



contents



index

Determine the Best Size for Your Layout Using Op Session Timing



1

by Lance Mindheim

Photos by the author

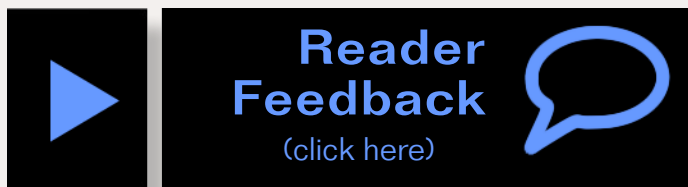

How much layout do you need to accomplish what's important to you, and how much do you *really* need to be satisfied? ...

1: Don't let the single turnout fool you. This warehouse has six doors, each a separate car "spot," that essentially act like mini-industries. You don't just waybill a car to the warehouse; you need to deliver it to a specific spot. Operated in this railroad-like manner, even simple track arrangements can take a half hour or more to switch.



Most newcomers, and many veterans, grossly overestimate their requirements and by doing so create a lot of unnecessary expense and angst for themselves.

Certainly there are many factors that could go into determining how large of a layout you design for yourself. My hunch, however, is that as a hobby we are so petrified that our layout will be too small that we pursue the subject with blinders on. With no basis in reality, many begin the design process from the negative viewpoint that they don't have enough space. Every decision is based on the shoehorn strategy: How do I squeeze in "one more industry, one more turnout."

This panic-driven approach to layout design often results in model railroads that are too large for the individual's lifestyle and frequently never get built. In those cases where the layout does get built, the owner may find they designed in far, far more operational capacity than they could ever hope to utilize. The visual result is a model railroad packed with overly compressed and unrealistic scenes.

Unlike the hobby as a whole, the majority of the followers of my blog (lancemindheim.com/blog.htm) are interested in operations. Many are just starting, or are about to start, construction of their first layout. A fair number of folks have a generous amount of space available. They may not realize it yet, but they do.

So, if your primary interest is operations and space is adequate, how much capacity do you design in? How many industries or car spots do you need to get the satisfaction you want from the layout? If you had a 1,000-square foot basement would you design a layout to use all of it? Of course not. You'd never be able to utilize that much capacity.

To start we need to know a few things:

- How often will we operate alone?



contents



index

- How often will we operate with guests?
- How long do we want an operating session to last?

I'm going to divide op sessions into two types. The first is the full-blown session with guests. Outside feedback continues to confirm that most guests start getting burned out at the three-hour mark. Three hours (or a bit less) is generally the ideal session length when guests are over. The frequency of these sessions with guests should also be taken into account. Despite the best of intentions, for most people these full-blown or guest operator sessions don't happen nearly as often as the builders initially thought, perhaps three or four times a year max.

By far the most common op session scenario is the layout owner running by himself, or it least it should be. Don't fall into the trap of thinking that a session has to be the full three-hour deal with guests versus nothing at all. For planning purposes, assume that when you're running by

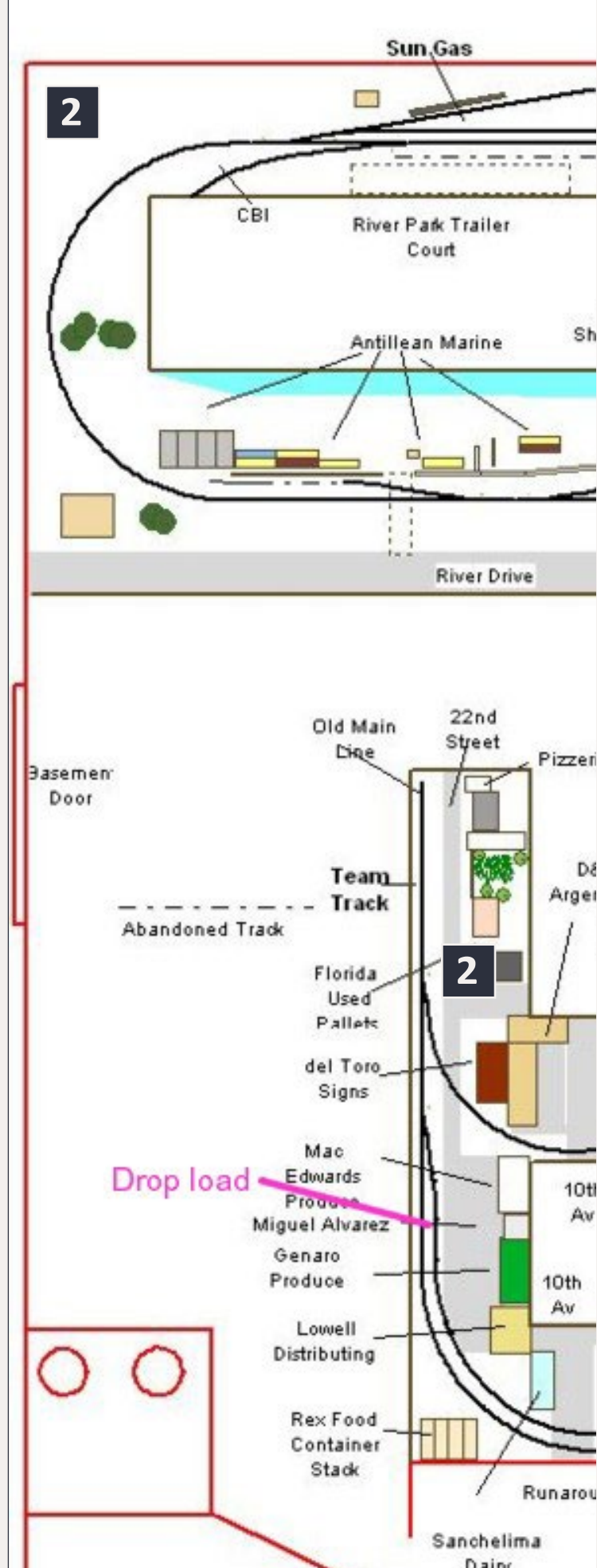

2: The diagram above shows the tasks from my last op session.

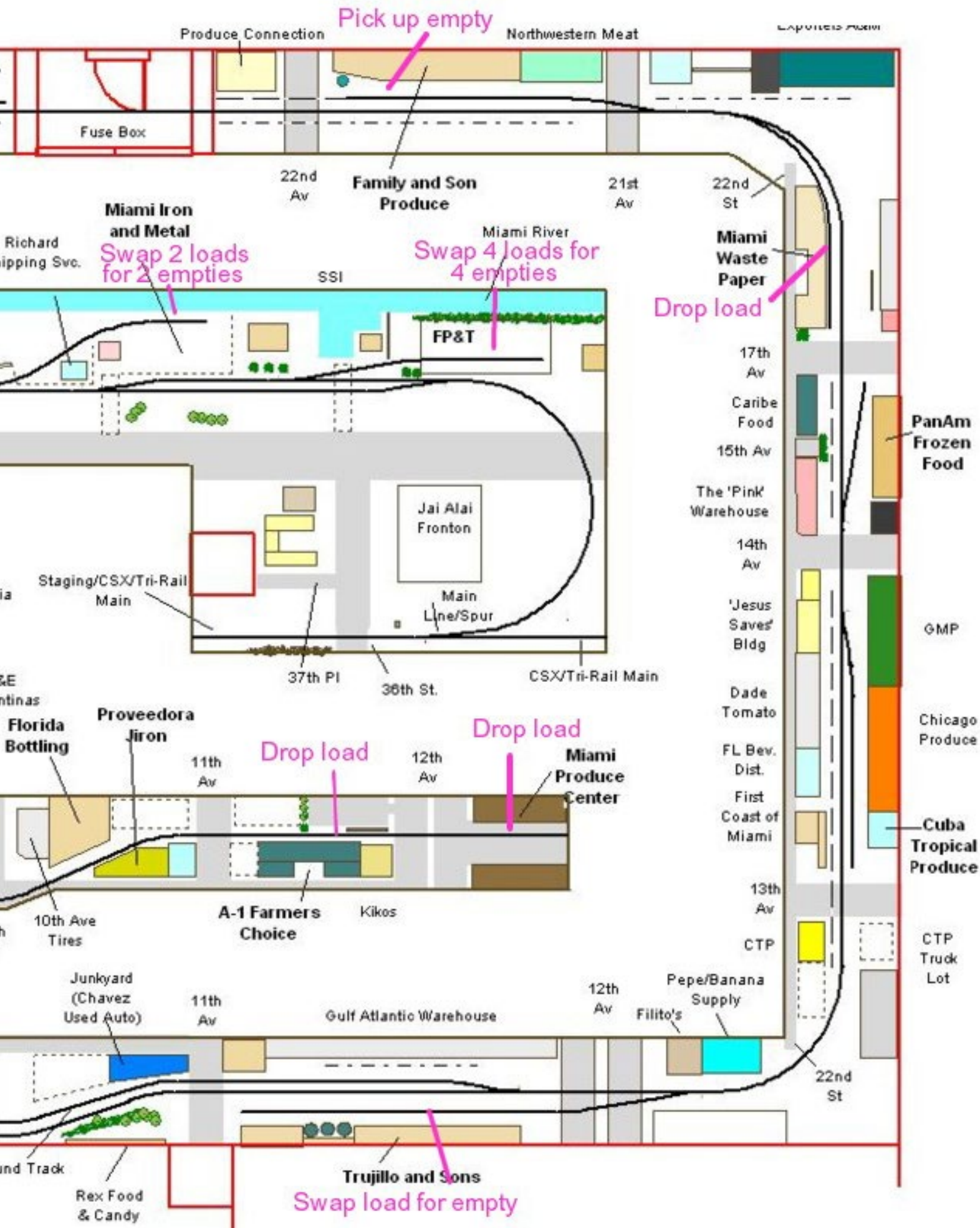

I had a guest over and it took about three hours. There were no tricks or complexities, the guest made no operational errors, and we worked at a realistic but relaxed pace.



contents



index

yourself that you go for 20 minutes to an hour at most. Let's say you do this once or twice a week (ideally more).

At this point we know the lay of the land. If the maximum load on our layout is when we have guest operators over, we only need enough capacity for, at most, a three-hour session.

Design to operate

Now we get to the design part. The key question is this: how much layout does it take to create a three-operating-hour session? How many industries, or to be more accurate, how many car spots do we need? This is where people get into trouble. It takes far less layout than you would think because the individual operational tasks take far longer than you'd think.

Eight industries will give you a three-hour session. Certainly there will be some variation in this number depending on the type of industry but this is a good starting point. It certainly isn't 15 or 20 (or 50).

If you have the space, it doesn't hurt to put in a few extra to allow for some variety from session to session. A dozen industries would give you enough cushion so each session wouldn't be identical. I don't view this as being critical, though, because in the real world there IS a fair amount of repetition from week to week. The larger, more active customers are often switched every session. Remember also that the full-blown three-hour session is the exception, not the rule.

Of those eight basic industries I'd shoot for:

- One or two industries that have three or more car spots each
- Four or five that have just one or two car spots
- A couple of team track locations for unloading into the street or a parking lot

This is just a guide though. A basic two-track corn syrup facility could take two or three hours by itself to be switched, and one complex industry is a good design solution if you don't room for eight industries. (See "A modern industry for a compact space" by Jim Lincoln, in Kalmbach's "Model Railroad Planning 2010")

If your design starts running to more than a dozen industries, you may be designing in and building in more capacity than you can utilize.

There may be other reasons beyond operational variety for having a larger layout but you have to start asking yourself some very pointed questions as to what you are accomplishing with that extra capacity and square footage.

3: Shown here is the switch list of the eight industries worked in the three-hour session.

CSX		3 hour session			
Work Order					
Train:	Y120-03		KEY		
Date:	11/3/2007		WI: Work Instruction		
Set to Depart:	0800		PU: Pull industry		
Locomotive:	CSX 2771		PL: Place at industry		
INDUSTRY WORK AT: FPT					
Seq	CAR				
Num	INIT	NUMBER	WI	Spot	Remarks
1	CSX	709062	PU		
2	CSX	708761	PU		
3	CSX	709068	PU		
4	CSX	709042	PU		
5	CSX	709034	PL		Re-spot from storage track
6	CSX	708756	PL		
7	CSX	709052	PL		
8	CSX	709036	PL		
INDUSTRY WORK AT: MIAMI IRON AND METAL					
Seq	CAR				
Num	INIT	NUMBER	WI	Spot	Remarks
	SATX	3697	PU		
	SATX	1025	PU		
	SATX	2039	PL		
	SATX	1587	PL		
INDUSTRY WORK AT: FAMILY AND SON					
Seq	CAR				
Num	INIT	NUMBER	WI	Spot	Remarks
	UTLX	641531	PU		
INDUSTRY WORK AT: MIAMI WASTE PAPER					
Seq	CAR				
Num	INIT	NUMBER	WI	Spot	Remarks
	BNSF	131211	PU		
INDUSTRY WORK AT: TRUJILLO AND SONS					
Seq	CAR				
Num	INIT	NUMBER	WI	Spot	Remarks
	CRLE	19298	PL		
	TBOX	660329	PU		
INDUSTRY WORK AT: GENARO PRODUCE					
Seq	CAR				
Num	INIT	NUMBER	WI	Spot	Remarks
	ARMA	765298	PU		
INDUSTRY WORK AT: A-1 FARMERS CHOICE					
Seq	CAR				
Num	INIT	NUMBER	WI	Spot	Remarks
	PRL	1067	PL		
INDUSTRY WORK AT: MIAMI PRODUCE MARKET					
Seq	CAR				
Num	INIT	NUMBER	WI	Spot	Remarks
	SOU	52724	PL		

How a session goes

Take a look at the notes on the layout diagram. The work at the two scrap yards was about as simple as it gets, swapping loads for empties. Even so, the first 55 minutes of the session were spent here. It took about 20 minutes to swap out a load for an empty at Trujillo and about 25 minutes working the two industries on the switchback (which required particularly slow speed running and the use of fuses for the grade crossings).

The rest of the time was spent on the remaining industries, running down the main, brake tests, and pausing to review the paperwork. Note that there were many industries that were NOT worked. The two scrap yards, Trujillo Foods, and Family & Son would be switched every session.

For you operators out there, give conscious thought to how often you will be operating alone, how often you will be operating with guests, and your desired session length for each situation. Armed with that information, design your car spot count towards those target time periods.

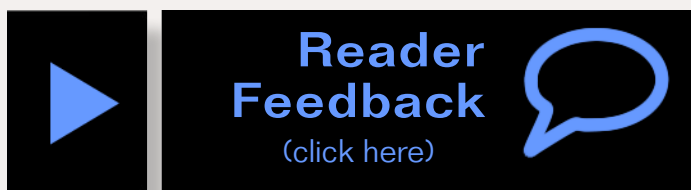

Lance Mindheim is the owner of The Shelf Layouts Company (shelflayouts.com), a designer and builder of custom model railroads. He has also published several books about model railroad design and construction, which are available from his website.



NORTH AMERICAN RAILCAR CORP
NORTH AMERICAN RAILCAR CORP



**New
4000 cf
Canadian
Built
Gondolas**



Available only in Canada,
you say? ... Pity, eh?

CLICK
FOR ...

HO Scale

CLICK
FOR ...

N Scale



Modeling a Coal Loader - Part 2



by Tom Patterson

Photos by the author unless
otherwise credited



Tom Patterson finishes the step-by-step construction of his backwoods coal loader ...

In part one, I described how to build the various pieces of this backwoods coal loader: the conveyor and supports, the break assembly, and the receiving bin. Part one also included a complete parts list.

Here in part 2, I add the truck receiving ramp, build the loader base, put a roof on the conveyor, add the short conveyor at the top of the larger conveyor, add corrugated siding and roof to the receiving bin, and install the loader on the layout.



STEP 10: The Receiving Ramp

For the ramp up to the receiving bin, I wanted something a little different than the typical earthen ramp with retaining walls on three sides that is common to so many truck dumps in the coal fields. The photo below was taken by Rob Wolshlager and shows Tipple 52 at the south end of Dante Yard on the Clinchfield Railroad.

The shape of the ramp, the wooden construction, and the overall appearance of this photo captured the look I wanted to create. You can see this photo and others of tipples and coal country structures on Rob Wolshlager's Clinchfield Country website at clinchfieldcountry.com.

I also referred to the pictures of the Dixie Mining truck dump tipple at Pikesville, Kentucky in Tony Koester's book *"The Railfan's Guide to Coal Railroading."*



30: Tipple 52 at Dante Yard on the Clinchfield Railroad.



contents



index

STEP 10: The Receiving Ramp *Continued ...*

I used scale pieces of basswood for construction of the ramp as I like the look of the wood when it's stained in appropriate colors. You could easily substitute styrene for this portion of the structure, and there are numerous techniques that can be used to make the plastic look very convincingly like wood.

If you're using basswood, it's imperative that you stain it before applying any glue. Otherwise, you will end up with areas where the glue dried that won't take the stain. For my stains, I used two basic colors: 1) a light grey made up of a 50:50 mix of Floquil Poly S Primer and water with a drop of liquid detergent added; and 2) a grimy black made from a 50:50 mix of Floquil Poly S Grimy Black and water with a drop of liquid detergent added.

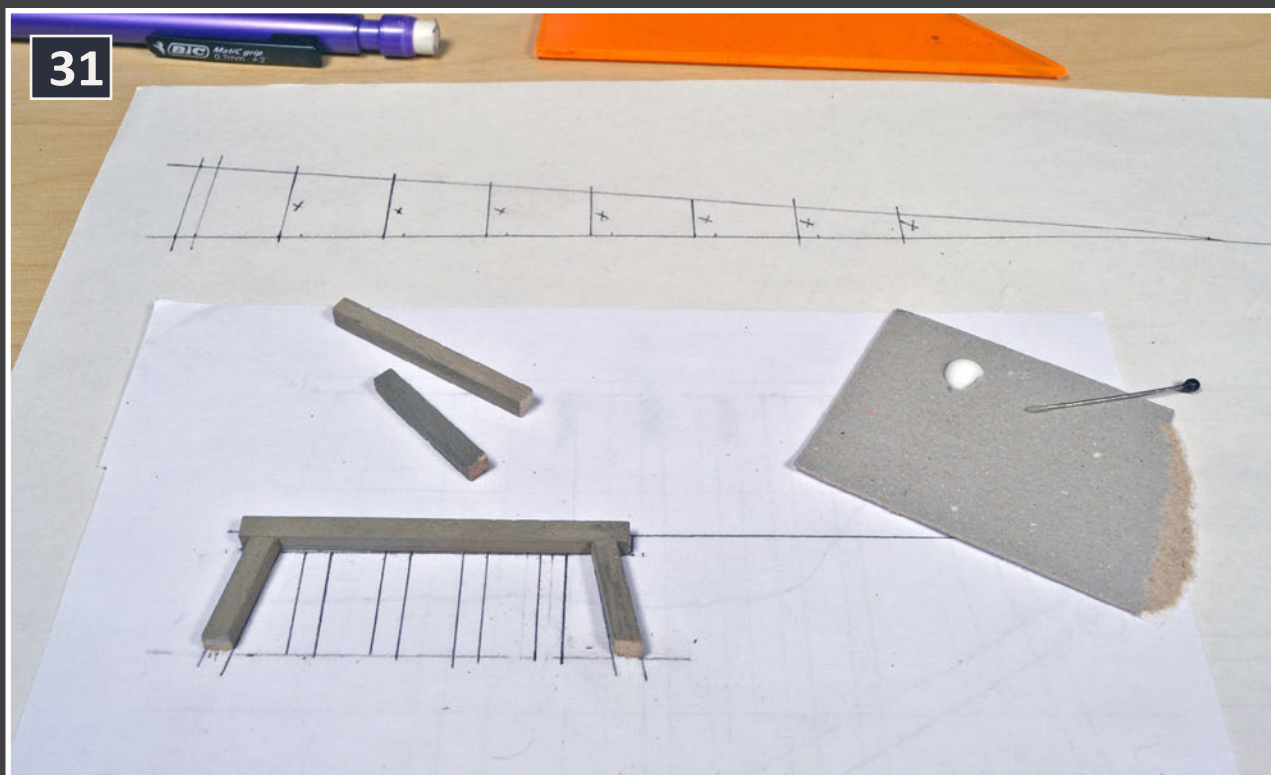

31: Basswood is used according to the drawing.

STEP 10: The Receiving Ramp *Continued ...*

Begin by staining a number of pieces of scale 12" x 12", 4" x 10", 2" x 6" and 4" x 4" with the light grey color. Once the light grey is dry, I put some of the black stain in a small container, dilute it little bit more with water, and then lightly brush it onto the wood pieces. The objective is to get a weathered grey color similar to that in the photo of Tipple 52.

Next, print the bent drawing shown in Drawing 5 and tape it to a flat surface. Use this template to construct all of the bents supporting the ramp. Cut pieces of the 12" x 12" to match the top timber and the posts using the template. The photo here (31) shows the bent template laid out along with the cap and the two end posts glued in place.

I use the small piece of cardboard and the pin in the photo (31) to apply small amounts of white glue to the ends of the posts. The photo (31) also shows the profile of the ramp that I drew in order to determine the height of the successive bents.



Tom Patterson got his start in model railroading with a Lionel train set at Christmas back in the '60s. That train set eventually became part of his first layout. Tom reentered model railroading in the late '70s and has been working on his current layout, the HO scale Chesapeake, Wheeling and Erie

Railroad, a free-lanced coal hauler set in West Virginia, for almost 20 years.

Tom and his wife have two grown children and live in Cincinnati, Ohio. They enjoy hiking, biking, reading and spending time with their family, which includes two rescue mutts and a large number of salt water fish.



contents



index

STEP 10: The Receiving Ramp *Continued ...*

Once the posts have dried on the first bent, cut two pieces of 2" x 6" to a length of 14' for the cross bracing. Glue them in place as shown in the photo above. Next, cut 7 floor joists from 4" x 12" basswood to a length of 50 scale feet. Make a mark 6" in from each end of the bent and glue a joist flush with this mark.

Glue the remaining joists in place spaced equidistant from the outer two joists. Cut a piece of 12" x 12" to a length of 15' and glue it in place by sliding it under the joists until it makes contact with the bottom of the joists at the end opposite of the bent.

The bottom of the joists at this end should remain in contact with the work surface. The photo here (32) shows how the ramp should appear at this point.

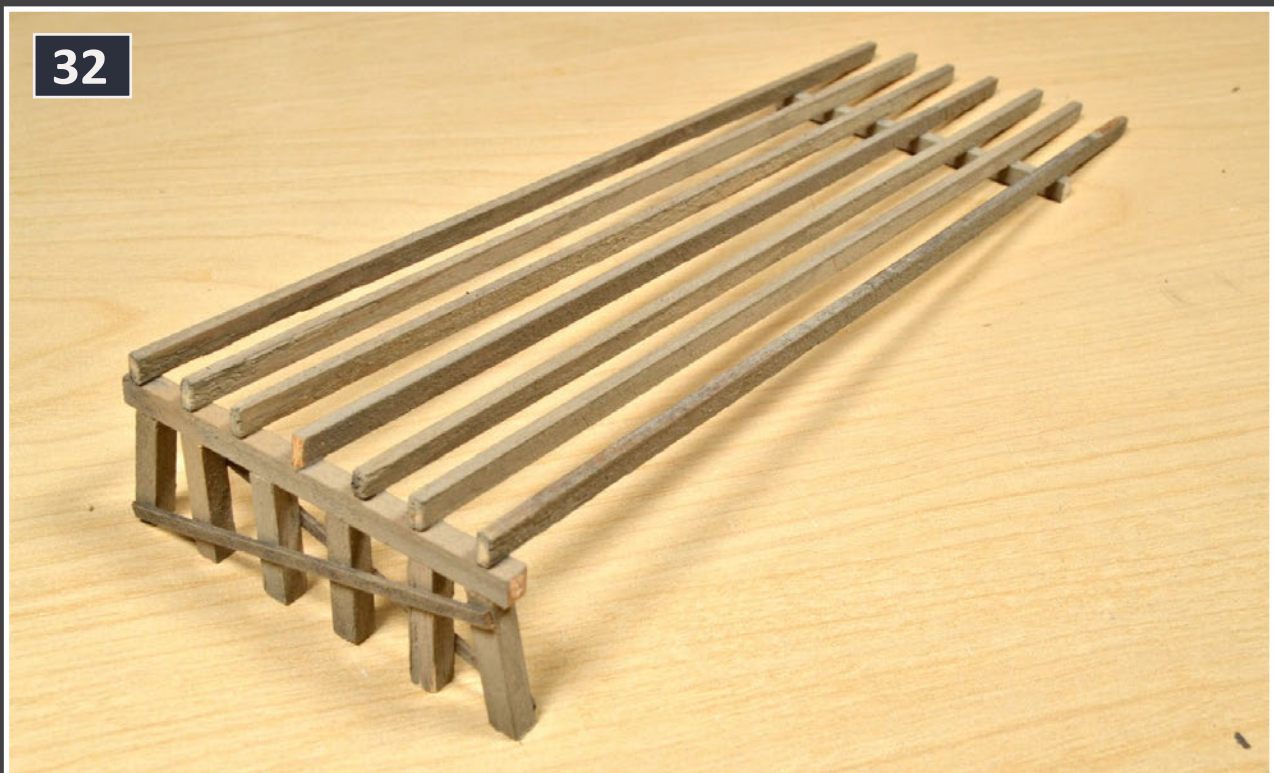

32: Keep the bottom of the joists on the table.

STEP 10: The Receiving Ramp *Continued ...*

The remaining bents are spaced 5' apart as shown on the profile drawing shown in Drawing 6.

Measure the height of the next bent, make a horizontal line at this height across the bottom of the bent template, and cut the cap and posts to fit. The cap should be the same 15' width for each of the bents. Follow this procedure for the next 3 bents and apply cross bracing using 2' x 6' pieces as outlined above. The cross bracing is omitted on the next five bents.

The support between the single piece of 12" x 12" and the last bent is two pieces of 12" x 12" glued together and sanded to fit under the joists. Next, cut the flooring from 4" x 10" basswood.



33

33: Installing the flooring on the ramp.



contents



index

STEP 10: The Receiving Ramp *Continued ...*

I used a Northwest Shortline Chopper for the various pieces of scale lumber and set the stopper at a distance of 14 3/4' from the blade. I varied the length of the floor boards by cutting various pieces slightly shorter than 14 3/4'. The first board at the top should be cut equal to the distance between the joists. This piece will be placed over the top of the bent, and we need to leave room to glue the railing posts.

The floor pieces at each of the bent tops should be cut in a similar fashion. The photo here (33) shows the flooring being installed. Note the floor boards at the tops of the first three bents- each has been cut flush with the edge of the floor joists as described above (33).

Installing the railings will finish the ramp part of the project. For the posts, cut 20 pieces of 4" x 6" to a length of 5 1/2' and glue them to the top of each bent. The lower railing is a piece of 2" x 6" and the upper railing is a piece of 2" x 4". Cut both pieces slightly longer than the distance between the posts at each end and glue them in place.

Photo 34 shows the completed ramp with the railings in place. Don't forget to touch up the unstained ends of the basswood. I used the same black stain used earlier but diluted it about 50/50 stain to water. I used a small brush and lightly touched each end in order to avoid getting too much stain around the ends of the pieces.

STEP 10: The Receiving Ramp *Continued ...*

I also stippled on some of this stain in the center of the ramp to represent oil and grease from the constant stream of dump trucks backing up to unload coal. We'll add some additional weathering later.



34: The finished ramp with the railings installed.



contents



index

STEP 11: Preparing the Assembly Base

At this point in the project, I thought the next step would be to construct the roofs for the breaker and the conveyor and put together the sides and roof for the receiving bin. As I began to take measurements for the roof of the large conveyor, I realized the part of the roof would extend over the tower at the end of the conveyor. And the end support for the roof would be attached to the tower.

Therefore, there was no way to accurately measure the length of the roof without having the conveyor and the tower glued in place. So the next step became building the base so that the breaker, conveyor and tower could be glued in place prior to constructing the roofs.

In order to make sure that all of the various pieces fit together correctly and to provide some support, cut a 13" x



35: Styrene base for large conveyor, breaker and receiving bin.

STEP 11: Preparing the Assembly Base *Continued ...*

5" piece of .060 styrene for the base. Position the receiving bin, breaker, conveyor and conveyor tower on the base and then mark the areas outside of the basic structure. Cut these away and you'll have a base that looks like the one in the photo above.

I realized at this point that I would need to add the ground cover under the breaker and the receiving bin prior to gluing them to the base. And before I could add the ground cover, I needed to install some base supports for the breaker and the large conveyor. In the photo here (35), the breaker is resting on two lengths of .040 x .040 styrene cut to the width of the structure and glued to the base at either end.

In order to elevate the large conveyor so that it would rest inside the breaker, I cut a piece of hydrocal from a retaining wall that I had left over from another project and glued it in place with epoxy. As a result of raising the end of the large conveyor at the breaker, the support bents for the conveyor were now too short.

I added a piece of .060 styrene to the styrene base along the length of the conveyor as shown in the photo here (35) in order to solve this problem.



contents



index

STEP 11: Preparing the Assembly Base *Continued ...*

Prior to applying the ground cover, I painted the area with PollyScale Grimy Black. For the ground cover, I used Highball Products N-Scale black ballast followed by coal dust and some Highball Egg Coal (3" - 5"). I soaked the area with 70% isopropyl alcohol and then applied a 2:1 mix of wet water (1 teaspoon of detergent to 16 ounces of water) and white glue.

Note in the photo here (36) that I kept the ground cover away from the areas where the legs for the receiving bin will be glued to the base. I also covered the work surface with a piece of wax paper to protect it from the glue and water.

Once the ground cover is dry, glue the breaker in place on the two pieces of .040 x .040 styrene.

Next, set the tower in place and carefully place the large conveyor between the tower and the breaker. Be sure to leave



36: Applying the ground cover.

STEP 11: Preparing the Assembly Base *Continued ...*

enough room where the large conveyor meets the breaker for the roof of the large conveyor to extend in under the breaker roof. Once you are satisfied with the position of the conveyor and tower, glue the tower to the base.

At this point I placed a small strip of .060 styrene on top of the last two roof brackets at the conveyor end and let it extend over the tower- see the photo above. Be sure that the conveyor is placed in the right location, both on the tower and at the base. If it isn't, the measurement for the height of the end brackets will be incorrect.

For the end roof brackets, measure the distance from the edge of the tower to the bottom of the piece of .060 styrene and cut two pieces of 3/64" angle to this length. Glue them in place as shown in the photo. Cut a piece of scale 2 x 6 to the width between the two angles, glue it in place and paint the angles and cross brace with the rust color used previously.

Now that this last piece of the roof bracing is in place, we can measure the full length of the roof for the large conveyor.

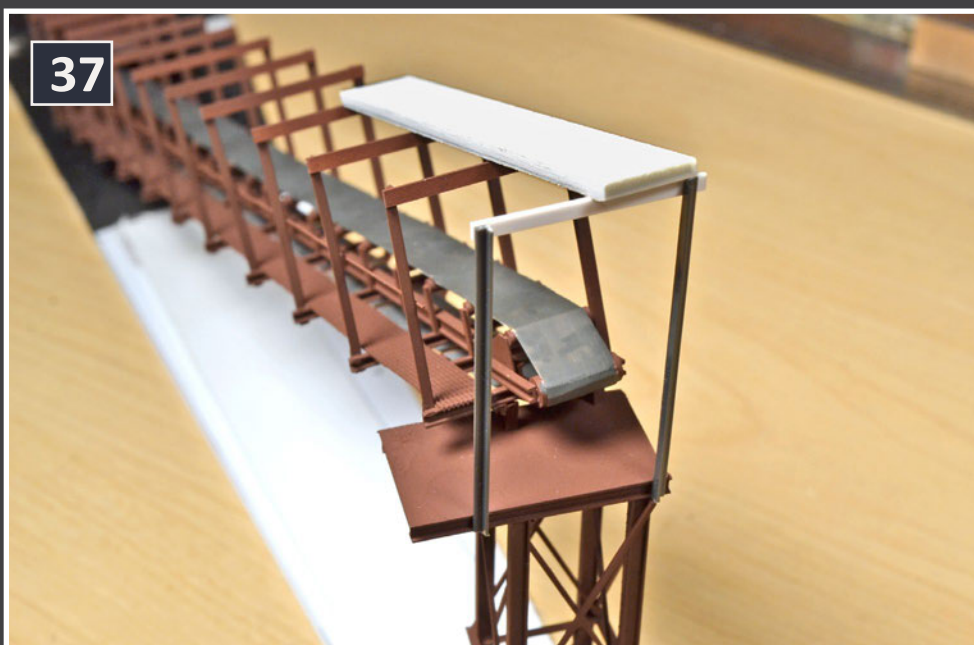

37: The conveyor and roof bracing.



contents



index

STEP 12: Conveyor Roof

For the roof of the conveyor, measure the distance from just beyond the edge of the roof bracket on the tower to the last roof bracket at the other end of the conveyor. Cut 4 pieces of scale 2" x 4" to this length. Glue two of the pieces together so that the 2" edge of one piece is flush with the 4" piece of another and repeat this with the second two pieces – see the photo here (38).

These two pieces will be the edges of the roof frame. Next, cut pieces of 2" x 4" to a scale 6'9" length and glue them to the long side of one of the roof edges at 3' intervals.

As you can see in the photo here (38), I made a jig for this step by taping a small block to my work surface and taping a piece of scale 2' x 6' away from the block. This allowed me to slide the 6'9" pieces under the roof edge piece until it hit the block,

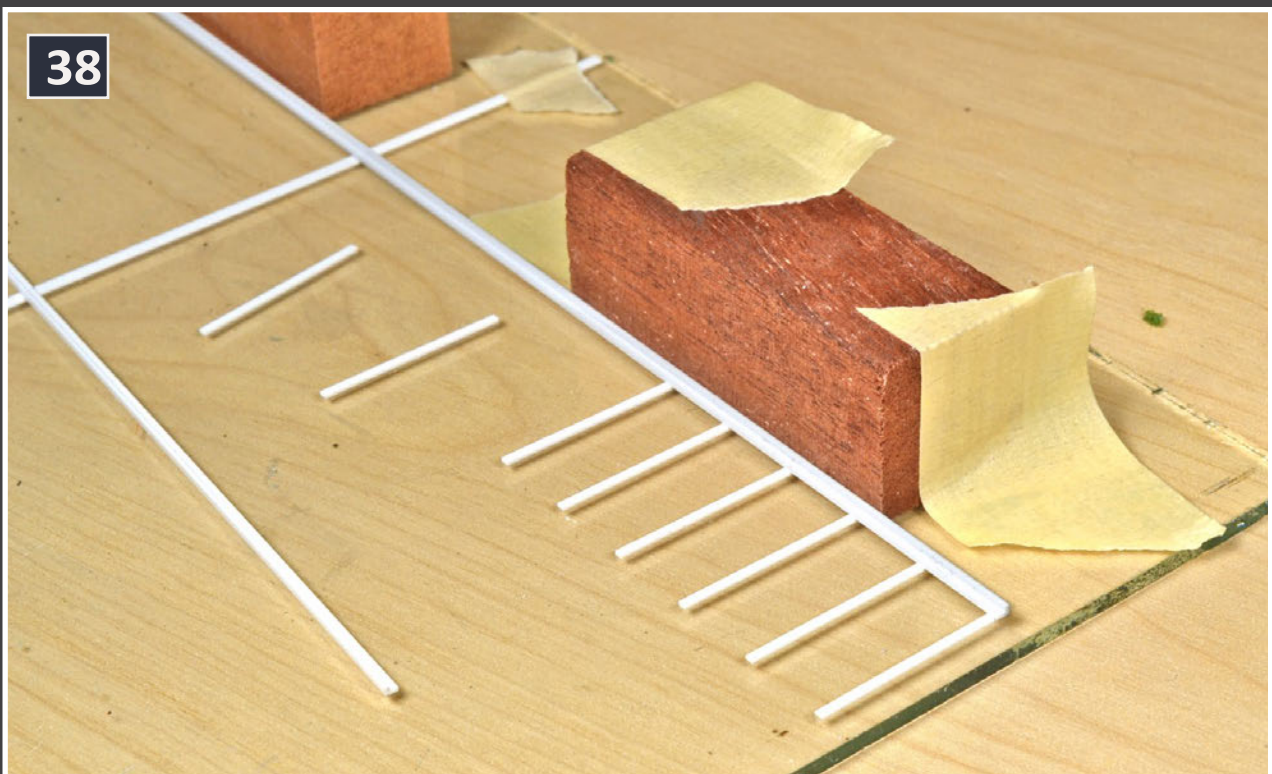

38: Building the conveyor roof.

STEP 12: Conveyor Roof *Continued* ...

insuring that it was flush with the edge of the roof edge piece.

Once all of the cross pieces are in place, glue the other roof edge piece flush with the cross pieces. Now cut a piece of scale 2' x 4' to the length of the conveyor and glue it in the center between the two roof edge pieces.

Once the roof for the large conveyor is complete, repeat the same steps for the roof of the breaker. Cut the roof edge pieces so that the roof of the breaker will extend slightly over the roof of the conveyor.

The photo here (39) shows the completed breaker roof and conveyor roof set in place. Next, paint both of these assemblies with the rust color used previously.

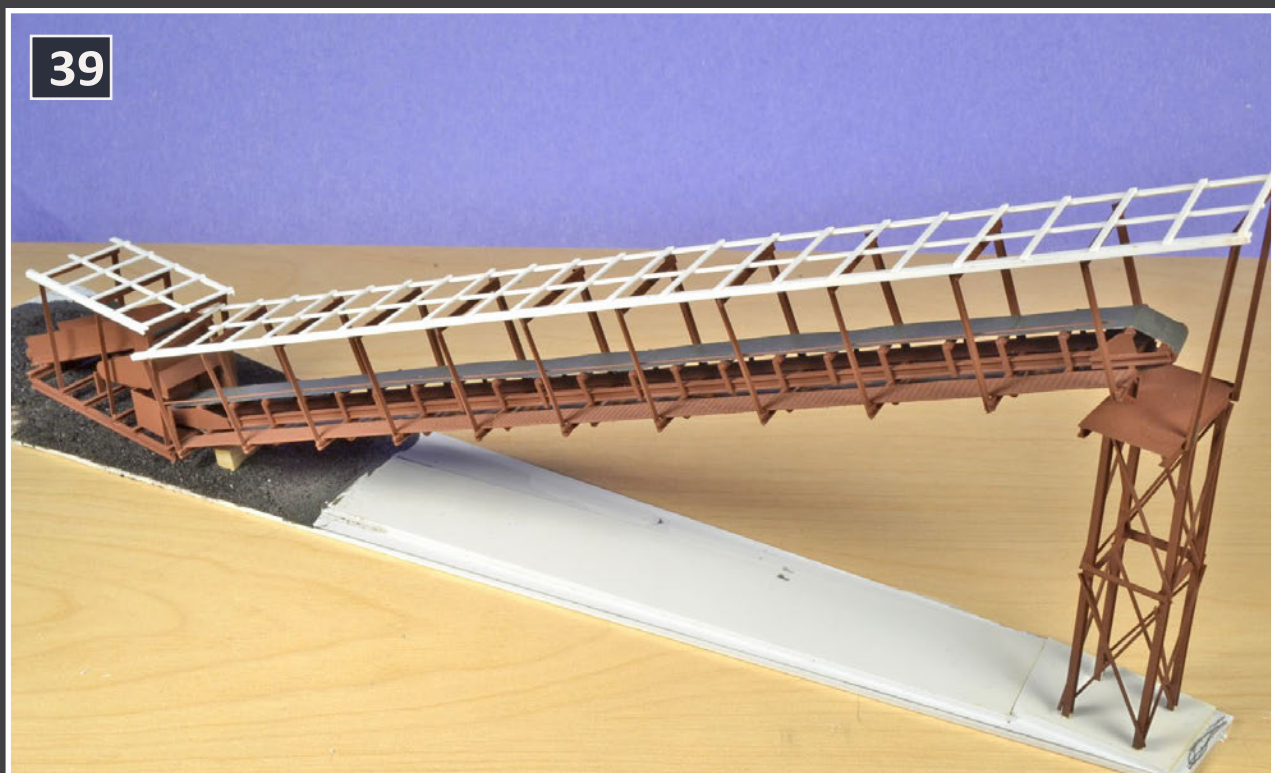

39: The completed breaker and conveyor roofs.



contents



index

STEP 13: Apply Corrugated Siding

I built the corrugated siding pieces for the roof and sides of the receiving bin and the roofs of the conveyor and breaker separately so that they could be painted and weathered prior to attaching them to the structure.

Also, given the somewhat fragile nature of the sub-assemblies, I didn't want to build these surfaces directly on the various structural elements. I used Campbell Scale Models corrugated siding for all of these pieces. While the Campbell product is some of the finest quality siding I have found in terms of detail and appearance, it can be difficult to work with.

The siding is very thin and easily damaged, so take your time when handling the product and follow the manufacturer's instructions when cutting individual pieces.

We'll start with the back wall for the receiving bin. I was concerned about trying to handle and paint the siding so I elected to use lengths of scale 1 x 4 to support the siding. These pieces will be hidden behind the cross bracing on the inside of the receiving bin.

Begin by cutting 2 pieces of 1 x 4 slightly longer than the width of the back of the receiving bin. Next, cut 4 pieces of 8' siding to a width of 4'. Measure the distance from the top of the side of the receiving bin to the top of the first cross brace. This should be approximately 1 3/4 scale feet.

Glue the first piece of 1 x 4 across the first piece of siding at this height. Now measure the distance from the top of the bottom cross brace on the receiving bin to the top of the top brace. Glue the second piece of 1x 4 to the first piece of siding at this distance from the top of the first piece of 1 x 4.

STEP 13: Apply Corrugated Siding *Continued ...*

Finish the side by gluing the remaining pieces of siding to the 1 x 4. You will need to cut the last piece of siding to fit as it won't be a full 4' in width. Also, be sure to overlap each siding piece.

The photo here (40) shows the completed siding for the back of the receiving bin. Note the small notches at the top corners- these are necessary to accommodate the channel for the roof.

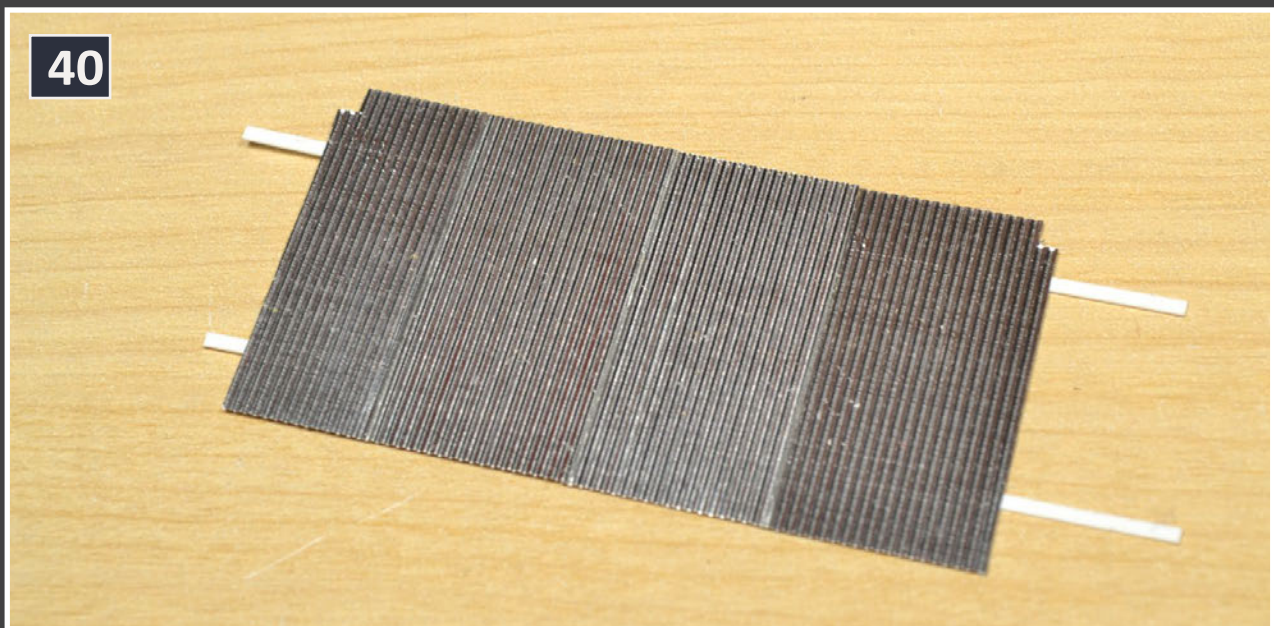

40: Completed section of siding with styrene cross member supports.



contents



index

STEP 13: Apply Corrugated Siding *Continued ...*

The corrugated siding pieces for the sides of the receiving bin are constructed in the same manner as the end piece with one exception.

The 2 x 4 braces are cut several scale feet shorter than the width of the side. This allows the very end of the side next to the end piece to bent slightly inward to cover the edge of the 2 x4's on the end piece of siding. Also, I measured each side and cut out a piece of paper to use as a template.

Begin by cutting a strip of corrugated siding to a height of 7 1/2'. Next, cut four 8' pieces from the strip and glue them to the pieces of 2 x 4. Make sure that the 2 x 4's are space in the same manner as the previous step. Cut 4 more pieces of corrugated siding and glue these to first row. Overlap the top of the first approximately 1 scale foot.

Take your template, place it on the siding and then using a straight edge, cut the roof angle on the siding piece. Photo 41 shows the inside of the completed siding piece. Repeat these steps for the opposite side. Take your template, place it on

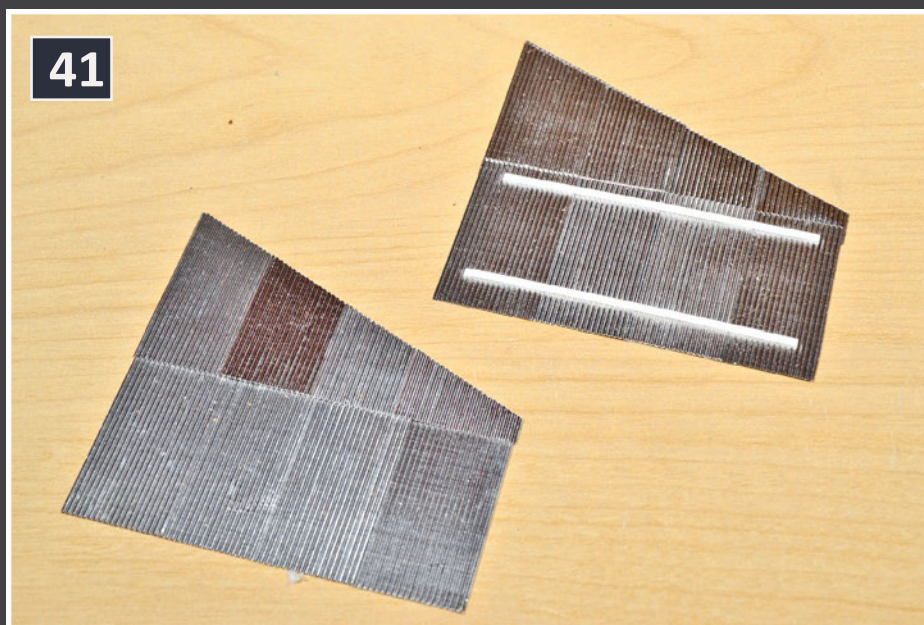

41: The corrugated sides of the receiving bin.

STEP 13: Apply Corrugated Siding *Continued ...*

For the roof of the receiving bin, cut pieces of corrugated siding to a scale 4' x 8' dimension. Begin at the bottom and glue the siding pieces together using ACC. I used a slow cure ACC so that I could make sure each piece was positioned correctly before the glue set.

The width of the roof should be just slightly wider than the 2' x 6' roof trusses. Therefore, the last piece in the first row will have to be trimmed a bit to get the correct width. Start the second row from the opposite end of the first row so that pieces overlap in the opposite direction. The pieces for the third row will need to be cut shorter than 8' in order to have a slight overhang on the front and back sides of the roof.

The roofs for the breaker and the large conveyor are next. Begin with the breaker roof and cut two pieces of 4' x 8' pieces of corrugated aluminum. Glue the pieces length wise so that there is a 1' overlap. Cut 2 more pieces of siding to a width of 4' and a length that will give you a slight overhang at the end of the breaker next to the conveyor and glue these to the first two pieces.

The end of the roof next to receiving bin will be flush with the support bracket. For the large conveyor roof, cut a number of pieces of siding to 4' x 8' dimension. Glue the first 2 pieces together with a 1' overlap. Glue the next 2 pieces so that they overlap from the opposite side.

Overlap the ends by 1 scale foot. This will provide some additional strength to this sub-assembly. The photo here (42) shows the completed roofs for the receiving bin, breaker and large conveyor.

At this point I spray painted all of the siding and roof pieces with Floquil Old Silver. Gently tape the pieces to a flat piece of wood with drafting tape, which is a lot less sticky than regular



contents



index

STEP 13: Apply Corrugated Siding *Continued ...*

masking tape. Once the first side of each piece is dry, flip them over and paint the other side.

Once the paint had cured, apply a spray of Testor's Dullcote to each side. The last step is to weather each piece on both sides using your favorite weathering techniques. For this step I used artist's oils and paint thinner, applying the colors in washes.

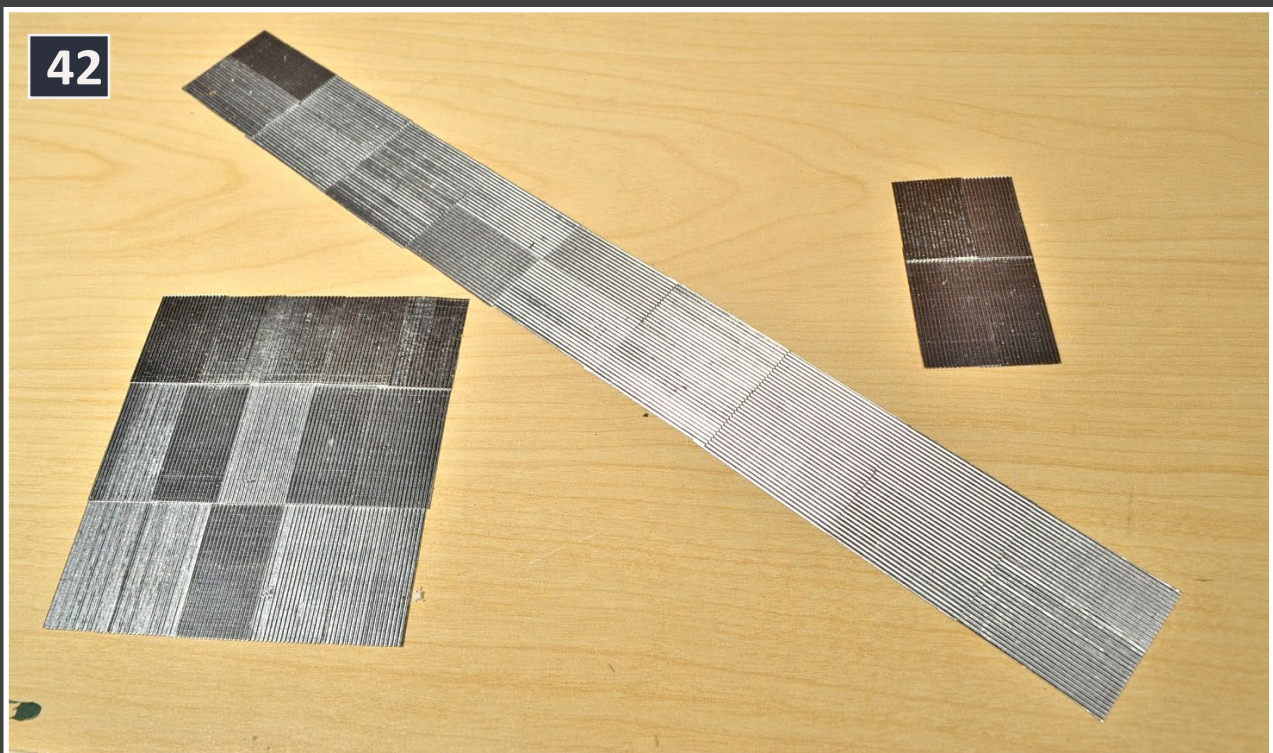

42: The completed roofs for the receiving bin, breaker and large conveyor prior to painting.

STEP 14: Final Assembly *Continued ...*

To build the small conveyor that sits at the top of the tower, start by cutting two pieces of 3/64" channel to a length of 10 scale feet. For the rollers, cut two 2' pieces of 1/8" styrene tube. Glue the first piece to the end of one of the pieces of channel and glue the second one 2 1/2' in from the other end- see the photo above for the location of the various pieces.

Next, glue the other piece of channel to the other side of the pieces of 1/8" tube. The rollers should be centered on the channel pieces. For the platform for the motor, cut a piece of .010 sheet styrene to the width between the channels and a length of 1 3/4 scale feet and glue it the end of the channels away from the rollers (described on next page).

The electric motor (see 43a) is from Williams Brothers but you could substitute something similar from your scrap

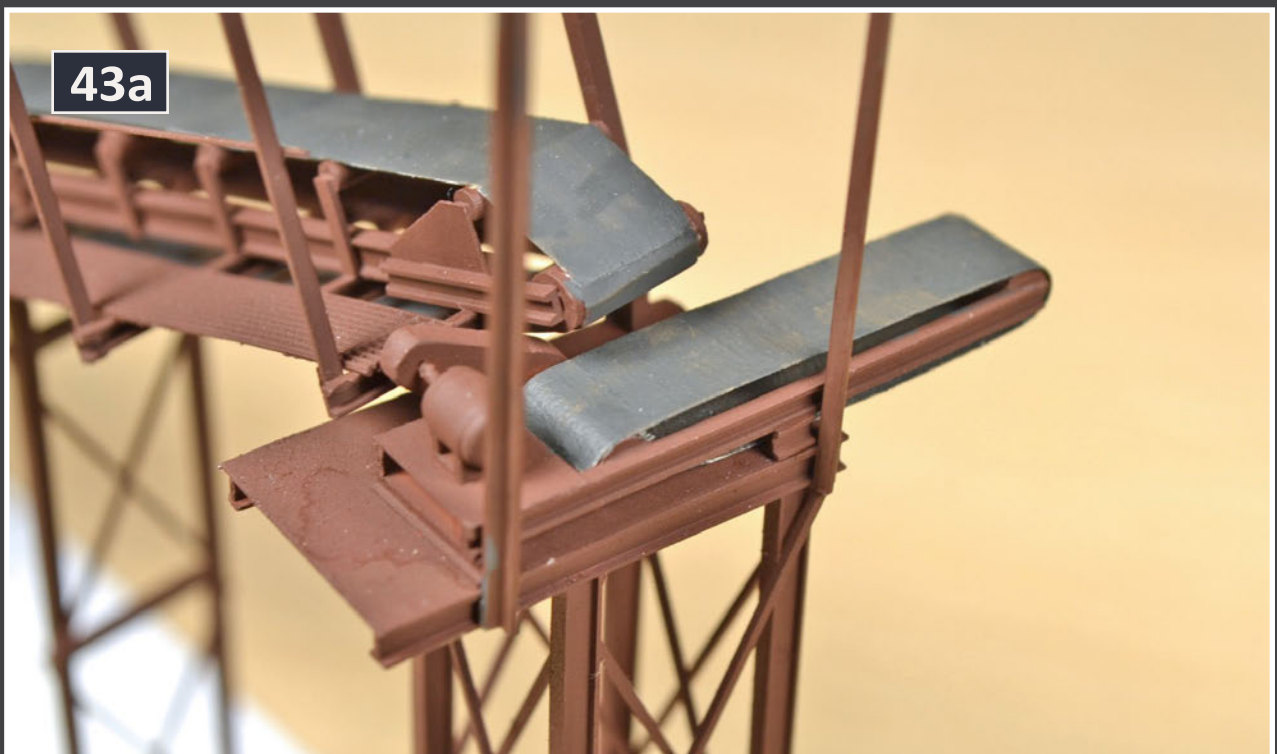

43a: Mounting the conveyor bents.



contents



index

STEP 14: Final Assembly *Continued ...*

box. The belt cover is a piece of .060 styrene filed and sanded to shape. Next, cut a piece of .060 I-beam to the width between the channels and glue it at the end of the channels under the platform.

Cut two small pieces of .060 I-beam and glue them parallel to the bottoms of each channel approximately 3' from the end of the conveyor away from the motor.

Paint this assembly with the same rust color used previously. When the paint is dry, make the belt from a strip of masking tape and paint it a grimy black color.

Photos 43a and 43b show the small conveyor in position at the top end of the tower.

43b

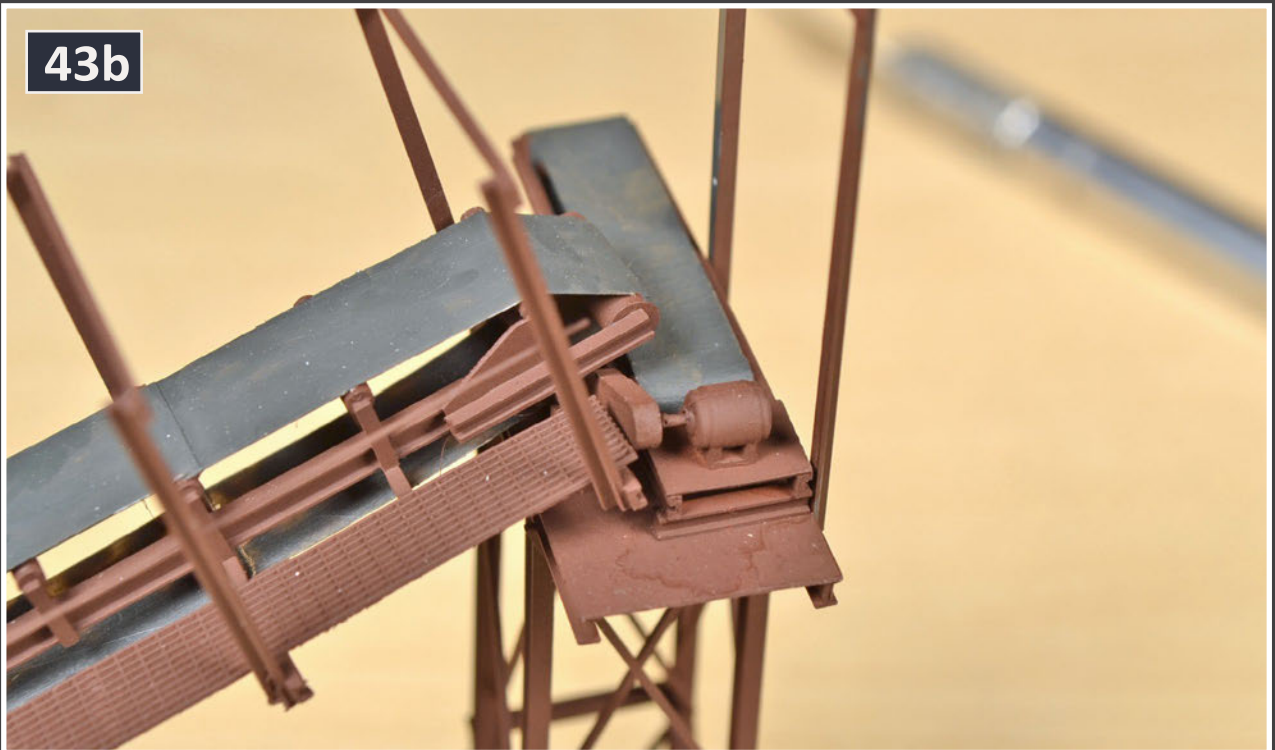

43b: Another view of the small conveyor in position.

STEP 14: Final Assembly

Prior to installing the siding and roofs, we'll finish up construction of the conveyor. Set the large conveyor in place between the breaker and the tower. Now position the small conveyor so that the belt from the large conveyor extends slightly over the top of the belt on the small conveyor.

Glue the small conveyor in place and then glue the large conveyor in place by brushing a small amount of liquid cement between the I-beam supports and the bottom rails of the large conveyor. Next, glue the 4 bents in place.

As you can see from the photo below, I had to shim 3 of the support bents in order to get them in the right position. Use small scraps of styrene for the shims.

Note that the receiving bin has not been glued in place yet—we need to apply the siding to the back before this step. Once the bents are in place, paint the surrounding styrene a grimy black color.



43: The final construction, and painting.



contents



index

STEP 14: Final Assembly *Continued ...*

To complete the construction of the structure, begin by gluing the frames for the conveyor roofs to the corrugated siding roof pieces. I used two part epoxy and applied it sparingly to the top cross pieces, placing glue on every 4th or 5th cross piece.

Repeat this step for the frame and roof for the breaker. Because the roof of the large conveyor extends into the frame of the breaker, trim the corner of the roof so it will slide in past the roof support on the left side of the breaker. Test fit both pieces, make any adjustments that are needed and then glue them in place by applying two-part epoxy very sparingly to the top cross braces on the conveyor.

I placed several small wood blocks on the roof of the large conveyor as shown in the photo here (45) in order to make sure it sat down on the roof braces.

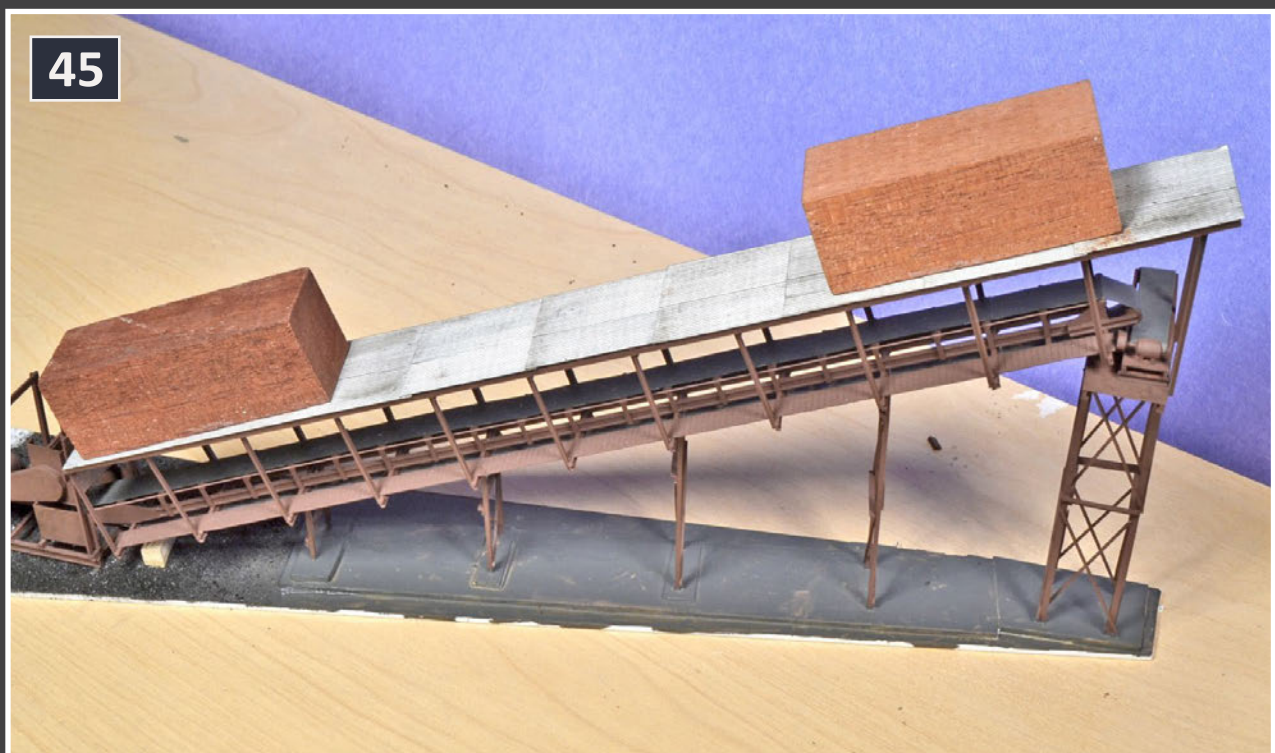

45: Wood blocks weight down the assembly.

STEP 14: Final Assembly *Continued ...*

For the receiving bin, trim the styrene cross-braces on the end piece of siding flush with the sides. Place a small amount of two-part epoxy on the cross-braces and glue the siding in place as shown in the photo here (46).

Next, glue the side pieces in place in the same manner as the end piece. I placed two small wood blocks on the ends of the sides in order to make sure that the siding was in contact with the vertical supports.

Once the sides are finished, glue the roof in place.



46: The receiving bin.



contents



index

STEP 14: Final Assembly *Continued ...*

Photos 47 through 50 show the conveyer, the breaker and the receiving bin with all of the corrugated siding in place.

Now glue the receiving bin to the base, paint the area around the legs with grimy black paint and add scenery material around the legs as was done in Step 11.



47: Conveyor roof with siding view 1.

STEP 14: Final Assembly *Continued ...*

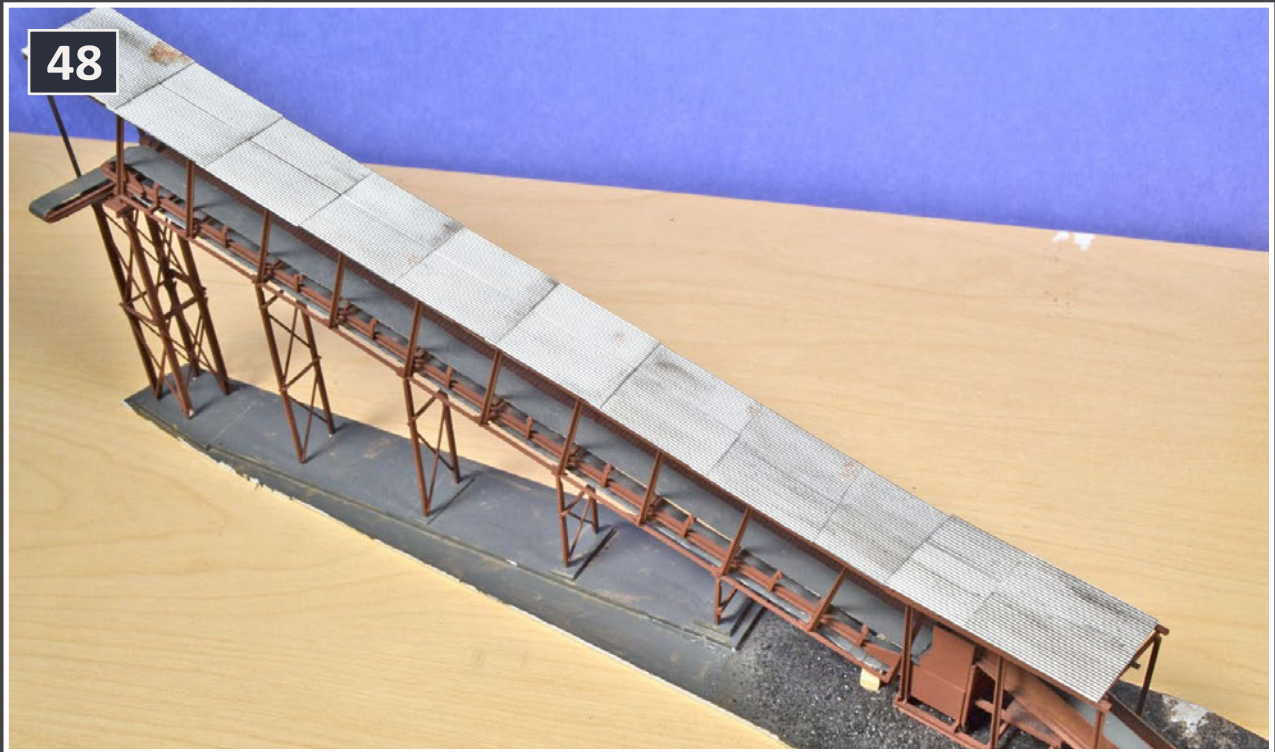

48: Conveyor roof with siding view 2.



46-47: The receiving bin with siding.



contents



index

STEP 15: Finish the Layout Site

At this point the construction of the tipple is complete, with the exception of some final weathering, and it is time to focus on the area on the layout where the structure will be located.



51: Preparing the area of the layout for installation.

It's important to get a flat, level surface to serve as the base for the structure. I applied Red Devil Onetime lightweight spackling on top of the hard shell scenery and then leveled it with a stick that I slid along two parallel tracks – see photo 51.

As I wanted the surface to be slightly below the level of the rail, I glued a piece of wood that was slightly shorter than the distance between the tracks to a piece that spanned the distance. The shorter piece was glued so it was slightly lower than the bottom of the longer piece.

STEP 15: Finish the Layout Site *Continued ...*

Once the spackling dries, glue the structure in place using a small amount of white glue. I used white glue because I want to be able to remove the structure in the future without damaging it and the white glue provides just enough adhesion to hold the structure in place.

Next, use some of the spackling to build up an earthen ramp to the beginning of the wood ramp- see the photo here (52). I also built up the area where the trucks would pull in prior to backing up the ramp. Once the spackling dries, paint the surface with your basic ground cover color. I use a 50/50 mix of cheap, tan latex paint and water.



52: Building up the earthen ramp.



contents



index

STEP 15: Finish the Layout Site *Continued ...*

To begin the scenery work, start by applying a base layer of ground cover, dirt, gravel, and coal. For the basic ground cover, I use a mix of 3 parts Woodland Scenics Grass T45 and 2 parts Woodland Scenics Earth T42.

I use Highball Products #172- Dirt for the dirt and Highball Products N-scale black ballast for the initial layer of coal.



53a-b: Blending the ground in around the structure.

STEP 15: Finish the Layout Site *Continued ...*

The gravel is a 3:1 mix of Highball N-scale limestone ballast that's been sifted through an old stocking in order to get the finest particles possible and Highball Products dirt. Combining different shades of tile grout would achieve the same kind of appearance.

I like to build up my scenery in layers, and I start by working my way in from the edges by first sprinkling on the ground cover followed by some dirt and then the gravel. This creates a natural transition from the vegetation on the side of the road to the gravel.

For the coal around the tipple, I sprinkled on N-scale black ballast. Once I'm happy with the overall appearance, I wet the area with 70% isopropyl alcohol and then apply a 3:1 mix of wet water and white glue.

Once the base layer of scenery is dry, it's time to come back to apply the final layer. I wasn't happy with the initial layer of gravel, so I mixed three parts Highball Products N-scale limestone ballast with one part finely sifted play sand. I used real coal dust and coal around the tipple, and covered the other areas with various types of ground covers to get the final look.

Once everything was in place, I applied isopropyl alcohol and diluted white in the same manner as the previous step in order to hold everything in place.



contents



index

STEP 16: The Finished Scene

The photo here (54) shows the tipple in service on the railroad once the final layer of scenery material was applied.

This has been a fun and rewarding project, and I hope that you can use some of the construction techniques and ideas to build tipples and other structures on your layout.



54

54: The tipple in service on the railroad.

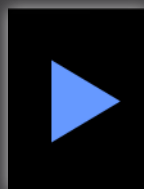

**Reader
Feedback**
(click here)



Box of Blocks

Over the years I have collected small pieces of wood from just about every project I've done that required some type of wood. At some point I started keeping a box of small pieces on my modeling table to use for a number of tasks, such as elevating the side of freight cars while applying decals, holding pieces of styrene in place while the glue dried, etc. I eventually wound up with another box on the workbench and this one contains slightly larger blocks.

I use these to assist in assembling structures, holding up backdrops for photographs, etc. And lastly, I have one in the layout room that contains a wide variety of shapes and sizes. I used these block for countless projects, from construction to mock-ups to temporary supports. These blocks are great, inexpensive tools that can assist you in a wide range of projects. ■



56: Scraps of wood that are very useful.



contents



index

Free Shipping on all US WEB orders over \$100.



New ACCU-LITES exclusive!



Tortoise SNAPS 8-position block wiring quick connect socket

Watch our website for our monthly specials!

CLICK TO LEARN MORE:

<http://www.acculites.com>



Structures of simple elegance ...

Made in the USA

ALPINE - DIVISION SCALE MODELS

Click to Learn more...

alpinemodels.com



contents



index

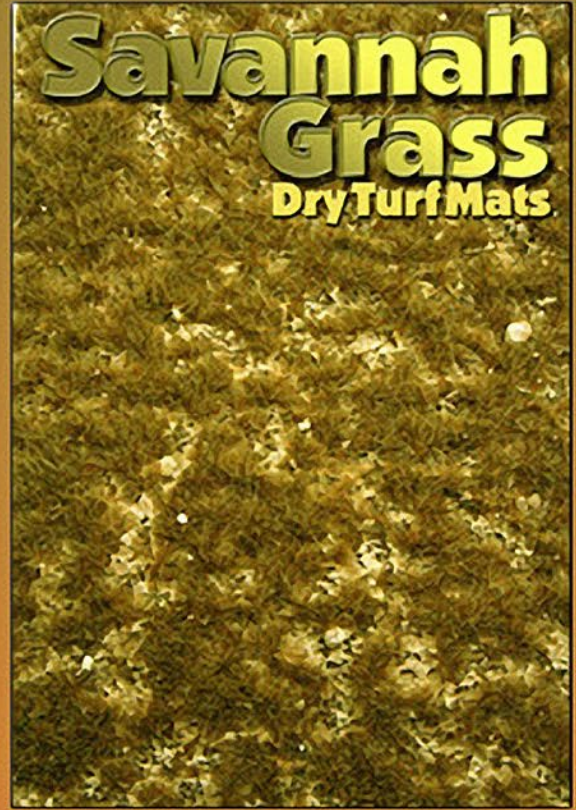
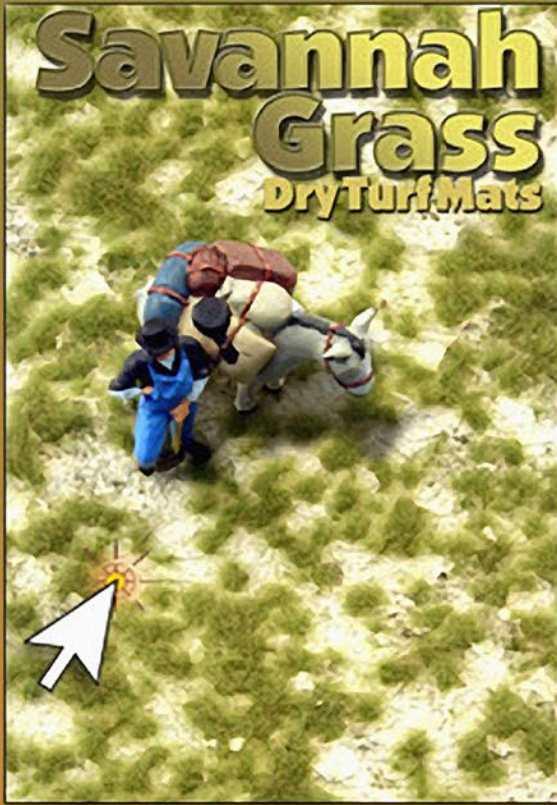

Click for more - lots more!

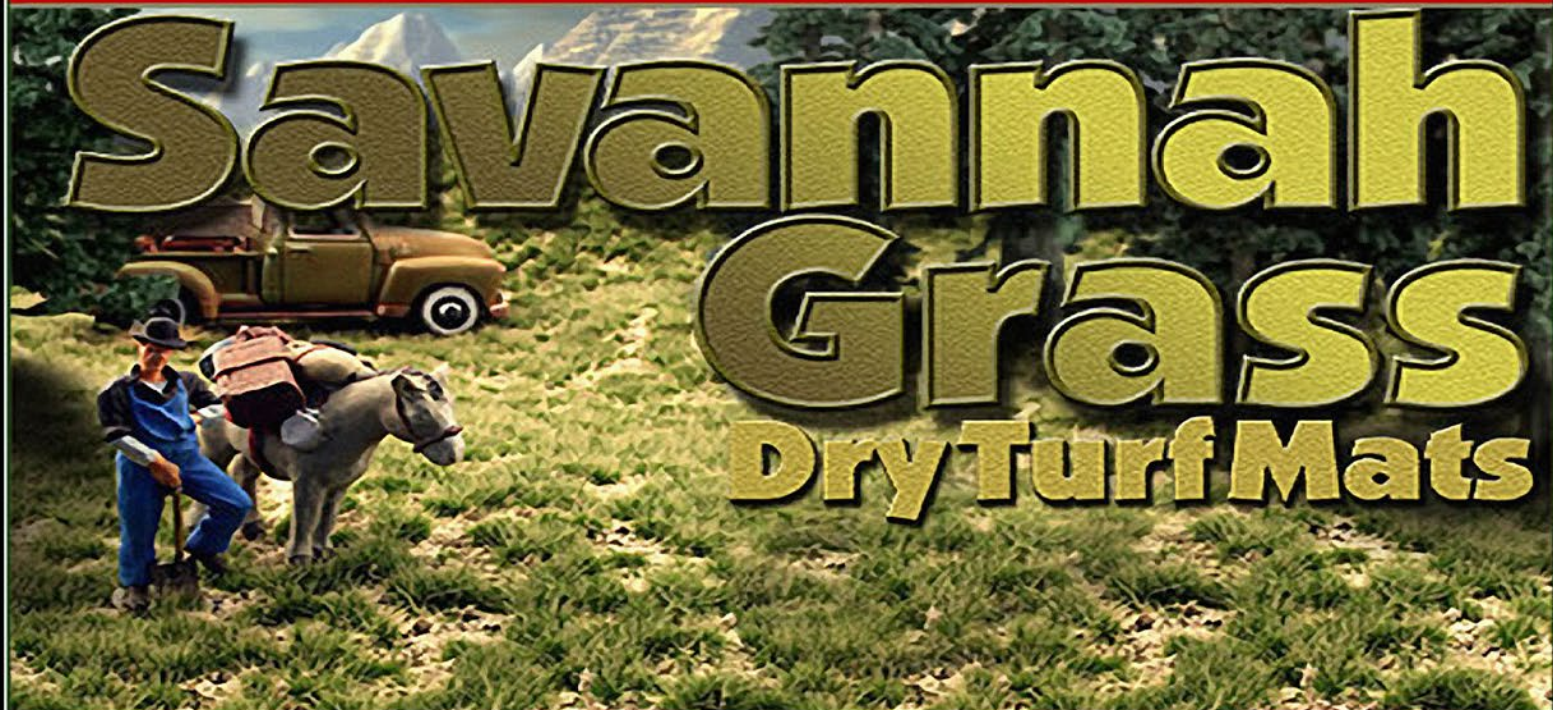

Email

Phone

contents

index

THE FORT WAYNE UNION RAILWAY

A starter layout you can build for under \$500

by Don Hanley

Grand Prize winner of the MRH \$500 Starter Layout design challenge contest



1

1: The Fort Wayne Union Railway modeled in the 1950s might look something like this diorama photo by Charlie Comstock.

Corporate History

The Fort Wayne Union Railway was incorporated October 11, 1922 and was owned by the Pennsylvania Railroad Co, The New York, Chicago, and St Louis Railroad Co. (NKP), Wabash Railway Co., and the New York Central Railroad Co.



Item	Unit Price	Qty	Extension
10" x 12 shelf bracket (1)	\$1.67	16	\$26.72
0.708" x 4' x 8' cabinet grade plywood (1)	\$27.97	1	\$27.97
1/4" Purebond maple plywood (1)	\$9.78	1	\$9.78
Atlas code 83 track 100 ft (2)	\$46.00	1	\$46.00
Mid West Cork 22 pieces (3)	\$22.50	1	\$22.50
P87 Stores fast & easy turnouts	\$9.95	10	\$99.50
MRC Prodigy Express (4)	\$99.79	1	\$99.79
Caboose Industries (5)	\$2.75	11	\$30.25
Miscellaneous wiring	\$25.00	1	\$25.00
Scenery materials (6)	\$75.00	1	\$75.00
		Total	\$462.51

Sources:

- 1 - HomeDepot
- 2 - eBay - includes shipping (user: dedgtr6izo)
- 3 - eBay - includes shipping (user: russeler100)
- 4 - eBay - includes shipping (user: salami kid)
- 5 - Walthers, on sale
- 6 - Allowance for purchase of scenery materials

Each railroad owned a quarter of the line. The Fort Wayne Union Railway was incorporated to provide for transfers between the controlling carriers and to make certain territory available for industrial development and to serve industries located, and to be located in and around Fort Wayne IN.

Each of the 4 owners of the FWURY operated the line for a period of 6 months during which each owner provided their own crews and motive power for their time period of operation. The FWURY made direct connections with the NKP, WAB, and PRR on the east side of Fort Wayne.



contents



index

Designing the layout

With this brief prototype history, I chose to proto-lance a small switching layout as my entry into the MRH design challenge. Given the limitations on money forces one to think about what you should spend the funds on and what to ignore. I view this layout as a section that can be further expanded in the future. I have also made the assumptions:

1. The modeler has had some previous experience as a youth building models or model railroading
2. The modeler has limited space available at the present time
3. The layout must be expandable in the future.

2 THE FORT WAYNE UNION RAILWAY Track Plan

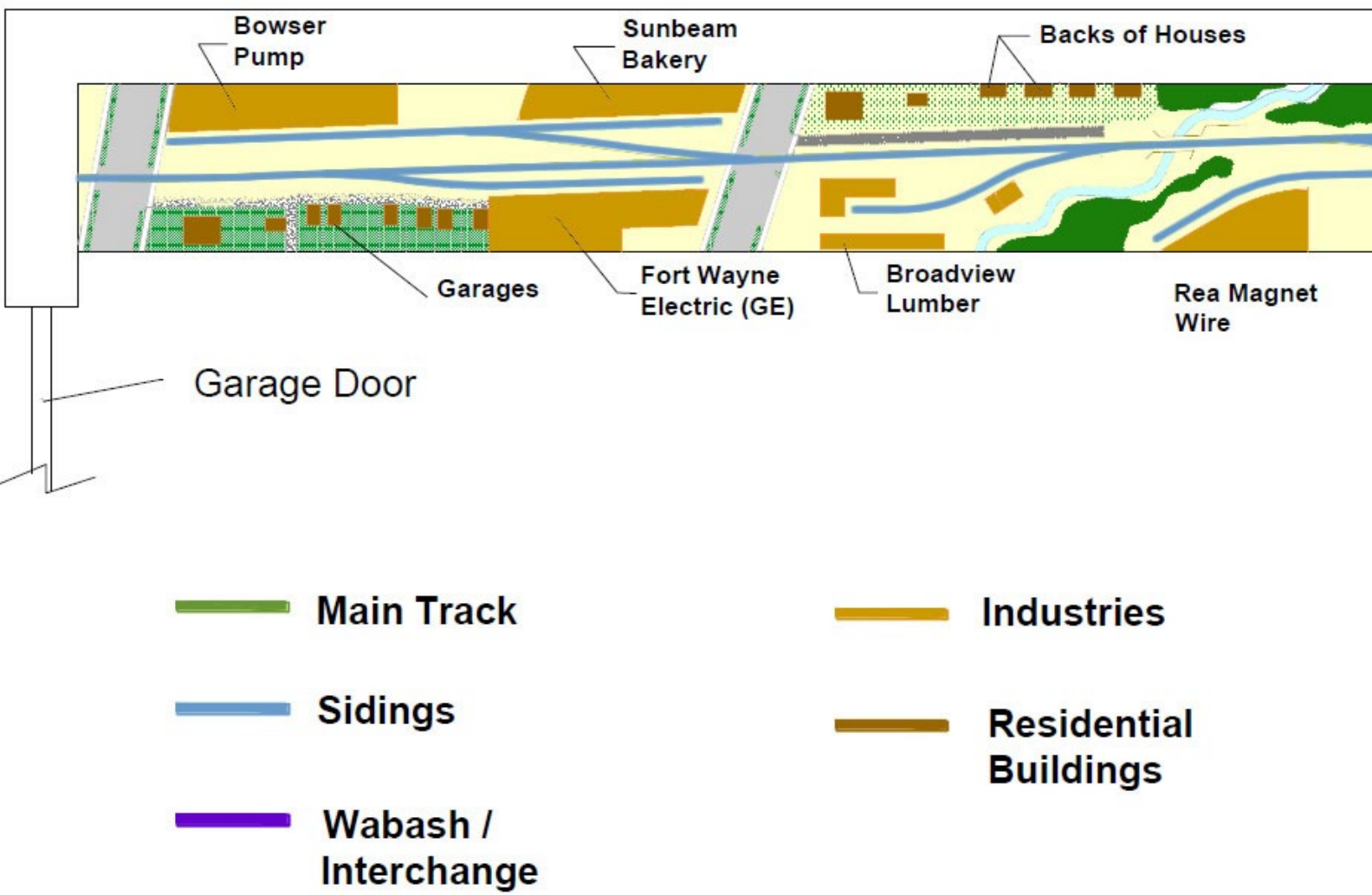

4. The layout can fit along one side of a garage.
5. The layout can serve as a base for developing ones skills on different aspects of modeling railroading.

I designed the layout to include an interchange with the Wabash RR, since on the prototype it was the only one with an overpass. On the prototype, the railroad ended at the NKP main a little north of the Wabash and at the PRR yard approximately 2 miles to the south.

I did not limit myself to the industries that are served by the line, but rather used different industries that were a part of the Fort Wayne industrial base beginning the 1940s. Motive power on this

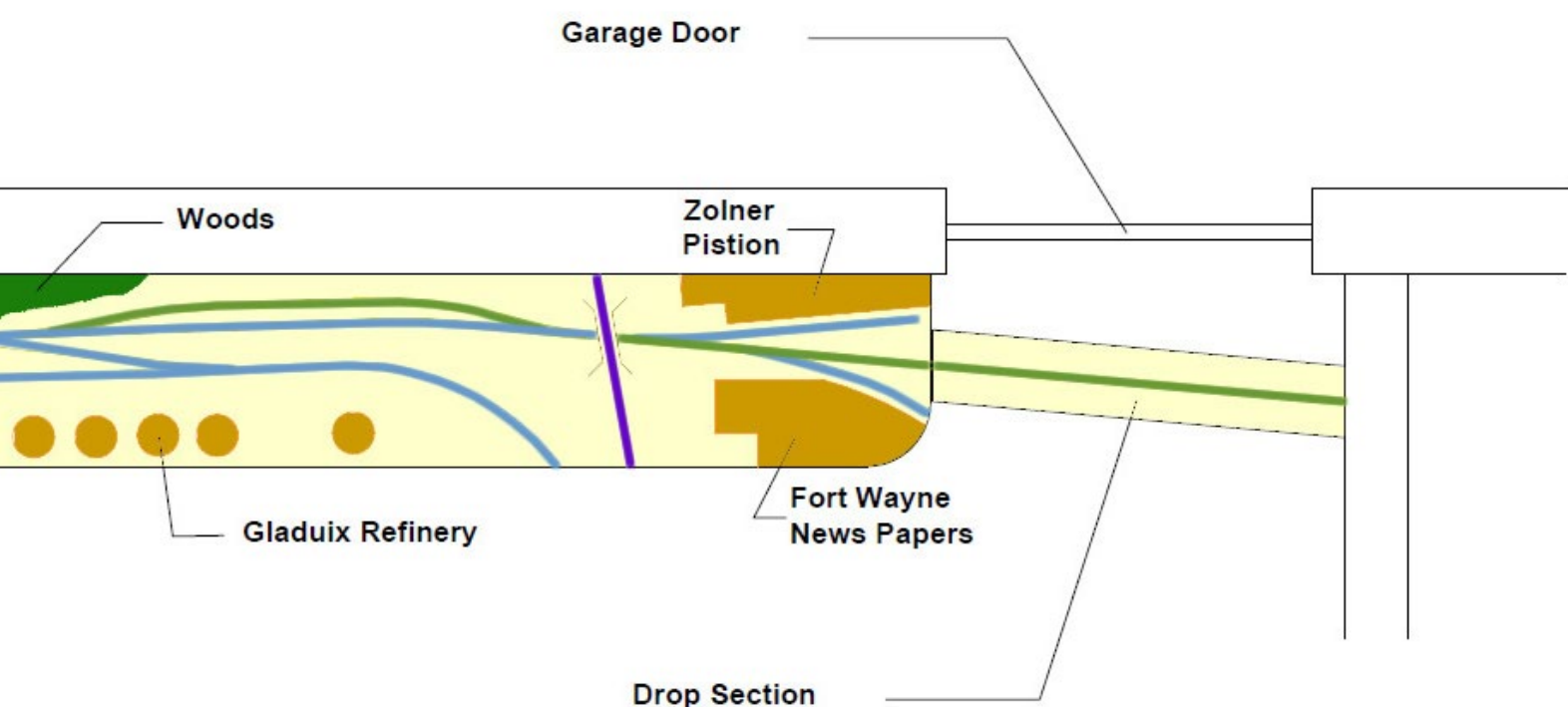

2: The Fort Wayne Union Railway track plan has 2 distinct switching areas that are separated by a small creek. The area to the right is strictly an industrial area, representing industries built during the WWII timeframe. The area to the left of the creek represents a mix of industrial and residential structures, typically built between WWI and the Depression era.



contents



index

layout can be anything from a 0-6-0 steam locomotive to a modern GP unit and anything in between.

I choose to use the creek and wooded area as a scenic divider on the track plan. The idea is to make the layout look larger by having a bit of extra run between the two groups of industries.

Operations

Operation is set up with a removable arrival / departure track at the right hand side of the layout.

The arriving train would bring cars from one of the other interchange roads (PRR or NKP) to service the local industries as well as interchange with the Wabash. Cars from the Wabash would be picked up and sent to the appropriate industries or be taken back to one of the interchange roads at the end of the operating session.

If the modeler chooses, at some point in the future, the Wabash could be extended with industries along it. This would give opportunity to have two switching operations and transfer cars between the two roads.

Layout construction

To reduce the cost of construction, I have designed the layout to rest on shelf brackets. The 10" x 12" brackets will need to be placed every 16" to align with the studs in the wall. The brackets will be placed with the 12" side up.

I choose to use 0.708" cabinet-grade plywood that is available from my local Home Depot. I have seen the local store make numerous cuts for customers at no cost. See the Plywood cutting diagram, figure 3. The fascia is from a piece of 2' x 4"

3 Plywood cutting diagram

— Cuts for sub roadbed
— Cuts for Stringers

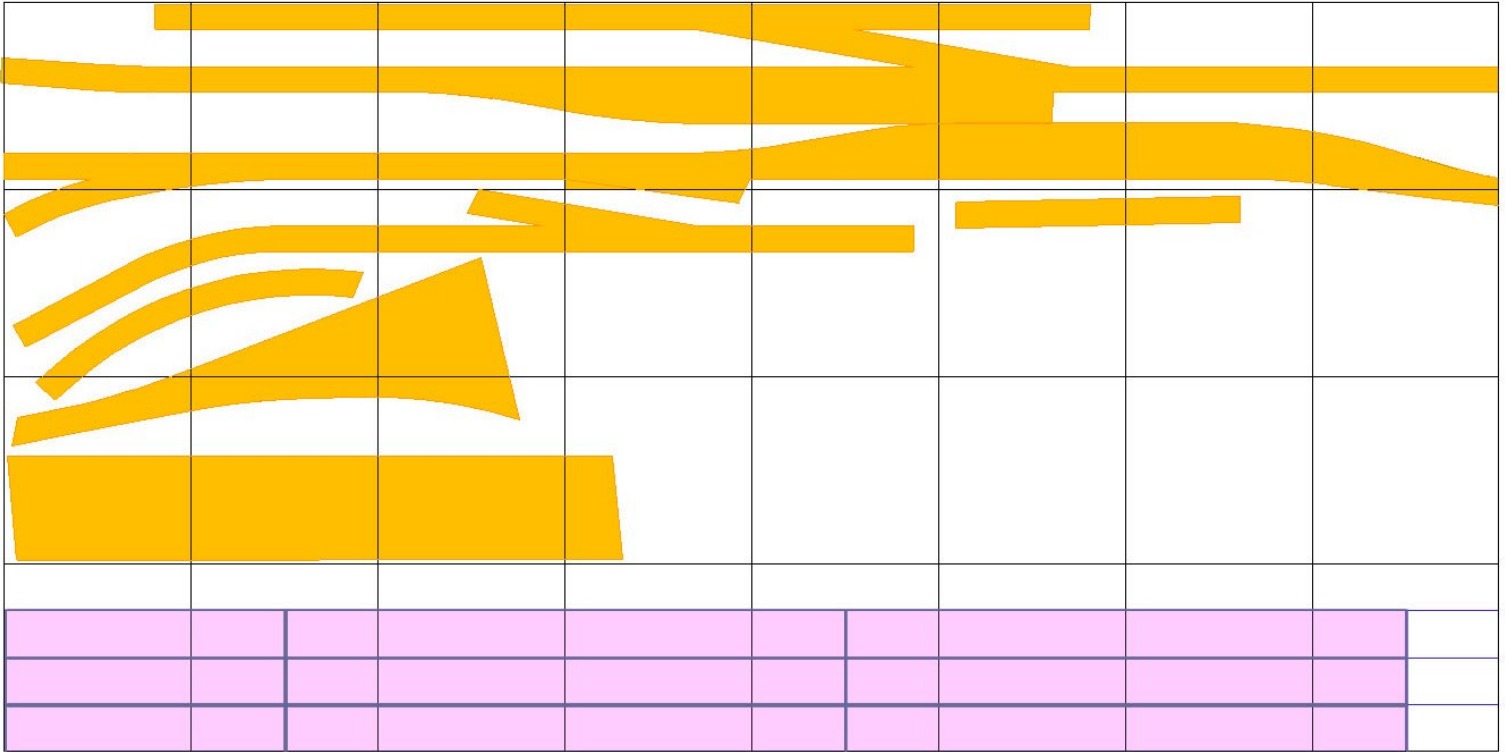

3: Plywood cutting diagram. See text.

hardboard cut into 6" strips This provides a total length of 24' which is more than enough for the 21'-6" needed for the fascia. The extra can be used in other areas.

Lay 1" x 3" strips of plywood across the shelf brackets to use as the mounting surface for the risers and a place to anchor the fascia. While the individual shelf brackets are not very stable laterally, once these strips get screwed to the risers, the whole unit will become very stable. Cork roadbed material can be added over the plywood.

Track: In order to keep costs down, I priced used switches and track found on eBay. However, if our modeler is a little more advanced and adventurous, they could choose to use Proto 87 Store fast kits. The budget for track also includes Caboose Industries ground throws.



contents



index

Power: Since at this point there is only room for one operator and one train, I began with a beginner-style DCC system: the MRC Prodigy. This is an inexpensive system for getting started. To reduce costs even further, a standard DC power pack could be used.

Structures: To keep the cost down, all of the structures are to be constructed of mat board with photo overlays until additional funds become available. If the modeler chooses, just temporary mock ups could be used as a starting point.

Scenery: I envision that most of the materials will be found and therefore are free. Examples include sifted dirt, weeds used for tree armatures, maybe even sifted stone for ballast. A few items will need to be purchased, such as ground foam, paints etc.

Locos and Rolling stock: Here is where I'm going to really step outside of the box. During different searches of eBay and Craigslist for items, I came across sales of large quantities of rolling stock and locomotives.

While some of these had an asking price of \$400-\$600, my idea is to purchase the lot, pick out the pieces that one would want for the layout, and then put the rest of them back up for sale at either a model railroad flea market or back on the internet.

With a little bit of luck and some good hunting, I believe that some rolling stock and locomotives could be had for free or near free. The key to making this work is to have the discipline not to keep everything that was purchased.

Industries:

- **Bowser Pump:** Manufactures gasoline pumps used at service stations. Inbound materials for manufacturing of gasoline pumps Outbound finished gas pumps by rail and truck.
- **Sunbeam Bakery:** A regional bakery for bread. Inbound flour shipped in Airslide hoppers; prior to Airslide hoppers,

box cars. Outbound no rail bakery goods shipped to groceries stores in the regional area.

- **Fort Wayne Electric (GE):** Manufactures electric motors and parts for appliances. Inbound products for electric motors, oil or coal for plant heating. Outbound finished motors by rail and truck.
- **Broadview Lumber:** Local lumber company. Inbound lumber. Outbound trucks only to local construction sites.
- **Rea Magnet Wire:** Manufactures copper wire for electrical motors. Inbound copper ingots, oil or coal for furnaces. Outbound spools of copper wire via rail and truck.

\$500 Starter Layout Contest Rules

Here are the rules for the MRH \$500 Starter Layout Challenge Contest we ran from August to November of 2012.

- You have a \$500 total budget.
- Assume basic tools: hammer, saw, drill, screwdriver, scissors, single-edged razor blades, soldering iron.
- Assume advanced tools like a table saw, router, or lathe are NOT available.
- Must design an operating layout or module (continuous running optional).
- Include a shopping list not exceeding \$500 - must cover benchwork, roadbed, track, wiring, control system, rolling stock, locos, structures, and scenery.
- Common items listed for sale on the web like eBay or Yahoo train yard sale okay.
- Thinking outside the box encouraged.



contents



index

- **Galduex Refinery:** Refines oil into aviation fuel and other refined products. Inbound chemicals needed to refine oil. Outbound refined aviation fuel.
- **Zolner Piston:** Manufactures pistons for the automotive industry. Inbound materials needed for casting pistons. Outbound finished pistons to various automobile manufacturers.
- **Fort Wayne News Papers:** Printers of the local Fort Wayne papers. Inbound newsprint. Outbound delivery by trucks to local cities and news stands.

I believe this layout design is a good beginner layout for a hobby newcomer to start their journey in the hobby, and I'd love to hear from any new model railroader who elects to build this or something inspired by it. 



The other winning contest entries will be published one per month for the next several issues of Model Railroad Hobbyist. Each layout plan presented represents a small layout you could build for \$500, which proves getting started in model railroading can be quite affordable with just a little cleverness!

END OF TRAIN DEVICE

FLASH CIRCUIT
UNDER TRUCK

TRACK
POWERED



READY TO RUN!

**Bright Red
Flashing Light!**

Installs in minutes
with no freight car
modification required!

RE RING
ENGINEERING

Patented Technology - US Patent 7,549,609

Does not affect Load!

↓ Car without Load ↓

↓ Car with Load ↓



For video
and more
click here!



Interested in O Scale?

THE

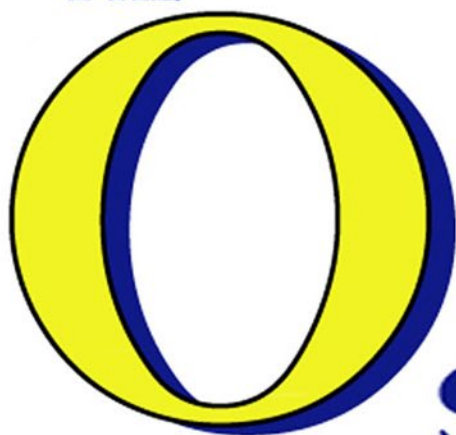

SCALE

RESOURCE.®

www.oscaleresource.com

Listings of O Scale manufacturers, dealers, and suppliers.



contents

index

Exceptional
Model Product

Exceptional
Products - past,
present, or future

**Model Railroad
Hobbyist magazine™**



PRODUCT SHOWCASE

→ Visit pwrs.ca



Reader
Feedback
(click here)



NARC: Canadian Pacific Multimark Hopper



[Click to view a larger version online.](#)

Over the next 10 pages, MRH presents a special product showcase of North American Railcar Corporation's Hawker-Siddeley 4550 cubic-foot cylindrical hoppers. These click-n-spins are all of the same HO scale hopper family, exhibiting their variations available in both **HO** and **N** scale.



Exceptional
Model Product

Exceptional
Products - past,
present, or future

**Model Railroad
Hobbyist magazine™**

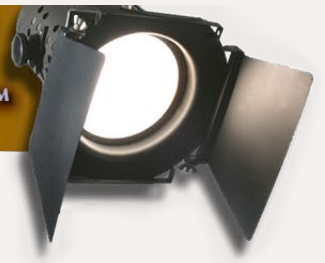

PRODUCT SHOWCASE

→ Visit pwrs.ca

Available in HO and N scale

NARC: Canadian National White Lettering Hopper



[Click to view a larger version online.](#)

Circa 1970, National Steel Car and Hawker Siddeley Canada both developed a 4550 cubic-foot cylindrical hopper for hauling grains or potash, chemicals and fertilizers. North American Railcar Corporation (NARC) is producing the “phase 6” car in **HO** and **N** as built by Hawker Siddeley Canada from October 1979 to October 1982.



contents



index

Exceptional
Model Product

Exceptional
Products - past,
present, or future

**Model Railroad
Hobbyist magazine™**



PRODUCT SHOWCASE

→ Visit pwrs.ca

Available in HO and N scale

NARC: Canpotex Limited - PTEX Hopper



[Click to view a larger version online.](#)

A joint Canadian National/Canadian Pacific team originally designed this 4550 cubic-foot 4-bay cylindrical hopper for hauling wheat and similar density grains (with trough hatches) and potash, chemicals and fertilizers (with round hatches). The National Steel Car, Hawker Siddeley Canada, and Marine Industries Limited designs came from this joint team design.



Exceptional
Model Product

Exceptional
Products - past,
present, or future

**Model Railroad
Hobbyist magazine™**

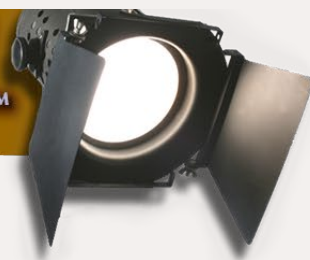

PRODUCT SHOWCASE

→ Visit pwrs.ca

Available in HO and N scale

NARC: Government of Canada - CNWX Hopper



[Click to view a larger version online.](#)

Over the life of this design, a number of variations were produced, resulting in changes such as the length of the side sill notch at the side ladders, the number of welded side panels, the number of running board supports and the position of the brake reservoir.



contents



index

Exceptional
Model Product

Exceptional
Products - past,
present, or future

Model Railroad
Hobbyist magazine™



PRODUCT SHOWCASE

→ Visit pwrs.ca

Available in HO and N scale

NARC: Saskatchewan Grain - SKNX Hopper



[Click to view a larger version online.](#)

HO scale models of these hoppers include #58 Kadee couplers, photo-etched metal parts, trucks with microprinting, accurate variations for each reporting mark, and semi-scale low-friction wheels. **N scale models** include Micro-Trains trucks & couplers, etched-metal roof walks, and factory applied grab irons.



Exceptional
Model Product

Exceptional
Products - past,
present, or future

**Model Railroad
Hobbyist magazine™**



PRODUCT SHOWCASE

→ Visit pwrs.ca

Available in HO and N scale

NARC: Canadian National White Outline Hopper



[Click to view a larger version online.](#)

Intermountain Railway Company (IMRC) also produced N and HO scale models of National Steel Car's 4550 cubic-foot car, which is similar to the HST version, but with detail differences. The NARC model is intended to compliment the IMRC version, as these are two distinct variations of 4550 cubic-foot cylindrical hoppers.



contents



index

Exceptional
Model Product

Exceptional
Products - past,
present, or future

**Model Railroad
Hobbyist magazine™**

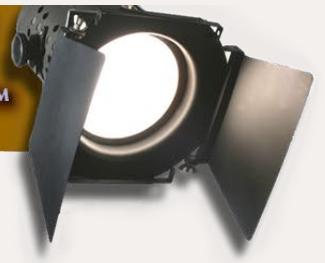

PRODUCT SHOWCASE

→ Visit pwrs.ca

Available in HO and N scale

NARC: Wheat Board of Canada Hopper



[Click to view a larger version online.](#)

These phase 6 HST cars have an elongated, 4-piece trough hatch, a wide triangular running board extension support and 11 running board supports (narrow intermediate supports and wide supports at the running board panel joints).



Exceptional
Model Product

Exceptional
Products - past,
present, or future

**Model Railroad
Hobbyist magazine™**



PRODUCT SHOWCASE

→ Visit pwrs.ca

Available in HO and N scale

NARC: Saskatchewan Grain - SKPX Hopper



[Click to view a larger version online.](#)

These cars come equipped with truck-mounted brake cylinders, so the brake reservoir is mounted to the shear plate (the end platform between the side sills) parallel to the coupler end of the shear plate.



contents



index

Exceptional
Model Product

Exceptional
Products - past,
present, or future

**Model Railroad
Hobbyist magazine™**



PRODUCT SHOWCASE

→ Visit pwrs.ca

Available in HO and N scale

NARC: Government of Canada - CPWX Hopper



[Click to view a larger version online.](#)

At the bolsters these cars have jack pad/pulling faces which are perpendicular to the ground with a rectangular hole in the face, there are nine welded side panels (wide and narrow) and the end panels are narrower at the side sill than at the top.



Exceptional
Model Product

Exceptional
Products - past,
present, or future

**Model Railroad
Hobbyist magazine™**



PRODUCT SHOWCASE

→ Visit pwrs.ca



Reader
Feedback
(click here)



NARC: Saskatchewan Potash Corp Hopper



[Click to view a larger version online.](#)

These **HO and N scale** Hawker Siddeley 4550 cubic-foot 4-bay cylindrical hopper from North American Railcar Corporation are available now, so visit the [Pacific Western Rail Systems](http://pwrs.ca) website to get your cars while still available.



contents



index



*The Old
Yardmaster*



**Reader
Feedback**
(click here)



January 2013: The latest model railroad products, news & events

by Richard Bale and Jeff Shultz

Hurricane Sandy

Few hobby stores in the northeast reported any physical damage from Hurricane Sandy, but several lost power for a week or more. That essentially shut down their ability to make sales or process on-line orders. Taking advantage of a power outage that shut down the alarm system at Willis Hobbies, in Mineola, New York, burglars broke through a front window and stole about a dozen high-end radio-controlled cars. For the next five nights, owner Steve Ford and his brother remained on guard by sleeping at the hobby store until power was restored. Zeppelin Hobbies & Raceway in Wayne, New Jersey; Hobbymasters in Red Bank, New Jersey; Trainworld in Brooklyn; and Trainland in Lynbrook, New York were all shut down due to power loss. Several other hobby stores in the northeast experienced similar losses ...

Railway Engineering moves to Arizona

Family health issues have prompted Steve Hatch to relocate his enterprise to sunny Arizona. The new address is Railway



Engineering, 9030 Smoki Trail, Dewey, AZ 86327. The company offers a wide selection of handcrafted turnouts in most popular scales. For details visit railwayeng.com ...

New Club in Minneapolis Area

Jeff Dombrowski reports that a new club has been established in a 5,000 sq ft space in Coon Rapids. Calling itself the North Metro Model Railroad Club, work is already underway to model the BNSF from Northtown Yard to Duluth. For additional information including details on membership contact Jeff at jeffery@yahoo.com ...

Tom Doherty 1942-2012

Thomas Norman Doherty, a resident of Robeson Township, Pennsylvania, died December 6, 2012. A native of Philadelphia, Tom studied at the Massachusetts Institute of Technology and Drexel University. His career as an electrical/nuclear engineer included work at Univac, CDC, Grumman, TWA, Firestone, Bechtel, and GE. Tom is best known in the model railroad community as the owner of Pennsylvania Heritage Models where he produced award winning model trains and trolleys. He was also active with several railroad preservation organizations. Tom worked extensively on Reading Birney #506 and a Philadelphia trolley now on display at the Electric City Trolley Museum at Scranton, Pennsylvania. Tom is survived by his wife Ann, two children, and four grandchildren ...

Gordon North 1931-2012

Gordon North of Rockville, Maryland, lost his battle with cancer in early December. Considered by many to be the father of On2-1/2 (aka On30), Gordon pioneered the concept of building O scale narrow gauge equipment on HO scale chassis and operating on HO gauge track. As far back as the 1950s, Gordon authored numerous articles that focused on On30 in



contents



index

several hobby magazines, most notably the Narrow Gauge & Short Line Gazette. He delighted in converting HO mechanisms, such as Mantua 2-8-2 chassis, into smooth-running On30 Consolidations. He also pioneered converting a variety of HO diesel chassis into On30 “critters” many of which were featured in Bob Brown’s Gazette. Gordon’s varied interests included electronics, which allowed him to build his own sound system before such things became available commercially. During his service to the nation in the U.S. Navy, Gordon was a member of the team that developed the proximity fuse which detonates the Patriot missile when it closes on an enemy target. Gordon North will be interred at Arlington National Cemetery...

Wolfgang Richter 1928-2012

Wolfgang Richter, co-inventer of G-scale trains, died November 28, 2012. He was 84 years old. Wolfgang was co-owner and general manager of German toymaker E. P. Lehmann when he and his brother Eberhard introduced the LGB brand of G-scale trains in 1968. LGB equipment utilized weather resistant materials making it practical for outdoor use which ultimately led to the popularization of the garden railway hobby. The Model Railroad Industry Division of the Hobby Manufacturers Association elected Wolfgang to its Hall of Fame in 2002. Although Richter continued as the principal spokesperson and promotional ambassador of LGB, executive management of the company was passed to his son Rolf (also deceased) who led Lehmann until the firm was forced into bankruptcy in 2006. The company has since been acquired by Märklin...

Now for a look at some new model railroad products...

NEW PRODUCTS FOR ALL SCALES

Iowa Scaled Engineering (iascaled.com) is selling MRServo as a cost-effective way to add slow-motion turnouts to your layout. They are reported to be suitable for space-constrained applications and multi-deck layouts. Optional PowerFrog technology provides reliable, short-proof power routing to solid frog turnouts. Three versions are available with kits beginning at \$12.00 each. Visit the above website for additional information.

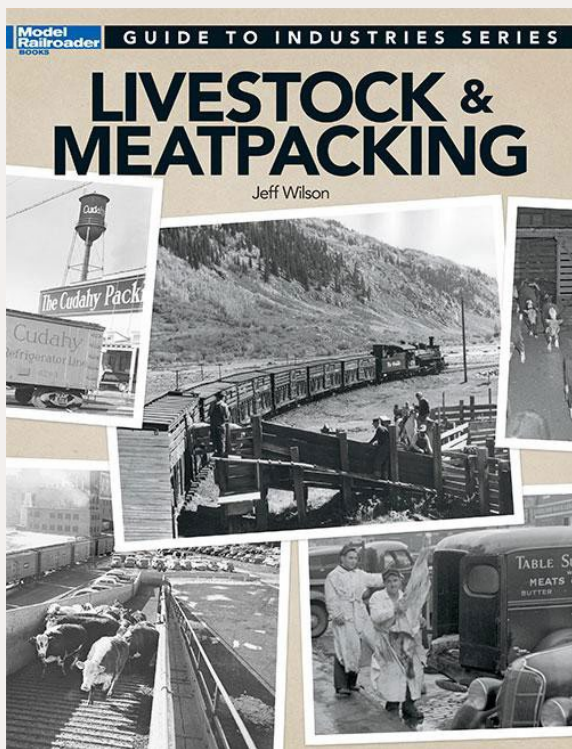

The newest book in Kalmbach's (kalmbachstore.com) Guide to Industries Series is "Livestock & Meatpacking." Author Jeff Wilson describes the vital role of railroads in the development and success of the meatpacking industry. Details on how the railroads hauled livestock as well as finished meat products, and the specialized equipment that was needed to accomplish the job are all covered.

Wilson explains livestock traffic, stockyard operations, dedicated meat train operations, regulations, and scheduling. Some 170 prototype photographs, including 30 in color, plus charts and maps of stockyard locations combine to make this a valuable and interesting resource for model railroad hobbyists. The softcover 8.25 " x 10.75" publication is available at hobby and book stores or direct from Kalmbach at \$19.95.



contents



index

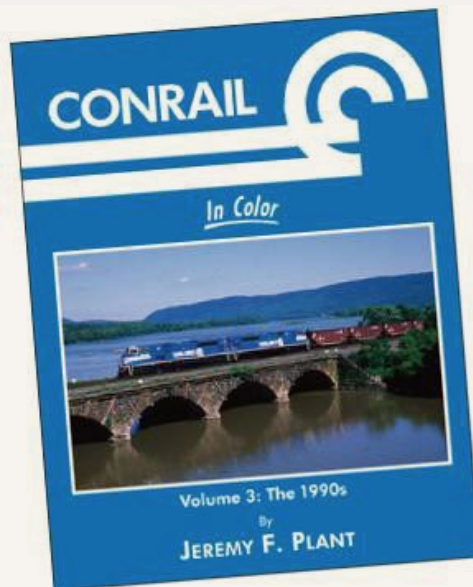
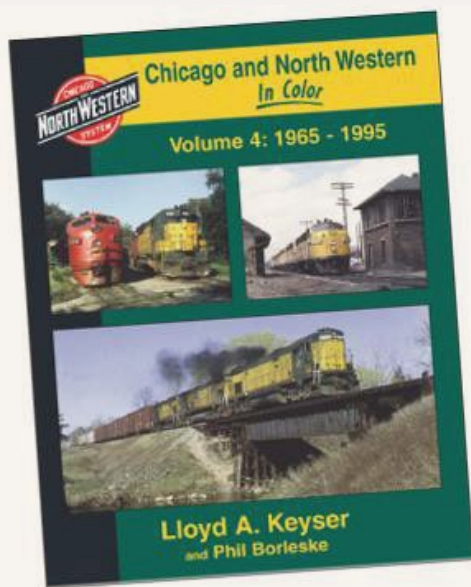

Morning Sun Books (morningsun-books.com) has released "Chicago & North Western In Color Volume 4: 1965-1995." Written by

Lloyd A. Keyser and Phil Borleske, this volume is the concluding chronology in the C&NW series. Also just released is "Conrail In Color Volume 3: 1990s" by Jeremy F. Plant. This volume covers the final years of Big Blue before the railroad was absorbed by CSX and NS. The books have an MSRP of \$59.95 each.

Olin's Depot (olinsdepot.com) is selling a track occupancy detector specifically designed for use on layouts using Digital Command Control (DCC). OC1 is a four-segment DCC block occupancy detector that is completely powered from DCC, and provides four optically-isolated outputs with a common ground. The manufacturer states that a single axle with a 10 kΩ resistor between the wheels can be reliably detected. Pricing begins at \$59.95 for a four segment detector. Complete specifications are available at the above website site.

NEW LARGE SCALE PRODUCTS

Kadee Quality Products Company has introduced a remote uncoupling system that is entirely wireless and can function up to 300 feet away from the hand-held transmitter. The system is

currently available for G scale equipment only. Remote uncoupling for Number 1 scale is expected to be announced soon. Equipment for other scales is not available at this time. The uncoupling system operates entirely independent of any track signal. A basic starter kit that includes a hand-held transmitter, a body-mount coupler kit, and a receiver sells for \$349.99. An extensive FAQ can be accessed at remoteuncoupling.com/html/support.htm#Frequently_Ask_Questions.



NEW PRODUCTS FOR O SCALE

Atlas-O (atlaso.com) plans to deliver another run of its popular O scale caboose. The ready-to-run model is based on a prototype built by International Car Company with both standard and extended view cupolas. Atlas's extended view caboose will be available decorated for Atchison, Topeka & Santa Fe; Denver & Rio Grande; and Maine Central. Cars with standard cupolas will be available for Great Northern, Norfolk Southern, Norfolk & Western, and Northern Pacific. Undecorated models will be available in both styles of cupola. The model has interior lighting, full interior details including crew figures, flashing warning light at the rear, metal grab irons, and Barber Bettendorf-type caboose trucks with rotating bearing caps. A 3-rail version with



contents



index



optional scale couplers will list at \$79.95. The 2-rail version will list at \$84.95 each. Availability is planned for the second quarter of this year.

Atlas-O will release a new run of its O scale model of a Thrall-built articulated auto carrier with delivery set for the third quarter of 2013. New paint schemes will be available for FXE, FOKL, Norfolk Southern, and TTX as seen here. Special details include operating end doors, detailed interior decking, separately-applied wire grab irons, complete brake line details, and 70-ton roller-bearing trucks. The model is 35" long and comes with an adjustable articulated diaphragm with curvature settings for O-42, O-54, and O-63 operation. The 3-rail version has an MSRP of \$134.95 and requires a minimum radius of 42" for reliable operation. The 2-rail version lists at \$141.95 and requires a 36" minimum radius.

NEW PRODUCTS FOR HO SCALE



Accurail (accurail.com) has listed several new freight car kits this month including a Baltimore & Ohio 40' wood reefer with a fishbelly underframe at \$16.98. The ends, roof and underframe are all oxide red.



Accurail is selling a pair of Soo Line 40' PS-1 steel boxcars in a 2-pack at \$29.98.

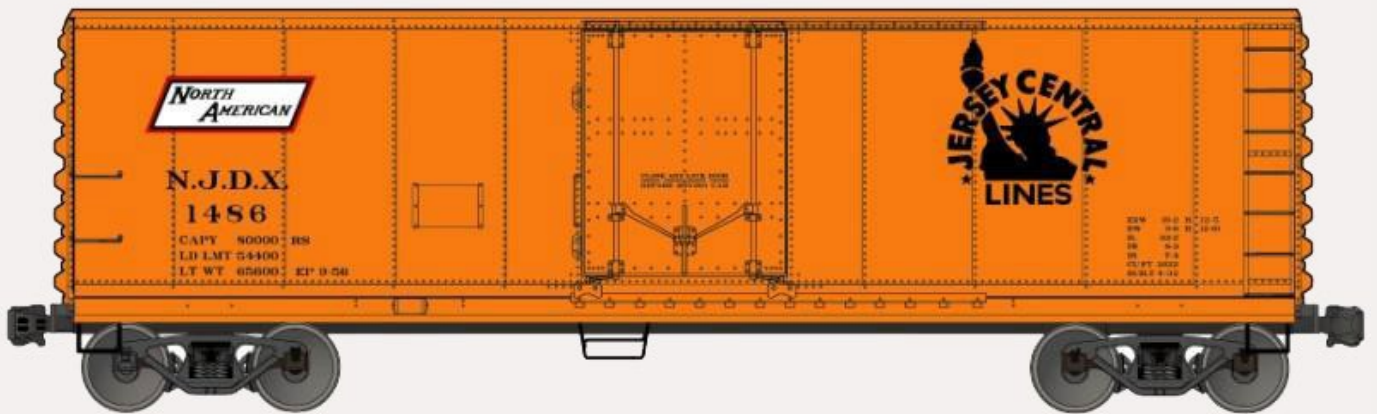

Also available now is an NJD-X-Central New Jersey 40' plug-door steel refrigerator car at \$16.98.



Kits for a 55-ton USRA twin-bay hopper decorated for Virginian are available in a 3-pack at \$42.98.

Additional HO scale kits from Accurail include a Norfolk & Western 50' combo-door boxcar decorated in dark blue with



contents



index

mineral red doors at \$15.98; a Louisville & Nashville steel box-car at \$15.98; and a Rock Island 50-ton offset-side twin-bay hopper car at \$15.98. Limited run sets of car kits currently available include a 3-pack of Pennsylvania USRA twin-bay open-top hopper cars painted black with white 1960s-era lettering at \$42.98, and a 3-pack of Southern Pacific 40' single-sheathed, outside-braced wood boxcars at \$44.98. The SP set includes one each of a 6-panel car with metal ends, an 8-panel car with wood doors and ends, and an 8-panel car with wood doors and metal ends. All prices quoted are MSRP. Accurail models are HO scale kits and include appropriate trucks and Accumate couplers.

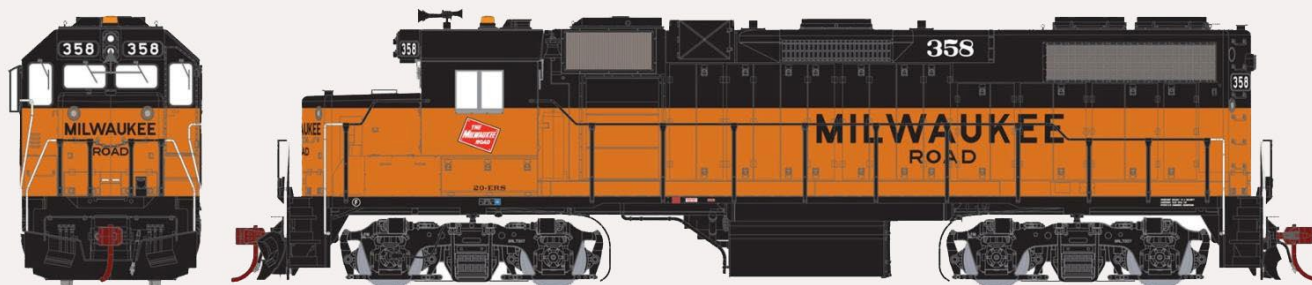

Athearn (athearn.com) has scheduled another release of GP38-2 Phase 1 diesels for late June. Decorating schemes on the HO scale Genesis series locomotives will include Burlington Northern (green), Milwaukee Road, Norfolk Southern, Rock Island, and undecorated. Non-sound models will be DCC-ready using Quick Plug™ technology. They will have an MSRP of \$189.98 each. Sound-equipped models have Soundtraxx® Tsunami® DCC decoders and have an MSRP of \$289.98 each.

Several details such as snow plows, front steps, ditch lights, exhaust stacks, horns, antenna, cab sides, mirrors and sunshades, dynamic brakes, and bell location will vary depending on the prototype practice of the road being modeled. Other

variables include the size of the fuel tank (1700, 2600 or 3600 gallon) and either type B or type M Blomberg trucks. All of the details are itemized in Athearn's new on-line catalog that can be viewed at the above website.

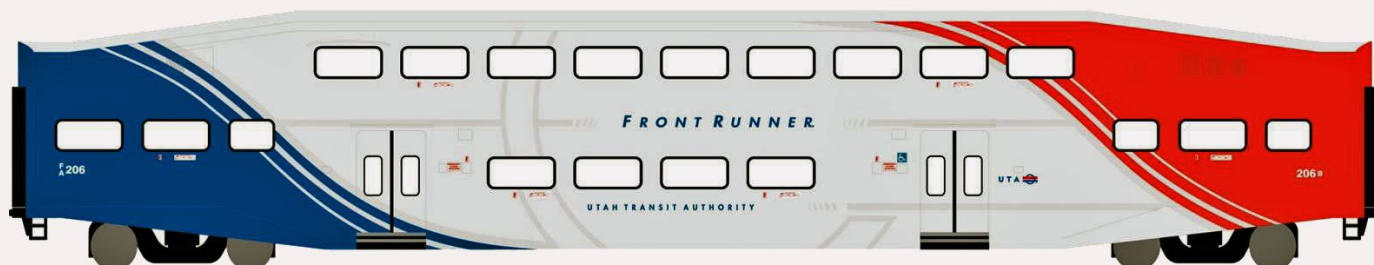

Also coming in late June are Bombardier bi-level commuter coaches and coach-cab units decorated for Utah Front-Runner, Seattle Sounder, LA Metro Link, and Cal Train. Features include see-through windows, detailed interior, diaphragms, and separately-applied grab irons. Coach-cab cars have a horn and bell and will be available individually at an MSRP of \$49.98. Coaches will be available in 3- packs at an MSRP of \$149.98.



Athearn will soon offer HO scale 50' flat cars with two 25' removable trailers at an MSRP of \$33.98. Three road numbers each will be available for Pennsylvania Railroad, Canadian National, Union Pacific, and Milwaukee Road as seen here. Availability is expected in June.



contents



index

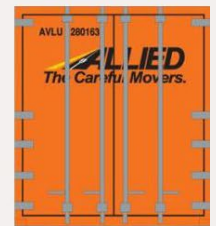

New 48' containers will be available from Athearn in 3-packs at an MSRP of \$32.98 for Conrail/Mercury, CN/Intermodal, BNSF/Wedge, and Allied as seen above.



Athearn has scheduled a late June delivery date for new 40' container chassis including the K-Line version shown above. Other schemes will be MSL, MOL, MAERSK, CMA/CGN, and CHINA. The trailers will come in 2-packs with an MSRP of \$32.98.

HO scale Husky Stack well-cars will also be arriving in late June in three numbers each for TTX/Forward Thinking, CSX/Intermodal, and BNSF at \$27.98 each.



DCC ready SD40T-2 diesel locomotives in Athearn's ready-to-run series will be available in June at an MSRP of \$134.98. Three road numbers will be offered for Union Pacific, KCS, D&RGW, and NYS&W as seen above.



Athearn has scheduled an October release date for another production run of its Union Pacific FEF-class 4-8-4 steam locomotives with 7-axle centipede tenders. Six of the locomotives will be offered in three paint schemes: Numbers 837 and 8444 in UP's greyhound livery shown above with elephant-ear smoke lifters; locomotives 842 and 844 also have smoke lifters and will be painted black with a grey smoke box; numbers 825 and 832 are also black with a grey smoke box but without smoke lifters.

A summary of key features on the HO scale ready-to-run model include lighted number boards, metal handrails, adjustable cab windows, full details and printed gauges on the boiler backhead, and blackened metal wheels. A front coupler pocket (included) can be inserted to mount an operating coupler. Individually-applied details include brass-painted bell and whistle, piping, valves, generator, steps, air pump, air tanks, reverse gear, and an uncoupling bar. A DCC decoder with SoundTraxx® Tsunami® sound is mounted in the tender. Sounds include synchronized exhaust, whistle, bell, blow-down, air compressor, dynamo, and pop-off valve sounds. User-controlled functions include whistle, bell, wheel squeal, coupler crash, injector, water stop, and light dimmer. A minimum radius of 22" is recommended. All versions have an MSRP of \$549.98 each.

Atlas Model Railroad Company (atlasrr.com) has scheduled a third quarter release of a GP40-2(W) locomotive. The HO scale model



contents



index

is based on a group of eleven diesels built for GO Transit (the Ontario provincial government commuter service) which were later sold to CN and numbered in 9668-9677. Prototype specific details on the Atlas ready-to-run model include two styles of long-hood (CN single light without number boards and GO Transit dual lights with number boards and classification lights), 3,000 gallon fuel tank, optional CN-style working ditch lights, optional snow shields over air intakes, round or square sand hatches, cab-mounted bell, three-chime air horn, and etched-metal radiator fan grilles.

Standard features on all Atlas GP40-2 models include golden-white LEDs, directional lighting, cab interior with crew, movable drop steps, walkway safety tread, uncoupling levers, MU and trainline hoses, snow plow, windshield wipers, individual grab irons, and fine-scale handrails. Road names available on this run will be Aberdeen, Carolina & Western; CN (zebra stripes, as seen here); CN (CNNA); Central Michigan; Huron & Eastern; Pan Am Railways; and GO Transit (new road numbers). Undecorated models will be available for early GO Transit versions, and both early and late CN versions.

Each roadname will be available DCC-ready (Atlas Master™ Silver series at \$169.95) with an NMRA plug for an aftermarket decoder. Also DCC and sound equipped (Atlas Master™ Gold Series at \$259.95) with QSI® Quantum System™ sound and Dual-Mode® Decoder (e-DMD) that allows operation in DCC or analog DC. QSI includes dual speakers, diesel engine sounds, squealing brakes, doppler effect, air release in neutral, and coupler impact sounds when operated with DCC Helper mode that mutes the whistle and bell for double heading. Atlas cautions that due to the higher starting voltage required to

operate the sound system, it is not possible to MU a non-sound loco in DC (analog) mode.

Here's an early look at a new HO scale NRE Genset II locomotive in the works at Atlas. The prototype features reduced fuel consumption and low exhaust emission. Power is generated by two or three independent 700 hp diesel engines that engage and disengage as more or less horsepower is required. Gensets are preferred in metropolitan areas where air pollution is closely monitored.



Due in the second quarter of 2013, Atlas's HO scale version will be produced from all-new tooling. It represents the second phase of production by the National Railroad Equipment Company and is unofficially referred to as the "Genset II". Primary spotting features from earlier prototypes are the longer hood that includes a provision for dynamic brakes, and a noticeably shorter low hood resulting from the cab being moved forward on the frame. The Atlas Trainman® series DC model will have an NMRA plug to accept after market decoders. The MSRP will be \$144.95. Road names will be Belt Railway of Chicago, BNSF, Canadian Pacific, CSX (blue and yellow), Indiana Harbor Belt, and NRE Demonstrator. An undecorated model will also be available.

Atlas has upgraded the tooling for its Master® series cylindrical hopper cars with several new features including see-through



contents



index



roof walks, detailed brake gear, and 100-ton trucks with blackened metal wheels. The next production run is scheduled for release during the third quarter of this year. Introduced in 1961 by American Car & foundry, Atlas's HO scale version will be available with three discharge bays decorated for Agrico (SHPX), Amerthene (NAHX), Dresser Minerals (NAHX), and Huntsman Chemical (JHPX). The same cylindrical hopper car with six bays will be available for Southern Pacific and Wabash, as seen here. The ready-to-run cars have an MSRP of \$31.95. Undecorated versions will also be available at \$24.95 each.

Atlas will release its HO scale AAR 50' single-door boxcar decorated for Canadian National, N de M, Penn Central, and Santa Fe during the second quarter of this year. The production run will include cars with new road numbers for Bangor & Aroostook and Maine Central. Prototype specific details include 8' and 9' Superior or Youngstown doors, and three types of side sills -- straight, tabbed and fish-belly. The HO scale ready-to-run cars have an MSRP of \$29.95. An undecorated model will be offered at \$24.95.

Bachmann (bachmanntrains.com) has added sound to its HO scale DCC-equipped ALCo RS-3 diesel locomotive. The



new SoundTraxx® package includes the sound of the prime mover, three air horns, a short horn blast, and bell. Additional features on the RS-3 are all-wheel drive with a can motor, metal uncoupling levers, blackened metal wheels, and directional headlights. The ready-to-run model has an MSRP of \$199.00 and is available decorated for Delaware & Hudson (blue and grey), CP Rail (red, black and white), Boston & Maine, Erie (above), and L&N (black, cream and red).



Blackstone (blackstonemodels.com) is selling HO_n3 scale models of Denver & Rio Grande Western UTLX and CYCX narrow frame tank cars. The UTLX car has yellow lettering and is available in three numbers. The CYCX car has gothic white lettering and is available in two numbers. The ready-to-run models come in standard paint at \$67.95 each or weathered at \$75.95.



contents



index

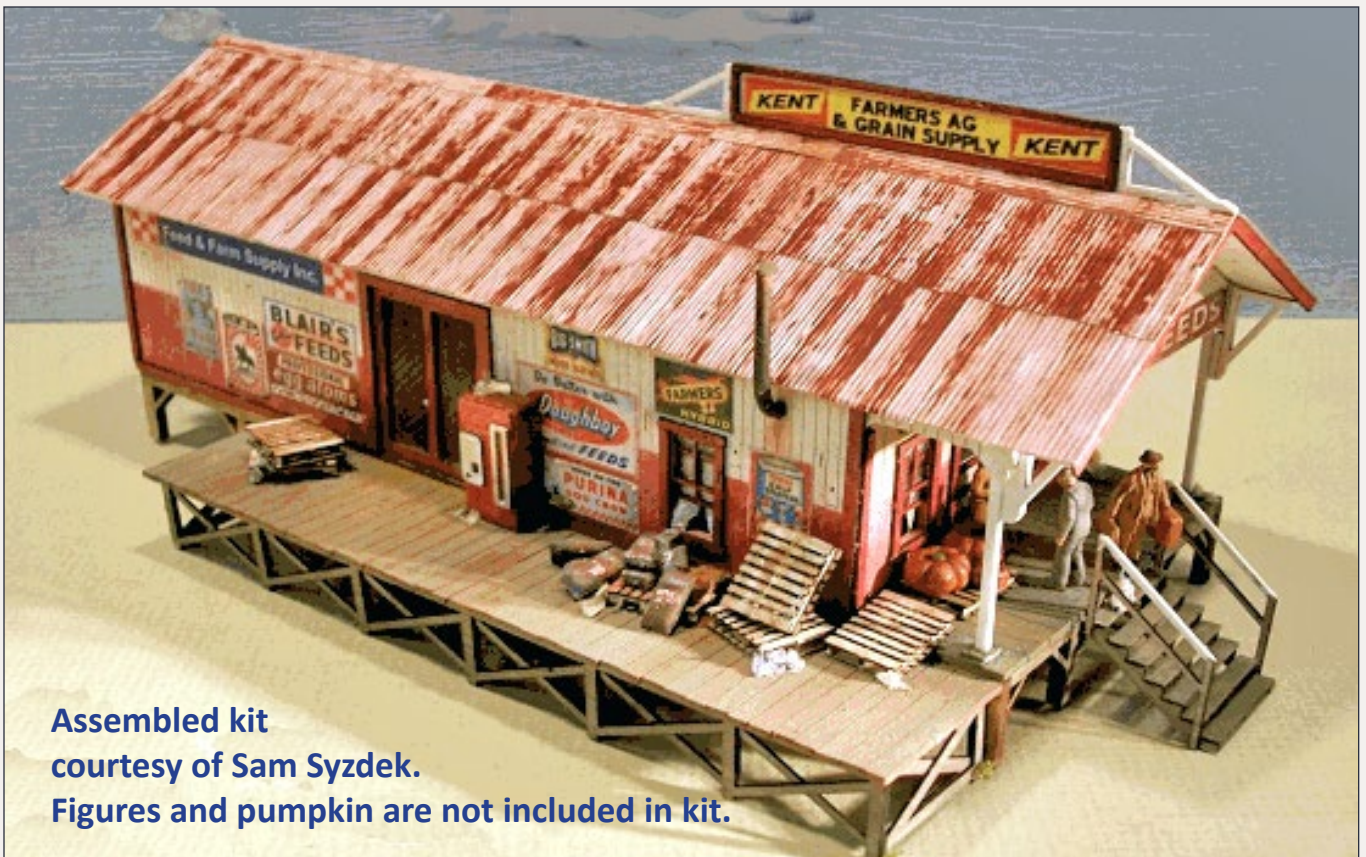

Assembled kit
courtesy of Sam Syzdek.
Figures and pumpkin are not included in kit.

Blair Line LLC (blairline.com) is working on an HO scale structure kit for Greene's Feed & Seed. The structure features tab and slot construction. The sides of the structure are composed of laser-cut planks with nail holes, knots, and other detailed imperfections. The doors, windows, and corner trim are laser-cut peel-n-stick material. Windows are positionable and the corrugated roof material is pre-weathered. An assembly jig is provided for the laser-cut stair components. Pallets, eave brackets, feed sacks, and a soda pop machine are all laser-cut. Other details include a cast metal smoke jack and a variety of signs. The loading dock, which can be positioned on either side of the main building, features laser-etched nail holes in random length floor planks. The HO scale kit is scheduled for release in early July at an MSRP of \$69.95. The assembled structure has a footprint of 7.20" x 2.80". The dock measures 5.60" x 1.10".

Bowser (bowser-trains.com) has scheduled a new production run of its Executive series 100-ton triple-bay open hopper

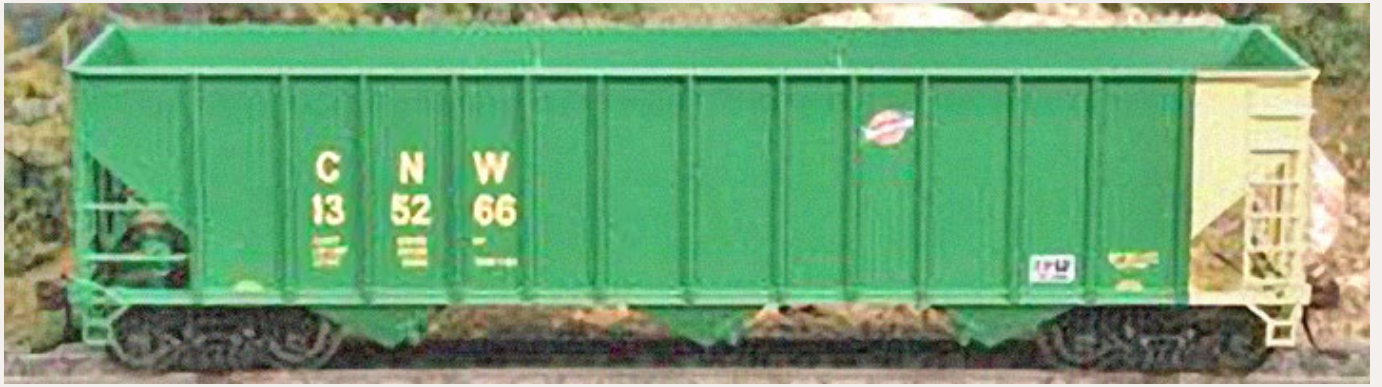

car. Orders are being accepted through the end of January for delivery this fall. Except as noted, three road numbers will be available for R&N-Reading & Northern (black body red end), R&N (black body blue end), PPLX-Pennsylvania Power & Light (yellow ends, one road number only), PPLX (single yellow end, five road numbers), PRR (yellow dot), Wheeling & Lake Erie, NS (new logo), PPLX (Ready Kilowatt), C&O (Progress), Conrail, NS, NW, C&NW (green body, yellow end, see above), and six road numbers each for C&O, B&O, and WM all with Chessie Cat logo. The models have knuckle couplers and metal wheelsets. They will be molded in USA then sent to China for assembly and packaging. The MSRP will be \$24.95.



Last month we reported on Bowser's new Executive Line ALCo Century series C430 diesel locomotive currently under development. We can now confirm road names and provide some samples of art work for the HO scale ready-to-run model that will be available this fall.



contents



index

Road names will be New York Central, Penn Central, Reading, Seaboard Coast Line, Louisville & Nashville, CR Reading (patch), Conrail (black), and Conrail.



Also Western New York & Pennsylvania (red), Western New York & Pennsylvania (black), Morristown & Erie, Green Bay & Western, Green Bay & Western (grey stripe), Susquehanna (early scheme), Susquehanna (late scheme, above), and ALCo demonstrator (below).



The Executive Line model will have separately-applied grab irons, a can motor with flywheel, Kadee[®] couplers, and directional lighting with golden-white LEDs. The ready-to-run models will come with different fuel tanks, air intakes, and either Hi-Adhesion or AAR 'B' trucks per prototype road practice. Analog DC versions with an NMRA plug for an aftermarket DCC decoder will have an MSRP of \$199.95. DCC versions featuring LokSound Select Dual –Mode decoder (for operation on DC or DCC) will have an MSRP of \$299.95.

Bowser has released more details on its new HO version of PRR class H30 triple-bay covered hopper we reported on last

month. Six PRR decorating schemes for class H30 C-hop include plain, circle, and shadow Keystone heralds on gray cars. Cars painted red oxide will have a circle Keystone and a plain Keystone with a black “S”. The plain Keystone will also be applied to a car with a yellow body. Two of the 1973 cu ft triple-bay 10-hatch cement-hauler will be available in Penn Central green (one for interchange and one designated for MOW service). Gray cars decorated for Norfolk & Western and Conrail will complete the run. Delivery of the newly-tooled HO scale model will be this fall at an MSRP of \$29.95.



Broadway Limited (broadway-limited.com) will begin shipping a new PRR 4-4-4-4 class T1 steam locomotive in February. Features of the HO scale ready-to-run model include Paragon2 sound and control system with synchronized smoke and exhaust sound, integral DCC decoder with back EMF, 5-pole can motor, golden white LED headlight and rear light, molded ABS plastic body, die cast metal chassis, metal Kadee-compatible couplers, electrical pick up on all drive wheels, separately applied handrails, ladders, whistle, and brass bell, and operating cab roof vents. A minimum radius of 22” is recommended for the model. BLI’s PRR T1 has an MSRP of \$499.99. Details on different liveries and road numbers available on this production run can be viewed on BLI’s website.



contents



index



Prototype photo courtesy of Joe Shaw

Reservations close January 15, 2013, for **BLMA's** (blmamodels.com) new variation on its popular Norfolk Southern class G-85R/G98R TopGon coal cars. Cars in this fourth production release will feature a smooth tub underframe without the ribbed braces. The car will be available in 24 numbers with each road number displaying specific light and loaded weight data. The injection molded plastic cars will have separately applied wire grab irons and uncoupling levers, etched-metal brake wheel platforms, accurate internal bracing, 100-ton trucks with metal wheels, and Kadee® #58 couplers. The HO scale ready-to-run cars will have an MSRP of \$32.95 each. Delivery is planned for the fourth quarter of 2013.



Central Valley Model Works (cvmw.com) is selling a new undecorated body kit for a Northern Pacific 41' flat car. The prototype was rebuilt from wood boxcars in NP's own shops in the early 1930s. The HO scale kit consists of a molded styrene body with wood grain planks and detailed

stake holders. Grab irons, trucks, couplers, and decals are not included. The kit is priced at \$12.95 and has material to build two flat cars. CVMW sells appropriate NP decals as a separate item. They include original lettering material as well as data for the 1960s-era cars. The decal sheet is \$6.25 and has sufficient material to letter two flat cars.

Classic Miniatures, a division of Trout Creek Engineering Inc. (troutcreekeng.com) reports that several HO scale kits including Ophir Depot (item 31156), Queen Anne Cottage (item 38903), Mine House (item 38907), and Nevada City Fire House (item 38912) are all currently available. Owner Cliff Mestel said the Genoa Saloon (item 38920) is undergoing some additional work but should also be available soon.

ExactRail (exactrail.com) continues to make progress on its HO scale model of a Thrall 63' center-beam flat car, however, the release date has been postponed from December to the first quarter of 2013. It seems the combination of etched brass parts and molded plastic details make the model a challenge to assemble and paint. Initial decorated samples were rejected and it became clear that new assembly fixtures and paint masks would be required, thus causing a delay in the release date of the ready-to-run model.

InterMountain Railway Company (intermountain-railway.com) has announced new decorating schemes coming this summer for its postwar 10' inside height boxcar. The ten-panel car with a Youngstown door will be available in six numbers each for Kansas City Southern, Clinchfield Railroad, New York Central, Erie Lackawanna, Southern Pacific (sans serif lettering), N de M



contents



index

(Ferro-Tierda), Chesapeake & Ohio, and Penn Central. The HO scale ready-to-run model will come with etched-metal running boards, metal wheelsets, and Kadee® couplers. Final pricing is TBA.



Next month, **Kadee** (kadee.com) will release an HO scale ready-to-run model of a PS-2 covered hopper decorated for ATSF in 1957 factory-new boxcar red. Spotting features of the nicely detailed car include eight round roof hatches. The model will have an MSRP of \$42.95 each.



Kadee's March delivery schedule calls for the release of a Wabash PS-1 40' boxcar with an 8' Pullman-Standard door. The ready-to-run car is decorated in as-new 1957 red oxide with a DF slogan and flag-in-heart herald. The HO scale model has an MSRP of \$33.95 each.



Also due in March from Kadee is a Soo Line PS-2 two-bay covered hopper with hat rib sides and eight round roof hatches. The HO scale ready-to-run car will have an MSRP of \$42.95.

NKP Car Company (nkpcarco.com) will soon announce availability of three new HO scale etched brass kits for creating “Betterment” or Streamstyled Pullman heavyweight sleepers. The kits will include a 12 section, 1 drawing room car; an 8 section, 1 drawing room, 2 compartment car; and a 14 section sleeper. When pre-war lightweight streamline parlors and sleepers were introduced, some older heavyweight cars were modified with a so-called “Betterment” visual appearance so they could be operated with the newer lightweight cars. According to NKP the new modification kits will have correctly tapered “Betterment” roofs, ends, and skirting combined with Branchline sides, floor, trucks, and all the required detail parts. NKP Car Co. produces a full line of both heavy and lightweight passenger cars made to a specific prototype to accurately model a particular railroad or train. Visit the above website for additional details.

This month, **Rapido Trains Inc** (rapidotrains.com) will release its HO scale ready-to-run Osgood-Bradley 10-window coaches decorated for Bangor & Aroostook and Long Island MTA. Dashing Dan



contents



index



versions of the Long Island cars, as well as Penn Central cars, are expected to be available next month.



Rapido is progressing well in the development of a Canadian National F9B unit. Among the many unique features of the CN locomotives are the single louver rather than a center porthole, correct roof-mounted coils (different for each locomotive number), distinctive roof and end generator details, see-through non-warping etched metal grilles (backed with visible free-standing coils), uncoupling bars, steam blowdown valves, and metal Macdonald-Cartier couplers. Additional features include separate grab irons, and stainless-steel wheelsets.

In order to accurately replicate each of CN's four F9B units, Rapido is preparing tooling for four different shells. They include GPB-17a/b - #6600-6613 as built in 1954-55 with large steam generator

exhaust stacks on the end; GPB-17a - #6600-6610 as rebuilt with plated-over exhaust holes on the end, rounded steam generator exhaust stacks on the roof, and large winterization hatch ; GPB-17c/d -#6614-6630 with small winterization hatch and squared-off steam generator exhaust stacks on the roof; and GPB-17e - #6631-6637 with 48" fans and squared-off steam generator exhaust stacks on the roof.

Rapido will offer both powered and non-powered versions of the F9B. Powered models will be available for DC operation or with DCC using Rapido's distinctive 567C sound recording as used on Rapido's FP9A. Click here to see and hear Rapido's FP9A in operation: [youtube.com/watch?v=6QqGH2cTAQg&list=UU2ZSK39QhYnHWbnS9j0dwMA&index=7](https://www.youtube.com/watch?v=6QqGH2cTAQg&list=UU2ZSK39QhYnHWbnS9j0dwMA&index=7).

Late last month **Tangent Scale Models** (tangentscalemodels.com) introduced an all-new HO scale model of a General Steel Casting 60' flat car. Here are more details on this exceptional model that replicates a prototype with a one-piece cast steel frame developed in 1956 by GSC. The model is currently available in six prototypically accurate decorating schemes including Wabash in the road's 1956 brown scheme with white lettering.



An Atchison, Topeka, & Santa Fe class FT-7 version comes in the original 1956 paint scheme with white stencils on a red car body, an Illinois Central car in the original 1962 paint scheme with white lettering on a brown body, and a Pennsylvania Railroad version in original F47 red paint from 1965.



contents



index



A distinctive Missouri Pacific patch version of the car is available in UP 1980s MOW green scheme with several different black and white stencils, plus paint-outs and post-2004 conspicuity stripes; and a St. Louis Southwestern car in a 1956 scheme with white lettering including COTTON BELT across the black body. All road names are available in six numbers except the MP car which comes in four numbers. Undecorated versions of the GSC flat are available both with and without oval hole cutouts in the car side.

The models feature Tangent's usual attention to detail including wire grab irons, wire uncoupling bars, air hoses, Kadee® couplers, and either roller or plain bearing trucks as appropriate to the prototype road being modeled. The ready-to-run cars are priced at \$32.95 each. Note that Tangent allows mixing for multiple car discounts on quantity purchases in increments of 6, 12, 36 and 48. Visit the above website for full details.



Walthers (walthers.com) is selling a 50' AAR double-door boxcar decorated with two numbers each for Kansas City Southern (Southern Belle logo), Nickel Plate Road, Southern Pacific (black and white herald), and Santa Fe (El Capitan) as seen above. The HO scale cars have 5/5 Dreadnaught ends and two Youngstown

corrugated doors on each side. The ready-to-run limited edition WalthersProto™ models have an MSRP of \$34.98 each.



Walthers has produced four road-specific versions of EMD's GP60 diesel locomotive. The HO scale Proto2000® model is available decorated for BNSF (Bold Santa Fe on blue body, with yellow cab and nose), Norfolk Southern (Horse head logo), Union Pacific, and DRGW (Rio Grande) as seen above. Each road is available in two numbers with numerous prototype specific details all of which are itemized on the above website. All versions have metal lift rings and grab irons, 14:1 helical gears, constant and directional LED headlights, and a ditch light installation kit. The locomotives are available for standard DC operation at an MSRP of \$199.98, or with factory-installed Tsunami® Sound and DCC decoder at \$299.98.



Scheduled for release this month is a new run of WalthersProto™ 40' Mather double-deck stock cars. The HO scale models feature factory-installed grab irons, a detailed



contents



index

underbody including all brake equipment, and 33" metal wheelsets. Available roads will be Baltimore & Ohio, CB&Q, GSX, and Northern Pacific as seen here. The ready-to-run models have an MSRP of \$34.98 each.



Walthers plans to release its 54' UTLX 23,000 gallon funnel flow tank car in six road names late this month. Features on the HO scale model include a newly-tooled etched-metal walkway and loading platform, separate grab irons, road-specific placement of manways and safety valves, complete train line and brake rigging, and 36" metal wheel sets. Decorating schemes include Cargill, CELX/Celtran, SHPX/Kerr-McGee, Procor, SUNX/Sunoco, and ADMX- Archer-Daniels-Midland as seen above. WalthersProto™ ready-to-run models have an MSRP of \$37.98 each.

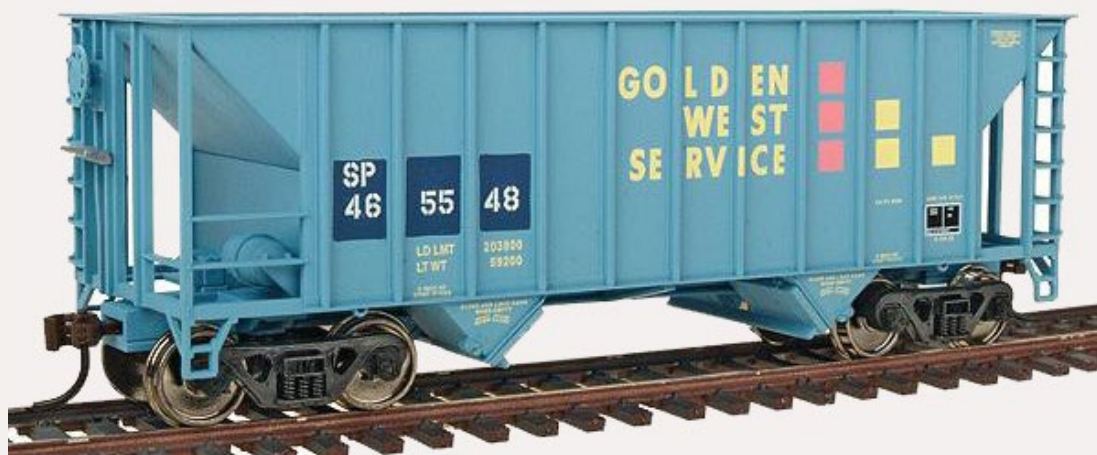

Walthers Mainline series hopper cars will be available late next month at an MSRP of \$24.98 each. The 34' 100-ton two-bay

cars will be decorated for Norfolk Southern (red oxide body), Southern (red oxide body), SP/UP (boxcar red with UP shield), and SP Golden West Service as seen above. The HO scale ready-to-run cars are weighted with a one-piece die-cast underframe.



Walthers has scheduled a second quarter release date for its Mainline series of 53' rebuilt Husky Stack well cars. The all-purpose well

car can handle 20', 40', 45', 48', and 53' containers. Road names will be TTX, FEC (yellow), FEC (mineral red), St. Mary's Railway West, and undecorated. The HO scale ready-to-run models will be available individually at an MSRP of \$24.98 and in 3-packs at \$69.98.

WrightTRAK Railroad Models LLC (wrighttrak.com) has acquired the HO scale product line of Smoky Mountain Model Works (SMMW). According to the announcement, all of the HO scale kits formerly sold by SMMW are now available from WrightTRAK. The list includes a Southern Railway Pullman-Standard gondola priced at \$44.95. The gondola is available in both the as-delivered railroad Roman lettering and the later block lettering style. Also currently available are two versions of the Tennessee Central boxcar built by Pullman-Standard in 1941 and humorously labeled by railroad historians as the PS-0. Both the as-built version and



contents



index



the 500-564 series cars refurbished in 1958 with reinforced door corners are available at \$49.95 each. A Seaboard Air Line class B6 boxcar is scheduled to be available later this month. Also under development is a Seaboard class V10 ventilated boxcar.

NEW PRODUCTS FOR N SCALE

American Model Builders (laserkit.com) is selling a laser-cut kit for an N scale Great Northern 25' wood caboose with a cupola. The kit is based on a modernized version of GN's wood crummies built prior to 1930. GN's upgrading program began in the 1950s and included installing additional windows, modifying the cupola, adding all-steel end platforms with railing and gates, adding square ladder safety extensions, new tool boxes, plus other updates to both the exterior and interior of the cars. Several of the prototypes saw service well into the era of the Burlington Northern.

The kit body uses tab & slot construction with sides, ends, cupola, underframe, and end platforms laser-cut from precision fine-grain plywood. Additional components include peel-n-stick window, door and trim assembly; ladders; end railing; hand grabs; window glazing; and brake wheels. Cast resin platform steps, brake gear, and a plastic smoke jack are



included. The instructions include information on painting and decaling the assembled model. This is a body kit only and does not include trucks, couplers or decals. AMB recommends Micro-Trains No.1015-1 universal body mount couplers, Atlas No. 22061 plain bearing caboose trucks, and Microscale decal sheet No. 60-757.



Atlas (atlasrr.com) will release its N scale Baldwin VO-1000 diesel locomotive with new road names during the second quarter of this year. New decorating schemes include Burlington Route, Frisco, and Union Pacific as seen here. New numbers for previously released road names include Baltimore & Ohio, Missouri Pacific, Southern Railway, and Terminal Railway of St. Louis. The



contents



index

Atlas Master® series ready-to-run model will be equipped with a NCE DCC decoder at an MSRP of \$144.95 each. An undecorated version is priced at \$109.95.



Also due from Atlas during the second quarter are new paint schemes on an American Car & Foundry 5300 cu ft 50' 6" boxcar. Spotting features of the ready-to-run model include non-terminating corrugated ends, diagonal panel roof, and a 10' Youngstown door. Road names are Atchison, Topeka & Santa Fe; Laurinburg & Southern; Missouri Pacific (with Texas & Pacific reporting marks); National Railway of Mexico; Ontario Northland; Terminal Railway Alabama State Docks; and Union Pacific (with Missouri Pacific reporting marks). The N scale model has an MSRP of \$15.95. An undecorated version will be offered at \$12.95 each.



Atlas will have new road names for its N scale two-bay, offset-side hopper car ready for delivery during the second quarter of this year. New schemes with removable coal load will

be Canadian Pacific; Elgin, Joliet & Eastern; Erie Lackawanna; Pittsburgh & West Virginia; Reading (above); Wheeling & Lake Erie; and Southern Railway. The cars list at \$18.95 each or \$53.85 for a 3-pack. An undecorated model will be available at \$16.95 each.

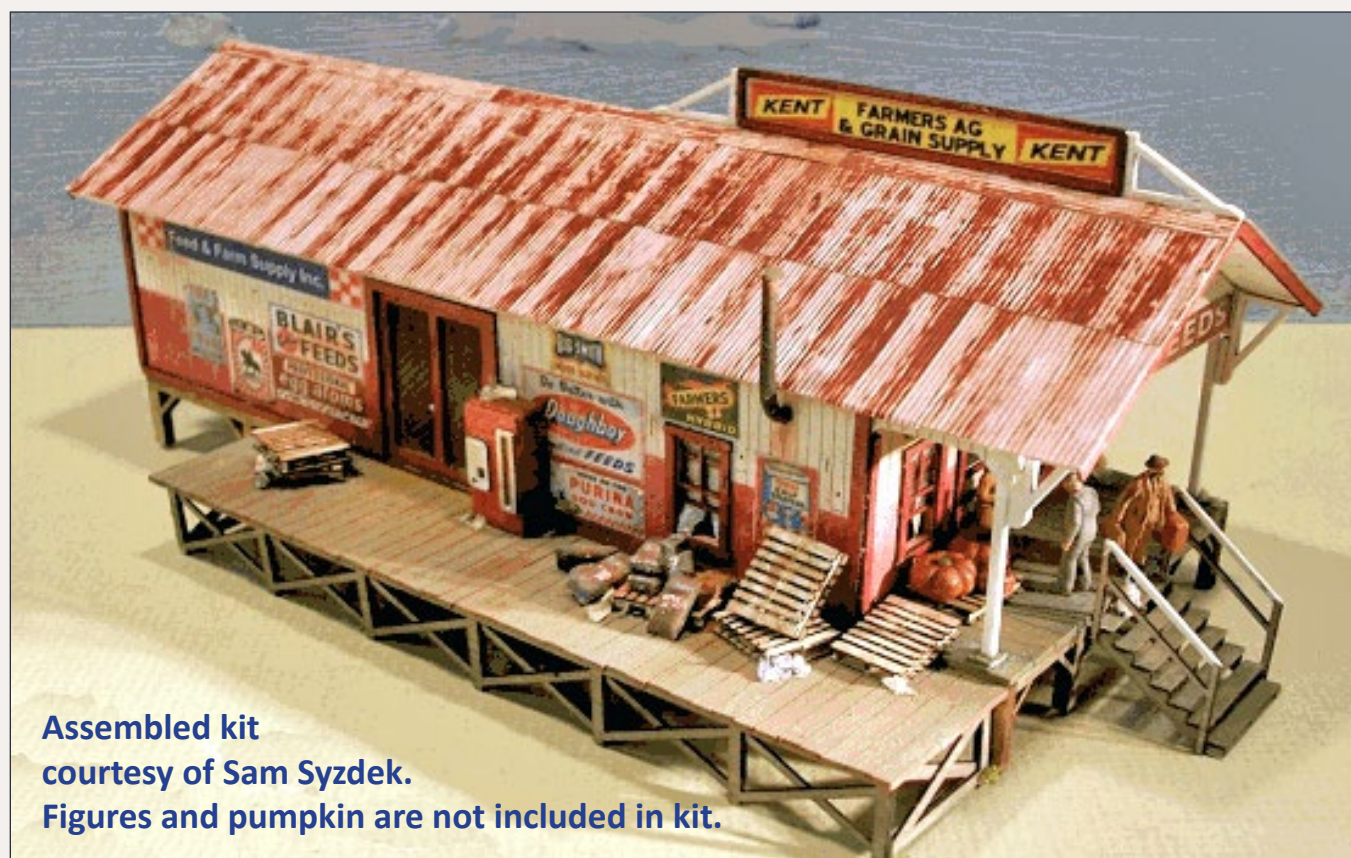

Assembled kit
courtesy of Sam Syzdek.
Figures and pumpkin are not included in kit.

Blair Line (blairline.com) is working on an N scale structure kit for Greene's Feed & Seed. The kit features tab and slot construction. The siding of the structure is composed of laser-cut planks with nail holes, knots, and other detailed imperfections. The doors, windows, and corner trim are laser-cut on peel-n-stick material. The windows are positionable. The corrugated roof material is pre-weathered. An assembly jig is provided for the laser-cut stair components. Pallets, eave brackets, feed sacks, and a soda pop machine are all laser-cut. Other details include a cast metal smoke jack and a variety of signs. The loading dock, which can be positioned on either side of the main building, features nail holes laser-etched in random length floor planks. The



contents



index

N scale kit is scheduled for release in mid-June at an MSRP of \$39.95. The structure has a footprint of 3.90" x 1.51". The dock measures 3.05" x .60".



Reservations close January 15, 2013, for **BLMA's** (blmamodels.com) new variation on its popular Norfolk Southern class G-85R TopGon coal cars. Cars in this fourth production release will feature a smooth tub underframe without the ribbed braces. The car will be available in 24 numbers with each road number displaying specific light and loaded weight data. The injection molded plastic cars will have separately applied wire grab irons and uncoupling levers, etched-metal brake wheel platforms, accurate internal bracing, Accumate® rucks and couplers. The N scale ready-to-run cars will have an MSRP of \$22.95 each. Delivery is planned for the fourth quarter of 2013.



InterMountain Railway Company (intermountain-railway.com) plans to release the next run of N scale four-bay cylindrical covered

hoppers in March. The ready-to-run models will come with Micro-Trains® trucks and couplers. Models with round roof

hatches have an MSRP of \$21.95 and will be available in six numbers each for Canadian National (environmental mode, wet noodle), Canadian National (grey body, red wet noodle), Canadian National (grey body, black wet noodle), Canadian National–Continent, Potash, CP–Multi Mode, UNPX–Alcan Chemical Products (above), and Roberval Saguenay.



Models with a trough hatch have an MSRP of \$22.95 and will be available in six numbers each for CNWX–Canada (red), CPWX–Canada (red), FLIX–Farmland Coop (above), CNWX–Canadian Wheat Board, CPWX–Canadian Wheat Board, CNIS–Canadian National (grey body, red wet noodle), and Ferrocarril Del Pacifico.

Kato USA (katousa.com) has announced two new N scale models in its Kobo Custom line: a Pennsylvania Railroad GG-1, and a BNSF business car. Both models are scheduled for availability late next month. The GG-1 is based on Pennsylvania's Congressional trains that operated between New York City and Washington D.C. during the 1950s. Three of the six GG-1s Pennsy assigned to the train were decorated in a special variation of the Congressional Silver scheme with a broad red stripe and a large keystone shadow herald. Kato's GG-1 has an MSRP of \$195.00.



contents



index



The silver business car is decorated for BNSF #1. It was built by Budd in 1952 for the then-president of the CB&Q Harry Murphy. The car has had several names including CB&Q "Burlington" and BN's "Mississippi River." Today it has been refitted and relabeled with BNSF's new "Swoosh" logo and the name of former BN CEO Gerald Grinstein who was part of the merging of the BN and ATSF into the BNSF. Features include dome roof antennas and new name plates above the cars corrugated sides. Kato's BNSF business car #1 has an MSRP of \$80.00.

Kato has introduced an N scale container picker. The North American style vehicle features an adjustable lift crane that can hold Kato's 40' and 53' containers at both raised and lowered positions.



For stability the picker has a heavy die-cast base. It is available in either red or yellow at an MSRP of \$25.00 each.

Later this month Kato is scheduled to begin selling individual models of its N scale

GE P42 Genesis Phase Vb locomotives. Previous releases were packaged with train sets. The P42 will be offered in two road numbers (#61 and #80) for DC operation at \$125.00 each, or with factory installed DCC at \$165.00 each.



Micro-Trains Line Co. (micro-trains.com) is selling a limited run of Montana Rail Link 3-bay covered hopper cars in a 4-pack at \$137.95. The prototype of the 4427 cu ft grain hopper was built by Pullman-Standard.



Micro-Trains has released this 40' double-sheathed

wood-side reefer decorated for OREX-Boote's Hatcheries. The ready-to-run N scale car is priced at \$26.95.



contents



index



This 39' single dome AC&F tank car decorated for Canadian Pacific is available from Micro-Trains at \$21.69.



Micro-Trains is selling an 8-pack of Norfolk & Western two-bay open-top hopper cars with peaked ends at \$149.95.



This 40' PFE N scale trailer is available now from Micro-Trains at \$27.20 each.



Gasoline Alley is **Sidetrack Laser's** (sidetracklaser.com) newest addition to its gas station series of N scale structure kits. The new model is based on a gas station that operated several years ago in Banks, Oregon. The N scale kit is composed of laser-cut structural components, a shake-shingle roof, Grandt Line windows, cast detail parts, and a selection of paper signs. As pictured above (vehicles are not included), the finished model has a footprint of 2.5" x 5". Gasoline Alley has an MSRP of \$37.95.

Trainworx (train-worx.com) plans to deliver another series of 100-ton quad hopper cars this summer. The ready-to-run cars will have Fox Valley metal wheel sets and body-mounted magnetic couplers. Road names and decorating schemes on this release include CSX (bold orange lettering), CSX (white re-stencil on black patch), Southern (black body), Southern (oxide red body), Union Pacific (class H100-18 with yellow end), and Union Pacific (three color shield, yellow end). The cars have an MSRP of \$24.95 each.

Woodland Scenics (woodland-scenics.woodlandscenics.com) is selling an assembled N scale traditional wood barn with a gambrel-roof and a silo. The pre-assembled, pre-weathered structure features a field stone foundation, shake-shingle



contents



index



roof, hayloft door with pulley and rope, a vintage weather vane on a slatted cupola, concrete silo, and a lean-to shed. Additional details include aging barn doors and multi-paned windows. The structure has an MSRP of \$69.99 each.

NEW PRODUCTS FOR Z SCALE

Micro-Trains Line (micro-trains.com) is selling an 8-pack of Z scale two-bay open top hopper cars decorated for Norfolk & Western. The 8-pack is priced at \$129.95. See N scale report for illustration.

NEW DECALS, SIGNS AND FINISHING PRODUCTS

Dr Bens (debenllc.com) has driftwood weathering stains that are reported to be comparable to Floquil products. The stains are available in 8 ounce jars at \$11.99 each. Colors currently

available include Orbisonia Green, Pacific Redwood, Black Mahogany, Depot Olive Green, Antique White, Country Hickory, Rail Brown, Hardwood Maple, Rustic Oak, Durty Black, Knotty Walnut, Rustic Barn Red, Natural Basswood, Nautical Teak, and Natural Pine. Each of the colors can be viewed in various stages of intensity at the above website.



Microscale Industries

(microscale.com) has new decals for Western Pacific 50' and 60' boxcars from the early 1980s. Also newly released are decals for Burlington Northern boxcars, open hoppers, and gondolas from the 1970-1989 period. The set includes appropriate freight car data. Cotton Belt (SSW) lettering sets that include heralds have been released for 40' and 50' freight cars. The WP, BN, and Cotton Belt sets are priced

at \$7.00 for HO and \$5.75 for N scale. Basic data sheets for Pullman Standard covered hoppers are available now at \$5.75 and \$4.50 for HO and N scale respectively. Sets are available in either black or white lettering. Decals currently under development at Microscale include miscellaneous data for modern tank cars, RailGon and HERZOG gondolas, and new image Ontario Northland hood diesels including GPs and the SD75i.



contents



index

Dan Kohlberg Decals (home.mindspring.com/~paducah/icg62.htm) has introduced HO scale lettering sets for Illinois Central Gulf GSC flat cars that were redecorated following the IC and GM&O merger. The merger involved more than 1000 General Steel Casting flat cars of various classes. The Kohlberg set has enough material to letter four different cars and includes a decaling diagram for five classes of ICG cars.

Mount Vernon Shops (mountvernonshops.com) is selling HO scale decals for Pennsylvania Railroad class F22 and F23 flat cars. Each set includes enough data to decorate two F22 and two F23 cars. Accurate HO scale models of the class F22 flats have been offered in brass by Railworks, and both the F22 and F23 are available as resin kits from Funaro & Camerlengo. In addition to data for lettering the cars, decals are included for the large Load Bridges available from American Model Builders. The loads were numbered to match the cars they were assigned to.

DISCLAIMER

The opinions expressed in this column are those of the writers and do not necessarily reflect the opinion of *Model Railroad Hobbyist* or its sponsors. Every effort is made to provide our readers with accurate and responsible news and information, however, neither *Model Railroad Hobbyist* or the writers of this column can be held responsible for any inaccuracies or typographical errors that may inadvertently appear in this column.

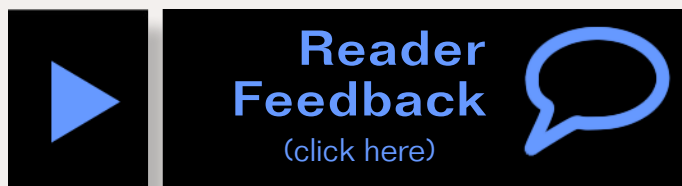



Send us your product announcements

If you are a hobby manufacturer with a product announcement, just [click here](#) and submit your announcement to us. Our web site and free magazine reach continues to grow, so get on board with this new media train that's hard to stop!

Briefly noted at press time...

... Look for **Athearn division of Horizon Hobby** (athearn.com) to introduce at least three new locomotives this year. The identity of the first will be revealed at the Amherst Railroad Hobby Show to be held later this month in West Springfield, Massachusetts.

... **Imperial Hobby Production** of Wynnewood, Pennsylvania (ihphobby.tripod.com) has completed tooling for a plastic injection molded single-ended Kawasaki LRV decorated for Southeastern Pennsylvania Transportation Authority (SEPTA). Although the non-powered HO scale model is being developed for sale through SEPTA's Gift Store, it seems likely that IHP will eventually offer a power conversion kit for the static display model. We'll have additional details, including pre-production photos, next month.

... **Atlas O** (atlaso.com) will release its O scale ACF 8,000 gallon type 27 riveted tank car with new decorating schemes sometime during the third quarter of this year. Road names will be Shipper's Car Line, Champlin Refining, Colorado Animal By-Products, Lion Oils, Omar Refining, and Shell Chemical. The 3-rail version of the ready-to-run model will have an MSRP of \$69.95, with the 2-rail edition listing at \$74.95. ■



contents



index

Some of the finest
trees in the hobby ...

... available
in any scale!

CANYON CREEK
SCENICS

canyoncreekscenics.com



click to visit our web site



Selected Events



January 2013

CALIFORNIA, SANTA CLARA, January 24-26, O Scale West and S West Annual Meet. Hyatt Regency Hotel, 5101 Great American Parkway. Info at oscalewest.com.

FLORIDA, COCOA BEACH, January 10-12, Prototype Rails/Cocoa Beach 2013. Major RPM meet hosted annually by Mike Brock. Blue ribbon panel of clinicians includes Frank Angstead, Al Brown, Jon Cagle, Jeff Cauthen, Bill Darnaby, Chuck Davis, James Dick, George Eichelberger, Steve Funaro, John Greedy, Michael Gross, Robert Gross, Jared Harper, Richard Hendrickson, Roger Hinman, Charles Hostetler, Larry Kline, Tony Koester, Gail Komar, Tom Langston III, Greg Martin, Lance Mindheim, Jim Murie, Joe Oates, Steve Orth, Frank Peacock, Cynthia and Stephen Priest, Mike Rose, Tom Salmon, Bill Schaumburg, Bill Schneider, Jim Singer, Bruce Smith, Andy Sperandeo, Perry Sugerman, Mont Switzer, Ken Tendick II, Gilbert Thomas Jr., Tony Thompson, Mark Vaughan, Bill Welch, O. Fenton Wells, John Wilkes, Tom Wilson, and Craig Zeni. Friends of the Freight Car lunch at noon on Saturday. Hilton Hotel, 1550 N. Atlantic Ave. (Highway A1). For hotel reservations call 800-526-2609 or 321-799-0003. Refer to Prototype Rails for reduced rate. For event information visit prototyperrails.com or contact Mike Brock at brockm@cfl.rr.com.

MARYLAND, BALTIMORE, January 6, 13, 20, 27, 80th Annual Holiday Open House sponsored by BSME – Baltimore Society of Model Engineers. Featuring two large layouts (O and HO scales) with operating steam and diesel powered trains plus trolleys.



contents



index

Open 1 to 5 pm at 225 West Saratoga Street (3rd floor walkup). Admission by donation. Additional info at modelengineers.com.

MASSACHUSETTS, WEST SPRINGFIELD, January 26-27, Amherst Railroad Hobby Show, sponsored by Amherst Railway Society. Major event attracting 25,000 or more people annually with operating layouts, clinics, and up to 250 vendor tables. Participants include manufacturers, publishers, importers, and historical societies. Eastern States Exposition Fairgrounds. Info at railroadhobby-show.com/abouttheshow.php.

MISSOURI, ST. LOUIS, January 12-13, The World's Greatest Hobby on Tour with dozens of manufacturers displays, demonstrations, and operating equipment. Sponsored the Model Railroad division of the Hobby Manufacturer's Association, the traveling event is designed to introduce the general public to model railroading in an entertaining, lively and family-friendly atmosphere. America's Center, 701 Convention Plaza, 63101. Info at wghshow.com.

PENNSYLVANIA, FORT WASHINGTON, January 5-6, 19-20, and February 9-10. Final Open House of 38-year old GATSME (GATSME), an historically driven organization that has built an outstanding HO scale operating layout in the Old Fort Washington Elementary School. The club has lost its lease and the layout will be torn down after the final operating session on February 10, 2013. Visit gatsme.org for additional information including history of the club and the old school building.

PENNSYLVANIA, YORK, January 5-6, Annual Open House, hosted by Miniature Railroad Club of York, Saturdays 3 to 8 PM, Sundays 1 to 5 PM. Event at 381Wheatfield Street. Donation at door. Info at mrrcy.com or call (717) 458-2932.

TEXAS, FORT WORTH, January 5-6, The World's Greatest Hobby on Tour with dozens of manufacturers displays, demonstrations, and operating equipment. Sponsored the Model Railroad division of the Hobby Manufacturer's Association, the traveling event is designed to introduce the general public to model railroading in an entertaining, lively and family-friendly atmosphere. Will Rogers Memorial Center, 3401 W Lancaster, 76107. Info at wghshow.com.

WEST VIRGINIA, HARPERS FERRY, January 19, Steve Sherrill Open House with modular layouts including On30 SG&S Railroad, dead rail demonstrations, vendor tables, and narrow gauge camaraderie. First Baptist Church, 614 Lone Oak Road, Ranson 25438. Info from Steve Sherrill at 304-725-4797.

February 2013

CALIFORNIA, SACRAMENTO, February 23-24, The World's Greatest Hobby on Tour with dozens of manufacturers displays, demonstrations, and operating equipment. Sponsored by the Model Railroad division of the Hobby Manufacturer's Association, the traveling event is designed to introduce the general public to model railroading in an entertaining, lively and family-friendly atmosphere. California Exposition & State Fair (CAL-EXPO), 1600 Exposition Blvd, 95852. Info at wghshow.com.

CALIFORNIA, SAN DIEGO, February 9-10, The World's Greatest Hobby on Tour with dozens of manufacturers displays, demonstrations, and operating equipment. Sponsored by the Model Railroad division of the Hobby Manufacturer's Association, the traveling event is designed to introduce the general public to model railroading in an entertaining, lively and family-friendly atmosphere. Del Mar Fairgrounds, 2260 Jimmy Durante Blvd, Del Mar, CA 92014. Info at wghshow.com.



contents



index

GEORGIA, PINE MOUNTAIN, February 1-3, Southern Rails (formerly Narrow Gauge Railway Day). Family oriented event with clinics, contests, vendors and 'down south' fun, at Callaway Gardens. Info at southernrails.org.

MARYLAND, TIMONIUM, February 2-3, Great Scale Model Train Show. One of the nation's largest shows with more than 800 vendor tables. Hosted by Howard Zane at Cow Palace, Maryland State Fairgrounds. Information at gsmts.com.

NEW YORK, STATEN ISLAND, February 2-3, Winter Meet, sponsored by NMRA Garden State Div, Northeastern Region. At St. Margaret Mary's Presentation Hall, 1126 Olympia Blvd. Subject to reschedule due to Hurricane Sandy. Visit nergsd.com for latest info.

TEXAS, HOUSTON, February 16, Greater Houston Train Show, features 20,000 sq ft of operating layouts, instructive classes, model and photo contests, train videos, and vendors. Also tours of local home layouts. At Stafford Center, 10505 Cash Road at Murphy Road. Hosted by San Jacinto Model Railroad Club. Info at sanjac.leoslair.com/resources/2013-Public-Flyer.pdf.

WEST VIRGINIA, CHARLESTON, February 9-10, 8th Annual Train Show, sponsored by Kanawha Valley Railroad Association, at Clubhouse in Coonskin Park. Details available from Joe at (304) 539-6721, or email at horter@suddenlink.net.

Future

AUSTRALIA, MELBOURNE, March 29-31, 2013, 11th Annual Australian Narrow Gauge Convention, at Carwatha College, Noble Park North. Info at cngg.org.au/ozngc2013.

AUSTRALIA, MELBOURNE, April 12-14, 2013, 13th National Australian N Scale Convention, at Rydges Bell City Event Centre, Preston. Info at convention2013.nscale.org.au or send email to nscale2013@bigpond.com.



CANADA, ALBERTA, CALGARY, April 20-21, 2013, Supertrain, with live demo, clinics, and manufacturers displays. Subway Soccer Centre, 7000-48 Street SE. For fees and hours visit supertrain.ca.

CANADA, ONTARIO, MISSISSAUGA, April 26-28, 2013, Streetsville Junction, NFR-NMRA Regional Convention featuring clinics, self-guided layout tours, and special Canadian manufactures show Friday evening. Clinicians include Chris Lyon, Graham Macdonald, Pierre Oliver, Dave Patterson, John Spring, and Paul Taylor. Awards Sunday morning at Hobo breakfast. Info at streetsvillejunction.com. Eventa at Four Points Sheraton Hotel, 2501 Argentia Road. Call 905-858-2424 for hotel reservations.

CANADA, ONTARIO, TORONTO, March 16, 2013, Annual Railway Prototype Modellers Meet, with clinics on auto frame cars, detailing prototype trackwork, and realistic freight car weathering. Also show and tell program and an open discussion forum on prototype modeling. Attendees are urged to bring a model(s). 9 am to 2:30 pm at Humber College, North Campus, Building B, rooms B201& B202. Admission is \$10, parking is free. For info contact Brian Gauer at: bdgauer@rogers.com.

CALIFORNIA, BAKERSFIELD, March 9-10, 2013, Annual Model Train Show & Swap Meet, with 100 dealer tables, operating model train displays, and hourly prizes. Sponsored by Golden Empire Historical & Modeling Society Model Train Club. At Kern County Fairgrounds, 1142 South 'P' Street. Hours and fee info at gehams.net.

CALIFORNIA, PASADENA, August 28-31, 2013, 33rd National Narrow Gauge Convention. Hilton Hotel, 199 S. Los Robles St. Info at 33rdnngc.com. Volunteer clinicians please contact Carl Heimberger at clinics@33rdnngc.com.

CALIFORNIA, SAN MATEO, March 2-3, 2013, The World's Greatest Hobby on Tour with dozens of manufacturers displays, demonstrations, and operating equipment. Sponsored by the Model Railroad division of the Hobby Manufacturer's Association, the traveling



contents



index

event is to introduce the general public to model railroading in an entertaining, lively and family-friendly atmosphere. San Mateo County Event Center, 1346 Saratoga Drive. Info at wghshow.com.

COLORADO, LONGMONT, December 8-9, 2013, Annual Train Show, sponsored by Boulder Model Railroad Club, with operating layouts, prize winning models, vendor tables, and a layout raffle, plus a chance to meet and chat with area railroad modelers. Boulder County Fairgrounds. Info at bouldermodelrailroadclub.org.

GEORGIA, ATLANTA, July 14-20, 2013, National Model Railroad Annual Convention. At Cobb Galleria Centre with convention HQ at adjacent Renaissance Waverly Hotel. Info at nmra2013.org.

GEORGIA, ATLANTA, July 18-20, 2013, National Train Show, in conjunction with annual NMRA convention. At Cobb Galleria Centre, 2 Galleria Parkway. Info at nmra2013.org.

GEORGIA, PORT WENTWORTH (Savannah area), April 4-6, 2013, 13th Annual Savannah RPM at Port Wentworth Community Center located on Appleby Road. Program follows RPM format with clinics, model displays, vendors, historical societies, and brotherhood. Information from Bob Harpe at Rharpe@comcast.net or Denis Blake at dblake7@columbus.rr.com. Send \$20.00 for weekend registration to Robert Harpe, 313 Paradise Drive, Savannah, GA 31406.

ILLINOIS, LOMBARD, March 15-17, 2013, Chicago O Scale Meet, at Westin Lombard Yorktown Center. Info at marchmeet.net.

INDIANA, INDIANAPOLIS, May 2-5, 2013, Mile Post 50, annual convention of NMRA Central Indiana Division, with layout tours, operating layouts, op sessions, clinics, and contests. Banquet speaker is Thomas Hoback, president/CEO of Indiana Railroad Company. Marriott Indianapolis East, 7202 East 21st Street. Phone

317-352-1231 for reservations. Additional information including registration form available at cid.railfan.net.

MARYLAND, TIMONIUM, April 13-14, 2013, Great Scale Model Train Show. One of the nation's largest shows with more than 800 vendor tables. Hosted by Howard Zane at Cow Palace, Maryland State Fairgrounds. Information at gsmts.com.

MASSACHUSETTS, PEABODY, March 9, 2013, Annual Spring TRAINing Show, sponsored by NMRA Hub Division, Northeastern Region, with operating trains, vendor tables, and clinics ranging from fundamental to advanced including special clinic by Paul Dolkos. Holiday Inn, 1 Newbury Street. Info at hubdiv.org.

MICHIGAN, MOUNT PLEASANT, March 24, 2013, 33rd Annual Mid-Michigan Model Train Show, with operating layouts, door prizes and more than 200 vendor tables. Proceeds to Clare Depot Preservation, Inc. & Dog Tales, Inc. At Finch Fieldhouse, Central Michigan University. Free parking. Info from John Thompson at redwings48618@yahoo.com or call 989-465-6459, or Dan Foltz at MidMichiganModelTrainShow@gmail.com.

MINNESOTA, BLOOMINGTON, April 25-28, 2013, 28th Annual Sn3 Symposium. Ramada Mall of America Hotel. Info at Sn3-2013.com.

NEW MEXICO, ALBUQUERQUE, June 6-9, 2013, Rails Along the Rio Grande, NMRA Rocky Mountain Region, Rio Grande Division 6, convention with clinics, layout tours, train show, OpSig sessions, UPRR and BNSF modelers showcase night, and banquet. Marriott Pyramid North. Info at rarg2013.org.

OHIO, KIRTLAND, March 16-17, Railfest 2013, sponsored by NMRA MCR Division 5. Ohio's largest two-day train show. Lakeland Community College near SR306 and I-90. Info at railfest.org.

OHIO, MIAMISBURG (Dayton area), May 15-18, 2013, Operation Dayton 2013, NMRA-MCR convention with clinics,



contents



index

model contests, layout tours, railfanning, and more. Wyndham Gardens Hotel. Info at MCR2013convention.com.

OREGON, PORTLAND, March 9, 2013, Willamette Model Railroad Club Swap Meet, featuring more than 110 vendor tables of model railroad equipment, railroad memorabilia, books, photos, and more. 10 am to 3 pm at Kliever Memorial Armory, 10000 NE 33rd Drive. Free parking. For info contact wmrswapmeet@yahoo.com.

WISCONSIN, WEST ALLIS (Milwaukee area), November 9-10, 2013. Trainfest 2013, sponsored by Wisconsin Southeastern Division of NMRA. ■

Advertisement

HO, N, Z AND O-SCALE PREMIUM LASER STRUCTURES

RSM precision cut laser structures offer a level of realism rarely seen in Model Railroad structures.

Learn why we're different



THE GRASSELLI TOWER

The Grasselli Tower guards the junction between the IHB, EJ&E, and B&OCT in East Chicago, Indiana.

\$59.95 RSM #201001 Z Scale Laser Cut Grasselli Tower

\$94.95 RSM #451001 O Scale Laser Cut Grasselli Tower

\$69.95

RSM #871001 HO Scale Laser Cut Grasselli Tower

RSM #601001 N Scale Laser Cut Grasselli Tower

THE CASTLE CAR WASH

The "Castle" Car Wash is a famous Route 66 landmark in Chicago, Illinois.

\$69.95

RSM #871002 HO Scale Laser Cut Castle Car Wash

RSM #601002 N Scale Laser Cut Castle Car Wash

\$59.95 RSM #201002 Z Scale Laser Cut Castle Car Wash

\$94.95 RSM #451002 O Scale Laser Cut Castle Car Wash

Dealer Pricing Available



Toll Free
1-888-762-6872

122 N. Main Street
Elburn, IL. 60119

reynalds.com/rsm.aspx
info@reynalds.com

[facebook.com/ReynaldsEuroImports](https://www.facebook.com/ReynaldsEuroImports)

Click to
visit us

REYNAULD'S
FULL STEAM AHEAD SINCE 1904
EURO IMPORTS, INC.





con-cor.com
888-255-7826

Super Sale
on HO & N Items
Up to 75% Off



Choose from
more than
200 items!

www.con-cor.com/sitemap.htm



**Powered &
Non-Powered**

**Click to see the
online video**

www.con-cor.com/HO-Powered-mP54.html

HO & N Passenger Cars



Start at our Site Map to see the Variety Available.
www.con-cor.com/AdPortal22.html

HO New Haven Comet

Optional Sound Available \$459.98 3-car set



In Stock Now!

Video online!!

www.con-cor.com/Comet.html



HO 1935 Reading Crusader Set

- Steam Loco + 5 Car Set
- Pre-Order Save 20%
- Optional Sound

Set of 5 cars only, (no stream loco) will also be available for diesel era Reading fans.

www.con-cor.com/Partners/GHB.html



Model Railroad Hobbyist magazine™

YES, subscribing MATTERS!

(even though it's free)

**It helps MRH get more
advertisers**

Click here to subscribe!

Newbies: Start with the train

Reverse Running: Stepping outside the box with a contrary view

by Ken Sipel

In the \$500 hobby newcomer contest, what's the best design for getting started? A power supply and DCC controller, some track, one engine with a decoder, and a piece of plywood – that's what!

For newcomers, I'm a firm believer in keeping the choices simple: what engine do you like? Let's start there.

In the early days, things need to get moving quick or frustration ensues. For starters, a loop of track is best because it's nice to see that new engine run.

Right about now you're thinking, "What kind of train is that? It's just an engine!"

At this early stage our newbie has spent all his money, and what did he get for it? He has something of decent quality with DCC that runs and he's now a model railroader! He's learning the true basics of the hobby and most importantly: he's hungry for more.

Those of us more seasoned in the hobby know how multifaceted it is: from building models to electronics to making scenery. "But the newbie hasn't done any of this yet," you say.

You're right, sort of. I find half the hobby is mental. There's dreaming, which turns into research, then into planning, then

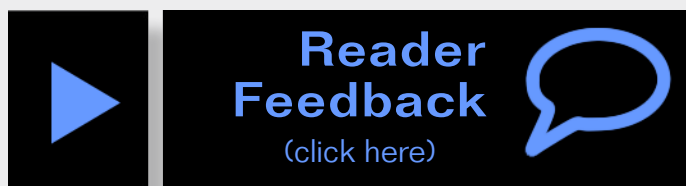
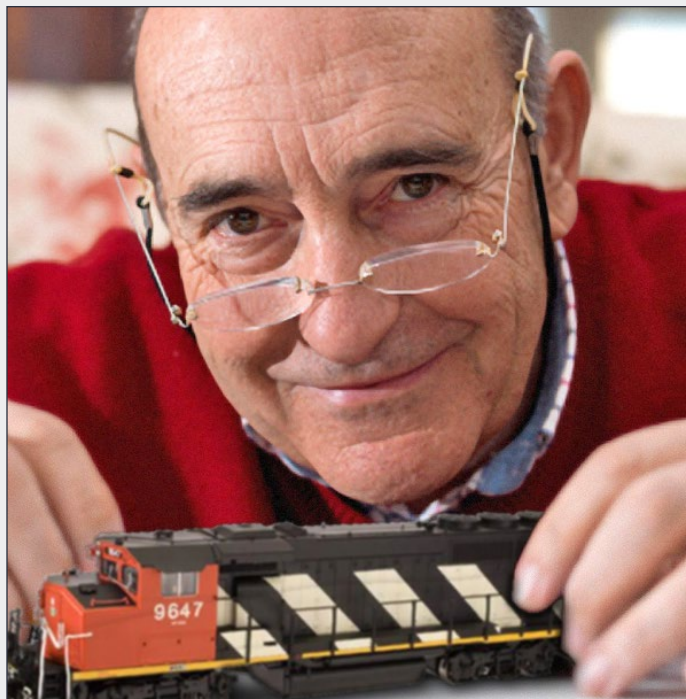

drawing, and finally more dreaming. That's why I handicapped our newbie with just an engine and some track. He needs time to digest the hobby and grow into doing it.

Next we set our newbie on a quest to find out about the engine he bought. When was the prototype made, where did it run, and what did it do? What number is on that engine? Who owned this particular engine? Lots to learn, just about a single engine!

We give him a new quest: find a club or a layout to visit and run trains. This shows him the hobby in full flower, and also provides a full-blown example he can get his hands on. All the while, he's asking questions and learning answers.

He's using all his track now and has been talking with other modelers, so he's created a more complex track arrangement. The track is still just sitting on plywood, so we can show him some articles that take a single sheet of plywood and make a more finished layout. He's intrigued, but still likes going round and round in between switching a spur he has added.

Someone asks him what he models. He says he's into the road on the side of the loco he bought. But now we've got him thinking more about what goes into making a layout. And we've done it naturally, without overwhelming him.

Our new modeler got a good start with good quality equipment (not some cheap train set), and he is able to grow and expand his hobby involvement now with real purpose.

Item	Cost	Source
NCE Powercab	\$ 155.96	Litchfield Station
Kato HO unitrack WGH plan set	\$ 162.98	Amazon.com
Athearn GP40-2 with decoder	\$ 98.98	Tony's Train Exchange
1/2" sanded sheet 4x8 plywood	\$ 34.97	Home Depot
Total:	\$ 452.89	



contents



index

Clickable advertiser index

[Accu-Lites](#)

[Accurail](#)

[Alpine Division Scale Models](#)

[Amherst Railway Society](#)

[Backdrop Junction](#)

[BLMA](#)

[Bowser](#)

[Bullfrog Snot](#)

[Canyon Creek Scenics](#)

[Clever Models](#)

[Coastmans Scenic](#)

[Con-Cor](#)

[Dallas Model Works](#)

[Digitrax \(2 page spread\)](#)

[ESU](#)

[ExactRail](#)

[Fifer Hobby Supply](#)

[Great Decals](#)

[Horizon Hobbies](#)

[Iwata-Medea](#)

[Jelsma](#)

[Litchfield Station](#)

[Logic Rail Technologies](#)

[Microscale](#)

[Minimalist Model Railroading](#)

[Model Railroad Benchwork](#)

[Model Trains Video](#)

[Monster Modelworks](#)

[M.T.H.](#)

[Nano-Oil](#)

[NCE](#)

[North American Rail Car](#)

[O Scale Resource](#)

[Proto:87 Store \(1\)](#)

[Proto:87 Store \(2\)](#)

[RailMaster Hobbies](#)

[Railroad Explorer \(1\)](#)

[Railroad Explorer \(2\)](#)

[Rapido](#)

[Reynald's Euro Imports](#)

[Ring Engineering \(1\)](#)

[Ring Engineering \(2\)](#)

[RSlaser](#)

[Rusty Stumps](#)

[San Juan Car Company](#)

[SBS4DCC](#)

[Scenic Express](#)

[Southern Digital](#)

[Stans Trains](#)

[TAM Valley Depot](#)

[The Curio and Whatnot Shop](#)

[Tony's Trains \(2 page spread\)](#)

[TrainTek](#)

[True Line Trains](#)

[True Scene Modeling](#)

[Westerfield Models](#)

[Yankee Dabbler](#)



Clickable topic index

[DCC Impulses – DCC Sound](#)

[Editorial – Publisher’s Editorial](#)

[Editorial – Reverse Running](#)

[Getting Real – Mainline South, Continued](#)

[Layout – The Fort Wayne Union Railway](#)

[Layout Design – Determine the Best Size for Your Layout](#)

[News – January Newsletter](#)

[News – January Events](#)

[Product Show Case](#)

[Q and A – MRH Questions, Answers, and Tips](#)

[The Tool Shed – A Better Jeweler's Saw](#)

[Yes It's a Model – MRH Monthly Photo Album](#)

[What’s Neat This Week – Freight Cars of Jeff Meyer](#)

[Other – Bonus Extras](#)

[Other – Cover](#)

[Other – Derailments](#)

[Other – Hobby Marketplace](#)

[Other – Index](#)

[Other – MRH Sponsors](#)

[Other – Staff Notes](#)

[Other – Table of Contents](#)

Deraillments

humor (allegedly)



Things you should never model #3982: Uphill coal-fired mallet smoke

If you're the first to [submit a bit of good humor](#) and we use it, it's worth \$25!



**Reader
Feedback**
(click here)



For the love of model trains

Coming in February

- MRH visits the Columbia, Cascade and Western layout
- Master Modeler's workshop, in-depth
- Aisle lift-out bridge
- Kitbash a Conrail caboose
- Another \$500 starter layout contest winner
- ...and lots more!

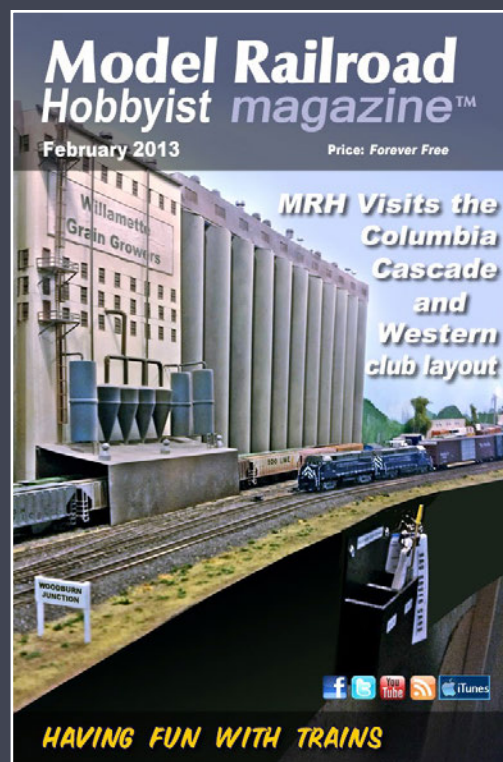

A man who spent his whole life on a desert island visited a friend in civilization. He'd never seen a train or railroad tracks.

While standing on the the railroad tracks, he heard a whistle, but didn't know what it was soon enough to avoid getting hit. His friend found him on the side of the tracks with minor internal injuries and broken bones.

After weeks in the hospital recovering, he visits his friend who is having a party. While in the kitchen, he suddenly hears the teakettle whistling. He grabs a baseball bat from a nearby closet and batters the teakettle into an unrecognizable lump of metal.

Upon hearing the ruckus, his friend rushed into the kitchen and asked the desert island man, "Why'd you ruin my good tea kettle?"

"You need to kill these things while they're still small!" he said.

Coming next issue



contents



index